

Product Information Packet

January 13, 2017

Data shown is for the current revision model #. Ensure your nameplate model # matches.

Model Number:	5KS213DAE5031B
Catalog Number:	V4201
Instruction Manual:	GEK-95353
Connection Diagram:	GEM2034E-FIG3
Outline Drawing:	4002B5821NMP5210

Accessory Connection Diagrams

Bearing Thermocouple:	None	Heater:	3027JE-1C
RTD:	None	Thermistor:	None
Thermostat:	None	Winding Thermocouple:	None
Bearing RTD:	None		

Table of Contents

Specification	01
Performance Characteristics	02
Outline Drawing	03
Connection Drawing(s)	04
Spare parts	05



Marks:

MODEL NUMBER:	5KS213DAE5031B	Estimated Weight:	172 Lbs
Outline Drawing:	4002B5821NMP5210	Time Rating:	CONT
Connection Diagram:	GEM2034E-FIG3	Enclosure:	WPI
Instruction Book:	GEK-95353	Encl Construction:	OPEN
Design Code:	21BD0117A	Ambient Max(°C):	40
Type:	KS	Alt Ambient Max(°C):	--
Frame:	L213TP10	Insulation Class:	H
Phases:	3	NEMA Design:	B
Poles:	2	Nominal Efficiency:	86.5 %
Output Power:	5HP 3.7KW	Guaranteed Efficiency:	84.0
RPM:	3550	3/4 Load Efficiency:	90.3
Voltage:	230/460	KVA Code:	J
Hertz:	60	Max KVAR:	1.4
Amps - FL:	12.2/6.1	Power Factor:	88.5
Service Factor:	1.15	Bearing - DE:	7308
Alt Service Factor:	--	Bearing - ODE:	6208-2ZC3

Enclosure is Weather Protected One

Stamped Nameplate Notes:

PREMIUM EFFICIENT MOTOR
 NEMA ENCL WPI AND CSA ENCL DP
 ROT CCW FACING ODE LEAD/PH SEQUENCE 1-2-3/1-2-3
 HTR LDS HE1-HE2 115V 60W
 INVERTER DUTY PER NEMA MG1 PART 31
 ALTERNATE RATING FOR PWM CONTROL:
 1.0 SF VAR TORQUE RANGE 10-60 HZ
 SUITABLE FOR 3HP, 190/380V,
 50 HZ WITH 9.2/4.6AMPS AND 2930 RPM AT 1.0 SF

Additional Information:

2P - TP EXTN
 C/BOX 55 CU IN-1.00 NPT
 AUX LEADS EXIT WITH MOTOR LEADS
 RCF 5000 CPM, STATIC DEFLECTION .0014 INCHES &
 CENTER OF GRAVITY 8.59 INCHES
 HOLLOW SHAFT HIGH THRUST
 OIL RESISTANT SLEEVING ON LEADS
 BEARING LIFE 5788 HOURS AT 1900 LB THRUST
 BEARING LIFE 8760 HOURS AT 1650 LB THRUST
 BALL TYPE COUPLING
 COUPLING WILL BE ORDERED SEPARATELY

Performance Characteristics

1st Winding 1st Connection

Design: 21BD0117A

Marks:

LOAD %	125.0	115.0	100.0	75.0	50.0	25.0	0.0
% EFF	89.86	90.12	90.58	90.25	88.75	82.59	0.00
% PF	89.54	89.2	88.31	85.2	77.68	58.17	11.62
AMPS	7.27	6.69	5.84	4.56	3.39	2.44	1.9

TORQ(FL)#FT	7.4	TORQ(LR)%FL	211.52	TORQ(BD)%FL	326.38
AMPS(LR)	42.26	PF AT START	0.34		

This motor is capable of two cold or one hot start with a maximum connected load inertia of 80 Lb-Ft Sq (3.37 Kg-meter Sq)at 100% voltage, where the load torque varies with the square of the speed. Acceleration time with maximum inertia and the above load type is 68 seconds. Safe stall time at 100% voltage is 116 seconds cold, 112 seconds hot. Rotor inertia is 0.31 Lb-Ft Sq (0.01 Kg-meter Sq).

Open Circuit A-C:	0.555	Short Circuit D-C:	0.012
Short Circuit A-C:	0.022	X/R Ratio:	4.479
Stator Slots:	36	Rotor Slots:	26

Speed Torque Current Curve (First Connection, First Speed)

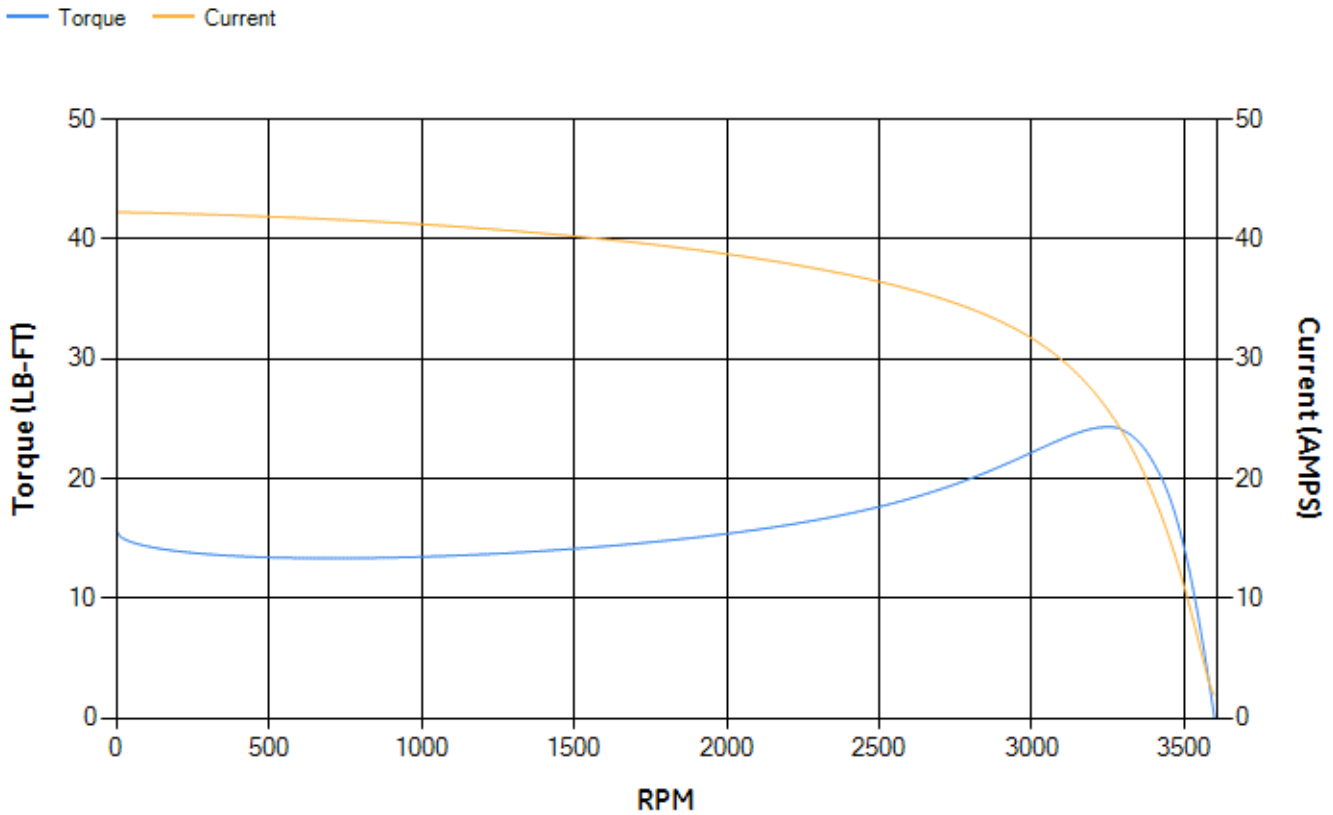

Marks:

NOTE 1: CONDUIT BOX MAY BE ASSEMBLED WITH ENTRANCE UP, DOWN, OR TO EITHER SIDE.
 NOTE 2: THE TOTAL HEIGHT OF PUMP SHAFT & LOCKING NUT ABOVE TOP OF COUPLING, MUST NOT EXCEED THIS DIMENSION.

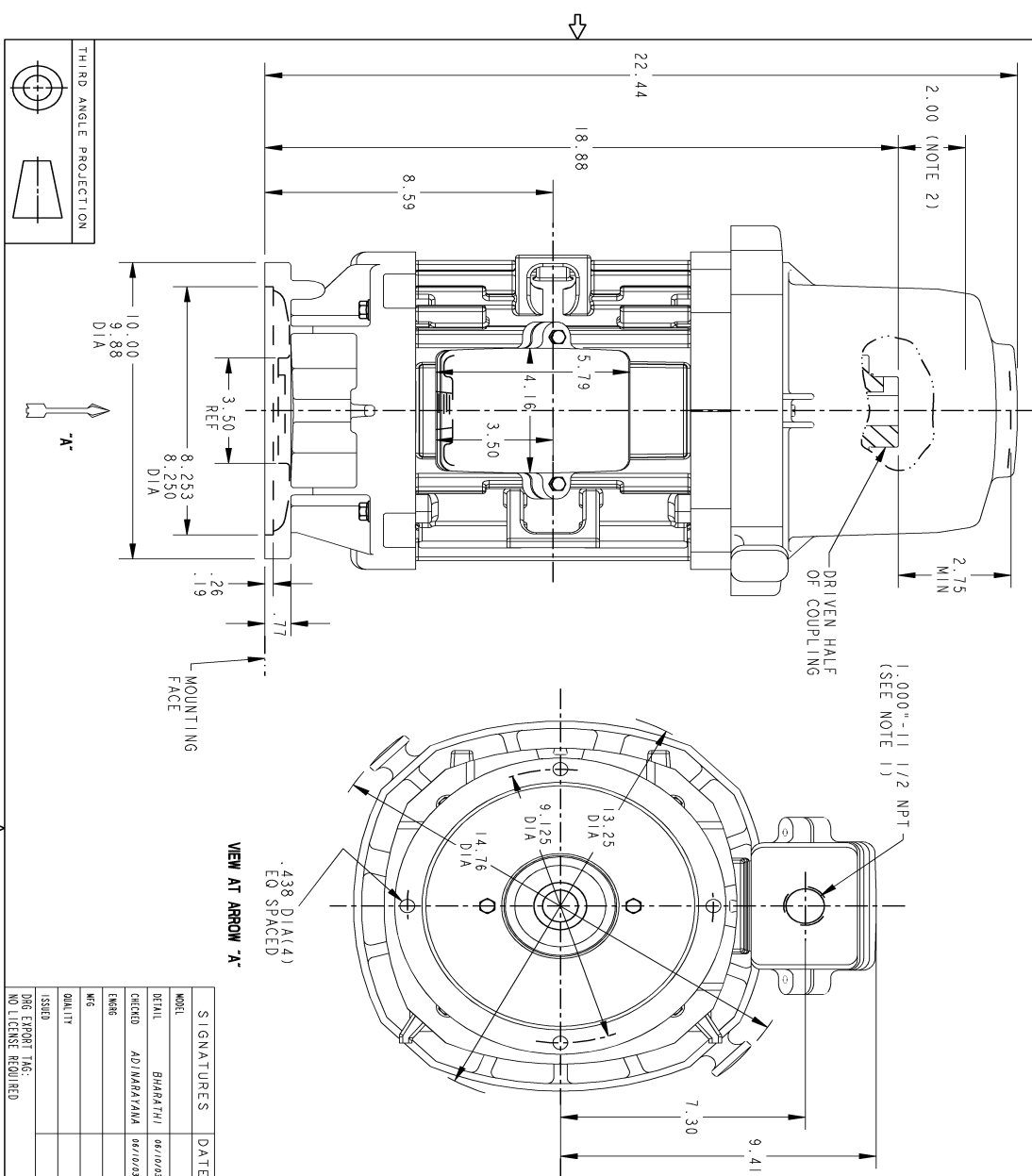

REV.	DESCRIPTION	DATE	APPROVED
1	ISAAC NO: #09-0117 PRADDEP	02/12/09	RAJU
2	ISAAC NO: #16-1067 NAGARAJ	12/28/16	RAVI

BORE DIA.	"B X"	"W"	"D"
1.002	1.001	.250	.125
.939	.938	.188	.094
.877	.876	.250	.125
.816	.815	.188	.094
.752	.751	.250	.125
.690	.689	.188	.094
.628	.627	.250	.125
.566	.565	.188	.094
.504	.503	.250	.125
.442	.441	.188	.094
.380	.379	.250	.125
.318	.317	.188	.094
.256	.255	.250	.125
.194	.193	.188	.094
.132	.131	.250	.125
.070	.069	.188	.094

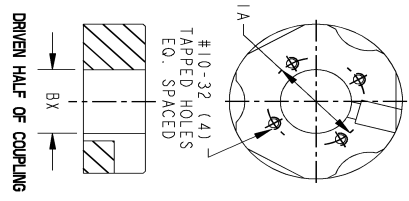

GE POWER CONVERSION

INDUCTION MOTOR OUTLINE
 HOLLOW SHAFT - HIGH THRUST

4002B5821NMP5210 002

SIGNATURES	DATE
DESIGNED: ADINARAYANA	08/10/03
CHECKED: ADINARAYANA	08/10/03
ISSUED:	
DWG EXPORT TAG:	
NO LICENSE REQUIRED	

SCALE: .3

SHEET 1 OF 1

SOLID MODEL: MODEL NAME

SIZE DRAWING NO. 4002B5821NMP5210 002

REV SHEET 1

Marks:

Connection Diagram
GEM2034E-FIG3

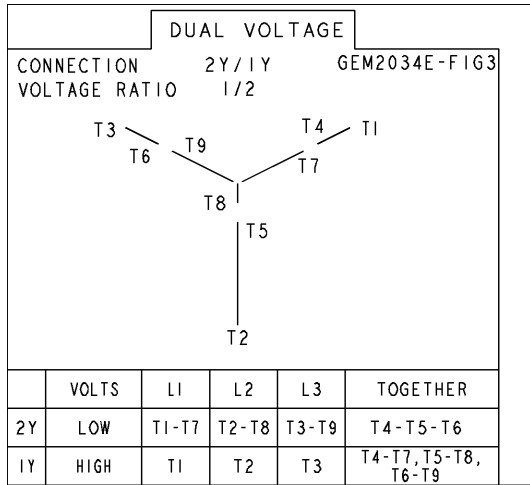

Heater Connection
3027JE-1C



End shield Assembly		
Part Description	DE Side Part#	ODE Side Part#
End Shield	128D6024PA1	128D6025PA1
Bearing	235A2503EJ01	235A2503AA01
Slinger/Inproseal	235A2300FL1	

Fan & Fan Cover Assembly	
Part Description	Part#
Fan	
Fan Cover	

Conduit & Accessories Box Assembly	
Part Description	Part#
Conduit Box	4002B5721PA-G01

Mechanical Accessories	
Part Description	Part#
Brake	
Tachometer	