

CATALOG NO. CD0408		OUTLINE DIMENSIONS 3-PHASE INDUCTION MOTOR		MOTOR TYPE: AEEAGD	
DATE JULY-20-15				FRAME NO. 365T	

Pole	HP	kW	Hz	VOLT	r/min(rpm)
8	40	30	60	230/460	900

Ins	Rating	Dimension in	Approx Weight	Bearings	
F	CONT.	inches	807 lbs.	DE: 6313	NDE: 6213

Totally Enclosed Fan-Cooled Type, Squirrel-Cage Rotor.

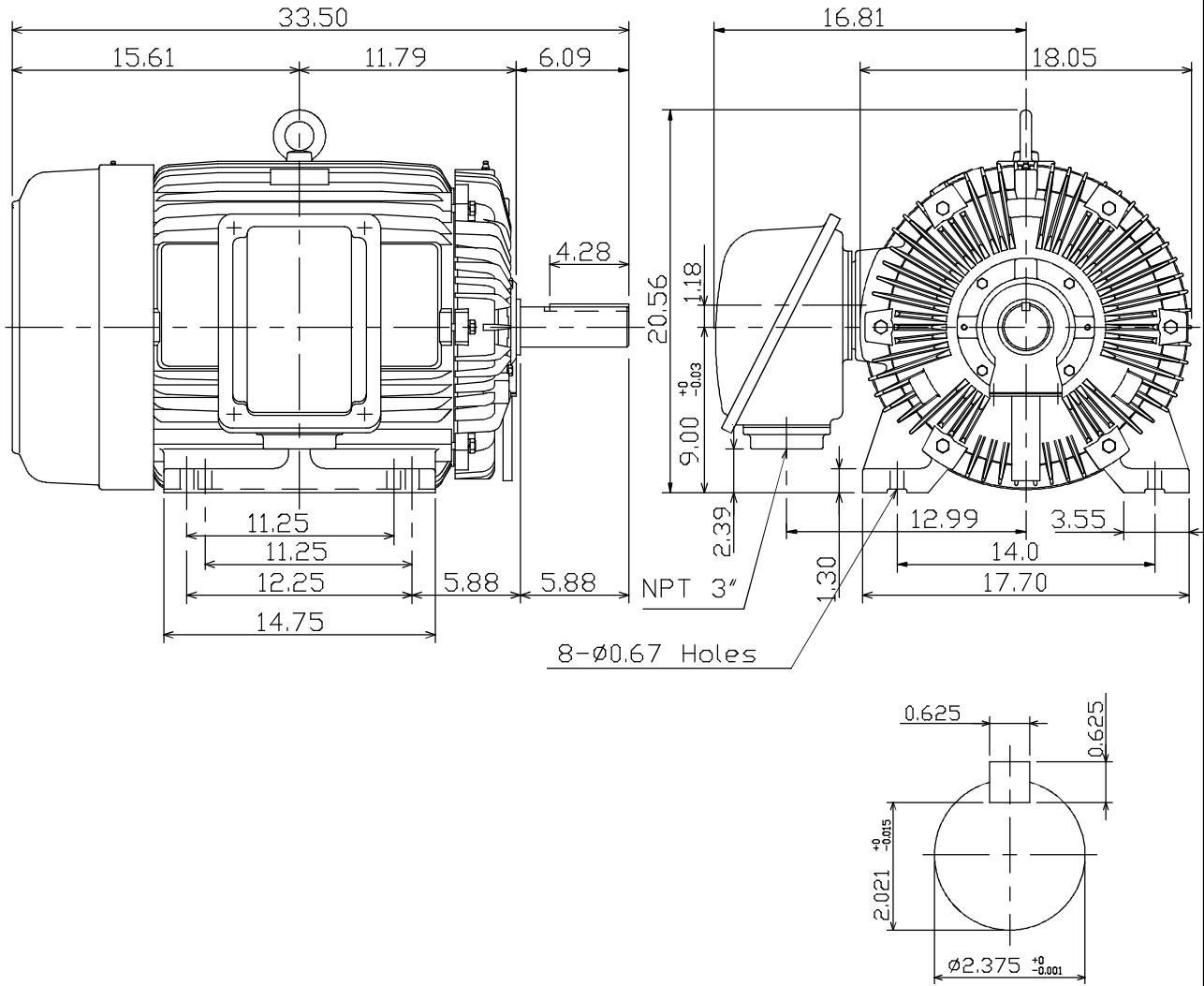

NOTE:

1. ENCLOSURE: IP55
2. SHAFT MATERIAL: SCM440 Q&T (AISI 4140 EQUIV)
3. WITH THERMISTOR: PTC 140°C × 3PCS
WIRED IN MAIN TERMINAL BOX

TW-46C

◇	DWG. C. RAM	07 20 15
---	-------------	----------

DWG.	J.S.LIN	06.15.13	TEC   Westinghouse	DWG NO.	31049J361610
CHKD.	K.L.KUD	06.15.13			
APPD.	C.H.SHYU	06.15.13			