

Product Information Packet

November 8, 2016

Data shown is for the current revision model #. Ensure your nameplate model # matches.

Model Number:	5KS284SAA205D3
Catalog Number:	M9157
Instruction Manual:	GEI-56128
Connection Diagram:	GEM2034E-FIG9
Outline Drawing:	4002B5828PAP5201

Accessory Connection Diagrams			
Bearing Thermocouple:	None	Heater:	None
RTD:	None	Thermistor:	None
Thermostat:	None	Winding Thermocouple:	None
Bearing RTD:	None		

Table of Contents

Specification	01
Performance Characteristics	02
Outline Drawing	03
Connection Drawing(s)	04
Spare parts	05



Marks:

MODEL NUMBER:	5KS284SAA205D3	Estimated Weight:	460 Lbs
Outline Drawing:	4002B5828PAP5201	Time Rating:	CONT
Connection Diagram:	GEM2034E-FIG9	Enclosure:	TEFC
Instruction Book:	GEI-56128	Encl Construction:	X\$D
Design Code:	28BD1162A	Ambient Max(°C):	40
Type:	KS	Alt Ambient Max(°C):	65
Frame:	284T	Insulation Class:	H
Phases:	3	NEMA Design:	B
Poles:	4	Nominal Efficiency:	93.6 %
Output Power:	25HP 18.5KW	Guaranteed Efficiency:	93.0
RPM:	1780	3/4 Load Efficiency:	94.1
Voltage:	230/460	KVA Code:	G
Hertz:	60	Max KVAR:	7.0
Amps - FL:	58.2/29.1	Power Factor:	86.0
Service Factor:	1.25	Bearing - DE:	6310ZC3
Alt Service Factor:	1.00	Bearing - ODE:	6310ZC3

Enclosure is Totally Enclosed Fan-Cooled

Stamped Nameplate Notes:

SF AMPS 72.7/36.4
 STAMP NP249A5564P051 AS BELOW:
 MODEL:5KS284SAA205D3 S/N: XXX
 CSA CERTIFIED CSA09.2216219 FOR EX NA IIC 200C GC
 CL 1 ZONE2 AEX NA IIC 200C;CL 1 DIV2 GRP ABCD 200C
 IN -40C <= AMB <= 40C, 1.0 SF ON SINE-WAVE PWR
 SURF TEMP 215C AT 1.25SF ON SINE-WAVE PWR
 OR 200 C VT OR 200 C CT OR 200 C CHP PWM CONTROL
 ALTERNATE RATING FOR PWM CONTROL 1.0SF 40C AMB
 VT 0-60 HZ, CT 3-60 HZ , CHP 60-90 HZ.

Additional Information:

4P - T EXTN
 STANDARD FLOOR MOUNT
 C/BOX 137 CU IN-1.50 NPT
 F1 CONDUIT BOX MOUNTING
 OIL RESISTANT SLEEVING ON LEADS

Performance Characteristics

1st Winding 1st Connection

Design: 28BD1162A

Marks:

LOAD %	125.0	115.0	100.0	75.0	50.0	25.0	0.0
% EFF	92.52	92.94	93.68	94.08	94.02	91.68	0.00
% PF	86.96	86.73	85.92	82.68	74.44	52.93	4.42
AMPS	36.35	33.38	29.05	22.56	16.72	12.05	9.8

TORQ(FL)#FT	73.83	TORQ(LR)%FL	181.28	TORQ(BD)%FL	286.96
AMPS(LR)	178.14	PF AT START	0.38		

This motor is capable of two cold or one hot start with a maximum connected load inertia of 887 Lb-Ft Sq (37.34 Kg-meter Sq) at 100% voltage, where the load torque varies with the square of the speed. Acceleration time with maximum inertia and the above load type is 56 seconds. Safe stall time at 100% voltage is 100 seconds cold, 67 seconds hot. Rotor inertia is 4.93 Lb-Ft Sq (0.21 Kg-meter Sq).

Open Circuit A-C:	0.627	Short Circuit D-C:	0.016
Short Circuit A-C:	0.028	X/R Ratio:	5.887
Stator Slots:	48	Rotor Slots:	40

Speed Torque Current Curve (First Connection, First Speed)

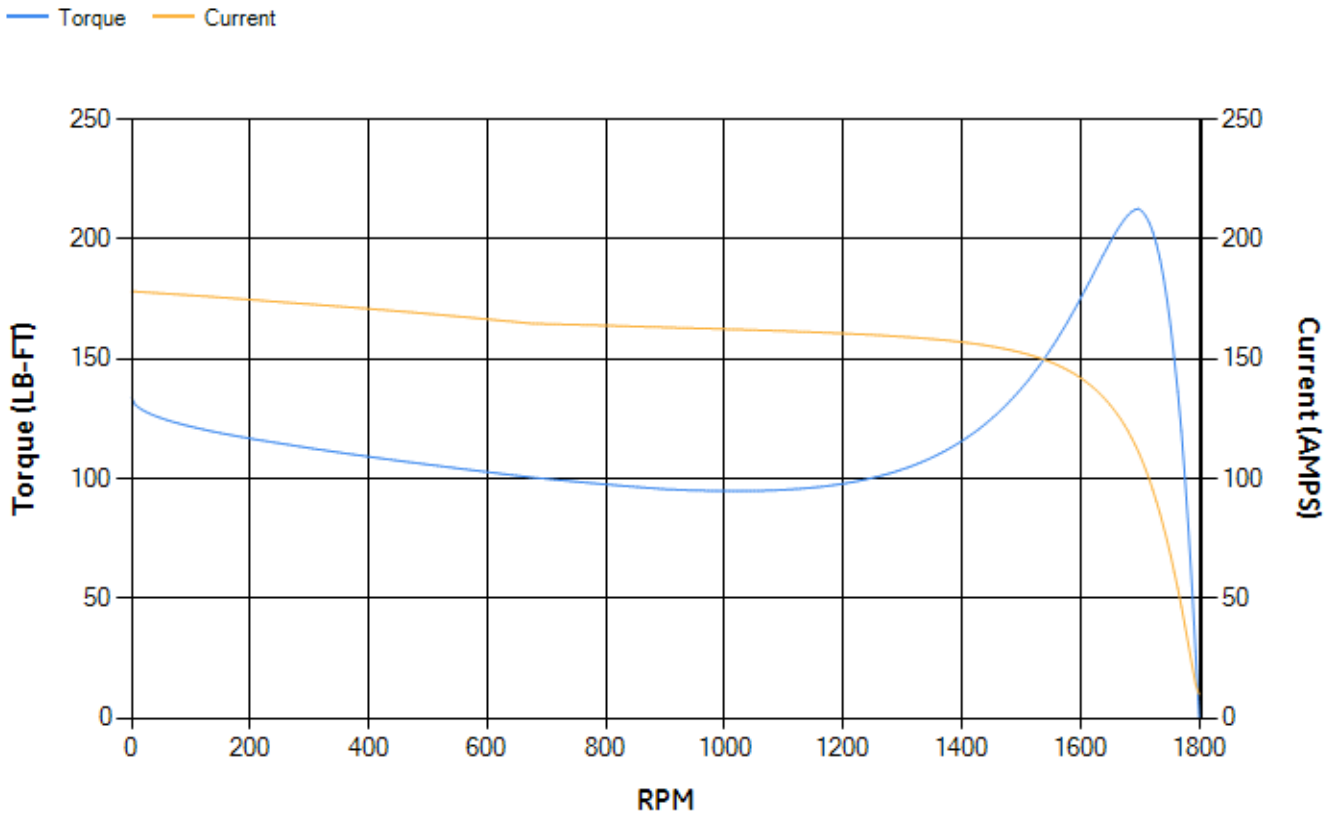

Marks:

NOTE 1: CONDUIT BOX MAY BE ASSEMBLED WITH ENTRANCE UP, DOWN OR TO EITHER SIDE.
 NOTE 2: F1 ASSEMBLY AS SHOWN. F2 ASSEMBLY CONDUIT BOX ON OPPOSITE SIDE FROM SHOWN LOCATION.

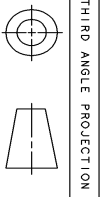
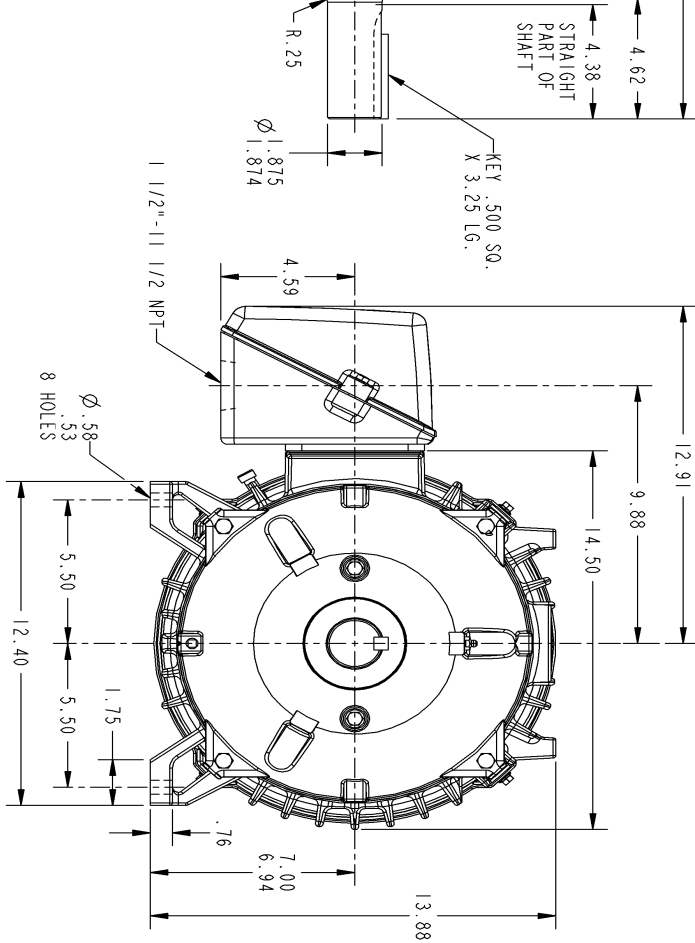
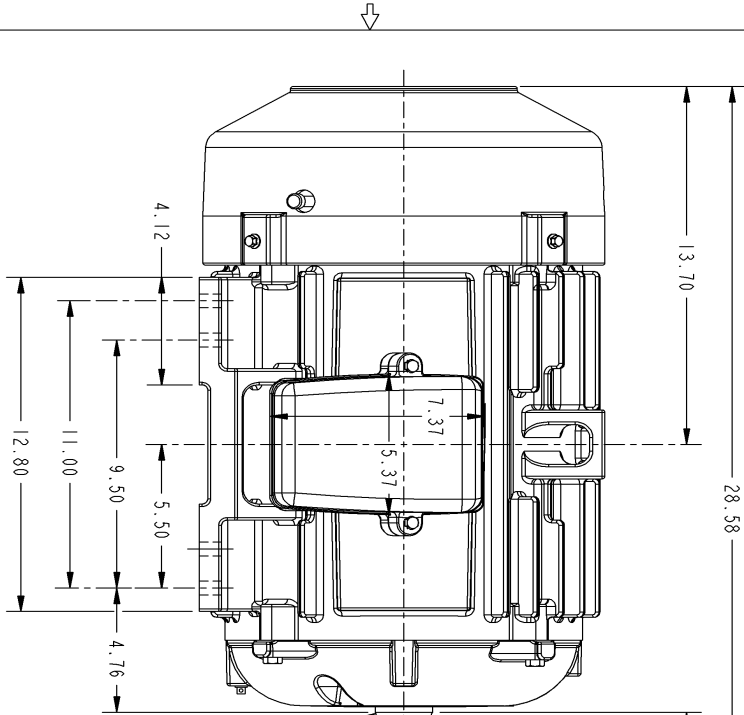

SIZE: B
 PART NUMBER: 4002B5828PAP5201

SM: 0
 REV: 0

REV.	DESCRIPTION	DATE	APPROVED

SIGNATURES	DATE	REV.
DRWN: GARY WARDNER	DEC 13/01	0
CHECKED: GARY WARDNER	FEB 28/02	
ISSUED: GARY WARDNER	MAR 03/02	

APPLIED PRACTICES: B

SCALE: 0.250 REF. NO.: 4002B5828PAP5201 SHEET 1 OF 1

GE Industrial Systems
GENERAL ELECTRIC COMPANY
 Fort Wayne, Indiana

INDUCTION MOTOR OUTLINE
 STANDARD CONSTRUCTION
 FME: FR280T TFC XSD ULTRA

SIZE DRAWING: 4002B5828PAP5201
 REV: 0

DISTRIBUTION: PMP-18K15

Marks:

Connection Diagram
GEM2034E-FIG9

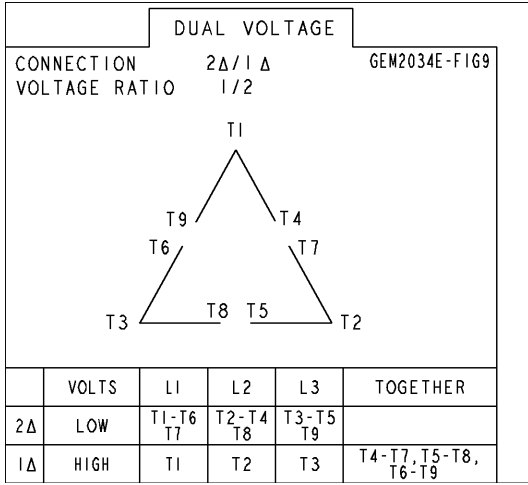

End shield Assembly		
Part Description	DE Side Part#	ODE Side Part#
End Shield	4004D5284PB1	4004D5284SE1
Bearing	235A2608AA01	235A2608AA01
Slinger/Inproseal	149C4399G03	149C4399G03

Fan & Fan Cover Assembly	
Part Description	Part#
Fan	159C6700G02
Fan Cover	4003C5789PA1

Conduit & Accessories Box Assembly	
Part Description	Part#
Conduit Box	4002B5728PA-G01

Mechanical Accessories	
Part Description	Part#
Brake	
Tachometer	