

Product Information Packet

May 6, 2017

Data shown is for the current revision model #. Ensure your nameplate model # matches.

Model Number:	5KS364DAJ6021B
Catalog Number:	V4552
Instruction Manual:	GEK-95353
Connection Diagram:	GEM2034E-FIG7
Outline Drawing:	148CB36VMHKBCLA0001

Accessory Connection Diagrams			
Bearing Thermocouple:	None	Heater:	3027JE-1C
RTD:	None	Thermistor:	None
Thermostat:	None	Winding Thermocouple:	None
Bearing RTD:	None		

Table of Contents

Specification	01
Performance Characteristics	02
Outline Drawing	03
Connection Drawing(s)	04
Spare parts	05



Marks:

MODEL NUMBER:	5KS364DAJ6021B	Estimated Weight:	800 Lbs
Outline Drawing:	148CB36VMHKBCLA0001	Time Rating:	CONT
Connection Diagram:	GEM2034E-FIG7	Enclosure:	WPI
Instruction Book:	GEK-95353	Encl Construction:	OPEN
Design Code:	36BD1236BA	Ambient Max(°C):	40
Type:	KS	Alt Ambient Max(°C):	--
Frame:	L364TP16	Insulation Class:	H
Phases:	3	NEMA Design:	B
Poles:	4	Nominal Efficiency:	95.0 %
Output Power:	60HP 44.4KW	Guaranteed Efficiency:	94.1
RPM:	1785	3/4 Load Efficiency:	--
Voltage:	575	KVA Code:	G
Hertz:	60	Max KVAR:	24.6
Amps - FL:	59.8	Power Factor:	79.5
Service Factor:	1.15	Bearing - DE:	6212C3
Alt Service Factor:	--	Bearing - ODE:	235A2523AD01

Enclosure is Weather Protected One

Stamped Nameplate Notes:

HTR LDS HE1-HE2 115V 100W
 ROT CCW FACING ODE LEAD/PH SEQ 1-2-3/1-2-3
 INVERTER DUTY PER NEMA MG1 PART 31
 ALTERNATE RATING FOR PWM CONTROL:1.0SF 40C AMBIENT
 VAR TORQUE RANGE 5-60 HZ
 UPPER BRG LUBE OIL: 3.7 QTS
 0 DEG C TO 40 DEG C : ISO 32(MINERAL OR SYNTHETIC)
 -15 DEG C TO 0 DEG C : ISO 32 SYNTHETIC

Additional Information:

4P, VERT HOLLOW SHAFT HIGH THRUST (1D)
 C/BOX 346 CU IN - 3.00" NPT
 OIL RESISTANT SLEEVING ON LEADS
 115V HTR LDS TO MAIN CONDUIT BOX
 GROUND PAD
 SHAFT GROUNDING RING MOUNTED ON LOWER END BRG CAP
 BEARING LIFE 8760 HRS AT 6244 LB THRUST
 CG:15.23 IN FROM P-BASE FACE, STAT DEF:0.0033 IN
 RCF:3300 CPM AT C/BOX SIDE, 3270 CPM AT
 90 DEG FROM C/ BOX SIDE
 NON-REVERSE BALL CARRIER
 COUPLING NOT INCLUDED IN BOM, WILL BE
 ORDERED SEPERATELY
 SPECIAL BALANCE

Performance Characteristics

1st Winding 1st Connection

Design: 36BD1236BA

Marks:

LOAD %	125.0	115.0	100.0	75.0	50.0	25.0	0.0
% EFF	94.24	94.39	94.74	94.47	93.6	89.84	0.00
% PF	82.23	81.39	79.51	73.9	62.58	40.35	3.93
AMPS	72.47	67.25	59.49	48.26	38.35	30.98	27.47

TORQ(FL)#FT 176.47
AMPS(LR) 346.5

TORQ(LR)%FL 163.88
PF AT START 0.31

TORQ(BD)%FL 273.11

This motor is capable of two cold or one hot start with a maximum connected load inertia of 1628 Lb-Ft Sq (68.54 Kg-meter Sq)at 100% voltage, where the load torque varies with the square of the speed. Acceleration time with maximum inertia and the above load type is 43 seconds. Safe stall time at 100% voltage is 73 seconds cold, 56 seconds hot. Rotor inertia is 11.21 Lb-Ft Sq (0.47 Kg-meter Sq).

Open Circuit A-C: 0.634

Short Circuit D-C: 0.026

Short Circuit A-C: 0.042

X/R Ratio: 9.709

Stator Slots: 60

Rotor Slots: 50

Speed Torque Current Curve (First Connection, First Speed)

— Torque — Current

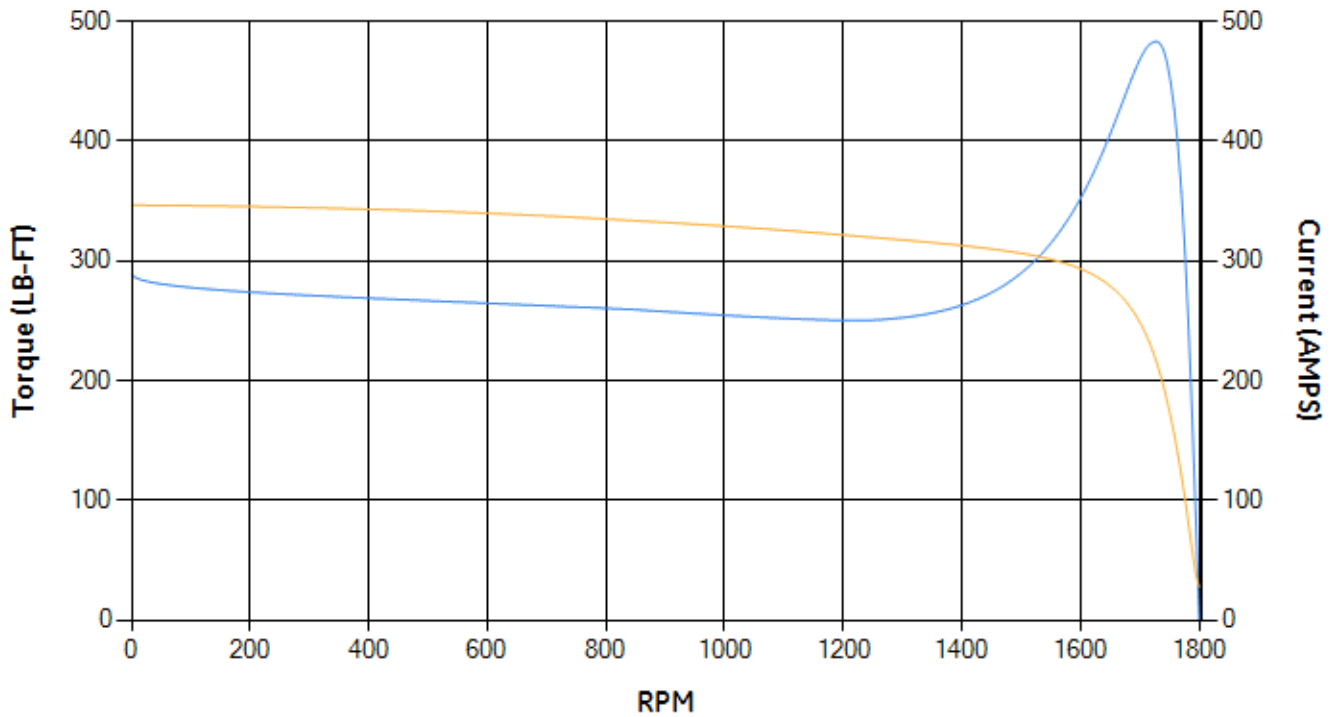

Marks:

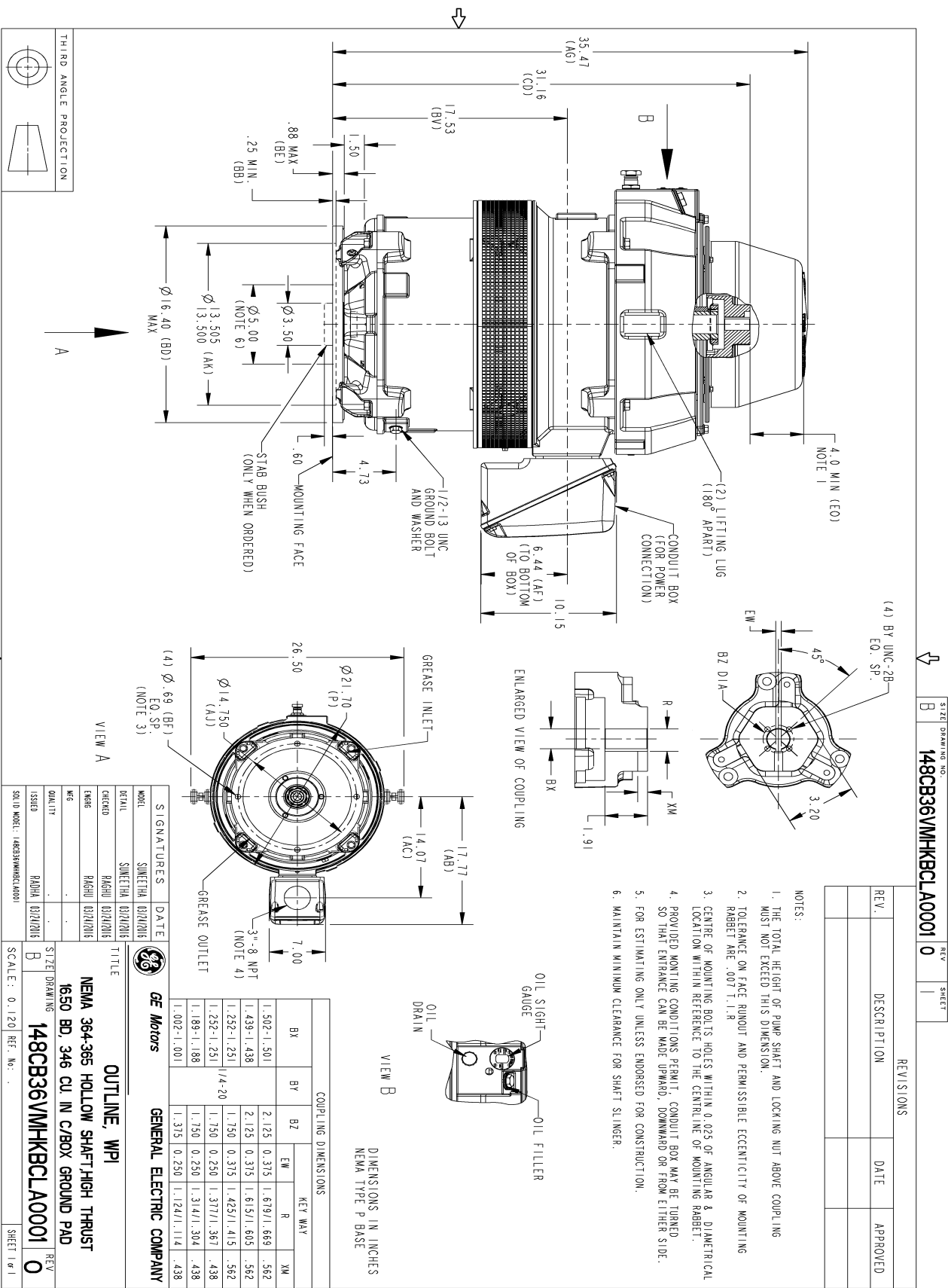

REVISIONS

REV.	DESCRIPTION	DATE	APPROVED
0			

- NOTES:
1. THE TOTAL HEIGHT OF PUMP SHAFT AND LOCKING NUT ABOVE COUPLING MUST NOT EXCEED THIS DIMENSION.
 2. TOLERANCE ON FACE RUNOUT AND PERMISSIBLE ECCENTRICITY OF MOUNTING RABBIT ARE .001 T.1.R
 3. CENTRE OF MOUNTING BOLTS HOLES WITHIN 0.025 OF ANGULAR & DIAMETRICAL LOCATION WITHIN REFERENCE TO THE CENTRAL LINE OF MOUNTING RABBIT.
 4. PROVIDED MOUNTING CONDITIONS PERMIT, CONDUIT BOX MAY BE TURNED SO THAT ENTRANCE CAN BE MADE UPWARD, DOWNWARD OR FROM EITHER SIDE.
 5. FOR ESTIMATING ONLY UNLESS ENDORSED FOR CONSTRUCTION.
 6. MAINTAIN MINIMUM CLEARANCE FOR SHAFT SLINGER.

SIZE DRAWING NO. **B** 148CB36VMHKBLA0001 0

SIGNATURES

MODEL	DATE
SINJETA 03/24/2016	
RAJOU 03/24/2016	
RAJOU 03/24/2016	
RAJOU 03/24/2016	

SCALE: 0.120 REF. No. SHEET 1 OF 1

OUTLINE, WPI

NEMA 364-365 HOLLOW SHAFT-HIGH THRUST

1650 BD 346 CU IN C/BOX GROUND PAD

148CB36VMHKBLA0001

Marks:

Connection Diagram
GEM2034E-FIG7

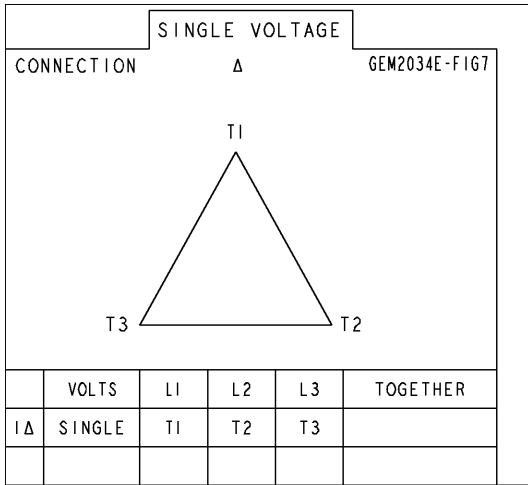

Heater Connection
3027JE-1C



End shield Assembly		
Part Description	DE Side Part#	ODE Side Part#
End Shield	115E7255AA1	115E7259LA1
Bearing	235A2509BE01	235A2523AD01
Slinger/Inproseal	235A2300FM1	

Fan & Fan Cover Assembly	
Part Description	Part#
Fan	
Fan Cover	161C1053AA1

Conduit & Accessories Box Assembly	
Part Description	Part#
Conduit Box	149C4429AA2

Mechanical Accessories	
Part Description	Part#
Brake	
Tachometer	