

TYPE	OUTPUT		POLE	TIME RATING	VOLTAGE V	Hz	SYN.SPEED R.P.M
	HP.	kW.					
AEEAGD	150	112	8	CONT.	230/460	60	900

TOTALLY ENCLOSED FAN-COOLED TYPE, SQUIRREL-CAGE ROTOR

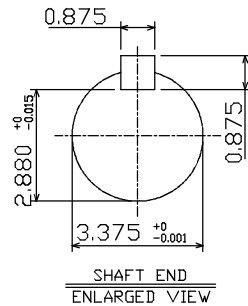
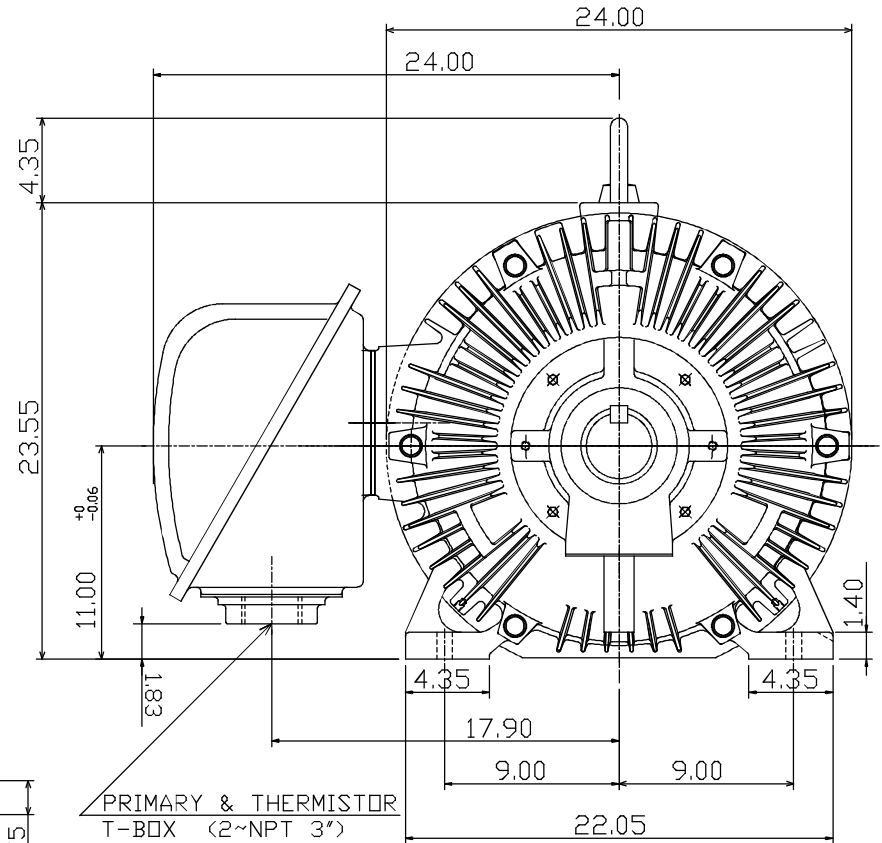
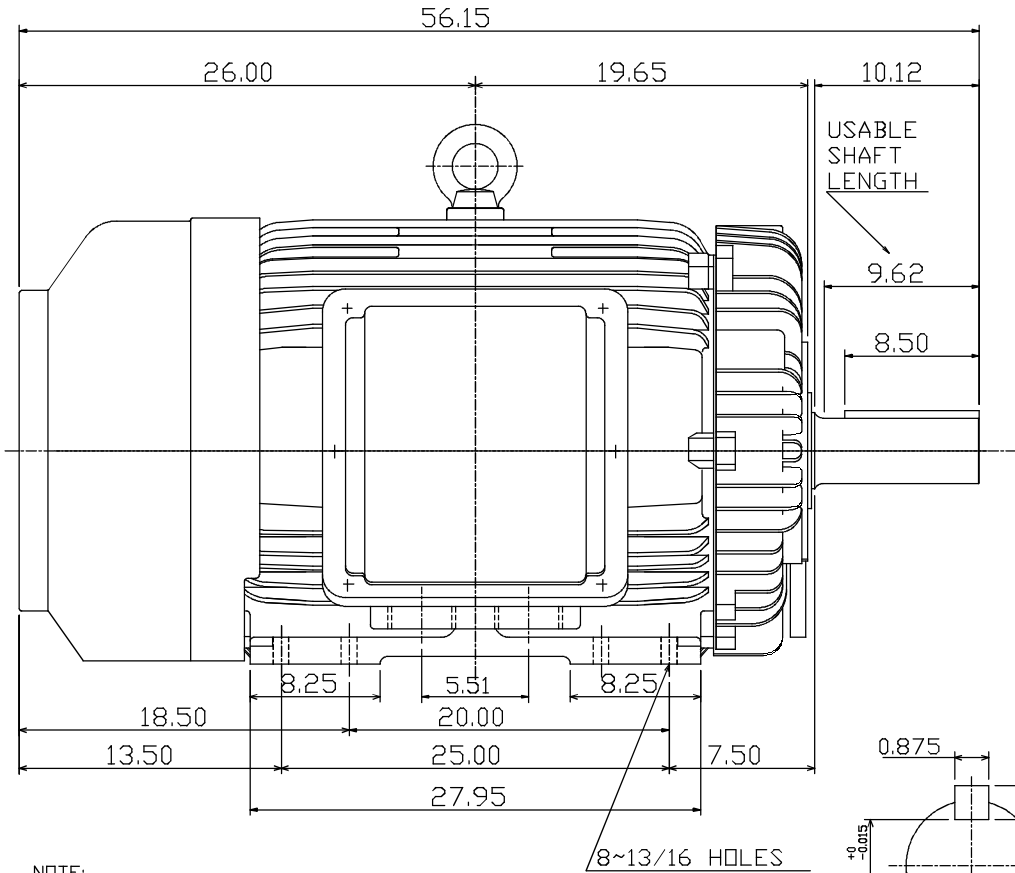

NOTE:

1. DIMENSIONS IN INCHES
2. FRAME NO. 449TZ
3. F CLASS INSULATION, S.F.1.15
4. FOR BELT SERVICE
5. BEARING SIZE: DRIVE END: NU320C3
NON-DRIVE END: 6316C3
6. ENCLOSURE: IP55
7. WITH THERMISTOR: PTC 140°C 3PCS
8. SHAFT MATERIAL: SCM440 Q&T (AISI 4140 EQUIV)
9. CORROSION PROOF
10. MOTOR APPROX. WEIGHT: 2800 LBS

TW-56BC

DWN.	C. RAM	DEC 01 2015	CATALOG NO.
DWN.	S.LEE	DEC•22•2006	CD1508R
CHKD.	S.LEE	DEC•22•2006	TEC Westinghouse
APPD.	C.WANG	DEC•22•2006	

OUTLINE DIMENSIONS
3-PHASE INDUCTION MOTOR

DWG NO. REV: 00
3B040R345