

# Product Information Packet

November 9, 2016

Data shown is for the current revision model #. Ensure your nameplate model # matches.

<b>Model Number:</b>	<b>5KS254XAA100D2</b>
<b>Catalog Number:</b>	<b>M8933</b>
<b>Instruction Manual:</b>	GEI-56128
<b>Connection Diagram:</b>	GEM2034E-FIG1
<b>Outline Drawing:</b>	4002B5825PBP5311

Accessory Connection Diagrams			
<b>Bearing Thermocouple:</b>	None	<b>Heater:</b>	None
<b>RTD:</b>	None	<b>Thermistor:</b>	None
<b>Thermostat:</b>	None	<b>Winding Thermocouple:</b>	None
<b>Bearing RTD:</b>	None		

## Table of Contents

Specification	01
Performance Characteristics	02
Outline Drawing	03
Connection Drawing(s)	04
Spare parts	05



**Marks:**

<b>MODEL NUMBER:</b>	<b>5KS254XAA100D2</b>	<b>Estimated Weight:</b>	315 Lbs
<b>Outline Drawing:</b>	4002B5825PBP5311	<b>Time Rating:</b>	CONT
<b>Connection Diagram:</b>	GEM2034E-FIG1	<b>Enclosure:</b>	TEFC
<b>Instruction Book:</b>	GEI-56128	<b>Encl Construction:</b>	841
<b>Design Code:</b>	25BD0090A	<b>Ambient Max(°C):</b>	40
<b>Type:</b>	KS	<b>Alt Ambient Max(°C):</b>	--
<b>Frame:</b>	254TC	<b>Insulation Class:</b>	H
<b>Phases:</b>	3	<b>NEMA Design:</b>	B
<b>Poles:</b>	2	<b>Nominal Efficiency:</b>	91 %
<b>Output Power:</b>	15HP 11.1KW	<b>Guaranteed Efficiency:</b>	90.2
<b>RPM:</b>	3550	<b>3/4 Load Efficiency:</b>	91.8
<b>Voltage:</b>	460	<b>KVA Code:</b>	G
<b>Hertz:</b>	60	<b>Max KVAR:</b>	2.9
<b>Amps - FL:</b>	17.3	<b>Power Factor:</b>	89.0
<b>Service Factor:</b>	1.15	<b>Bearing - DE:</b>	6310ZC3
<b>Alt Service Factor:</b>	--	<b>Bearing - ODE:</b>	6309ZC3

**Enclosure is Totally Enclosed Fan-Cooled**

**Stamped Nameplate Notes:**

IEEE-STD-841-2009  
 DE BRG 50BC03JP30 ODE BRG 45BC03JP30  
 STAMP NP249A5564P051 AS BELOW:  
 MODEL:5KS254XAA100D2 S/N: XXX  
 CSA CERTIFIED CSA09.2216219 FOR EX NA IIC 200 C GC  
 CL1ZONE2 AEXNAIIC 200 C; CL1DIV2 GRP ABCD 200 C  
 IN -25C <= AMB <= 40C, 1.0 SF ON SINE-WAVE PWR  
 SURF TEMP 230 C AT 1.15 SF ON SINE-WAVE PWR  
 OR 200 C VT OR 215 C CT OR 200 C CHP PWM CONTROL  
 ALTERNATE RATING FOR PWM CONTROL 1.0 SF 40 C AMB  
 VT 0-60 HZ, CT 3-60 HZ, CHP 60-90 HZ.

**Additional Information:**

2P - T EXTN  
 STANDARD FLOOR MOUNT  
 C/BOX 137 CU IN-1.25 NPT  
 F1 CONDUIT BOX MOUNTING  
 "C" FACE AT DE ENDSHIELD  
 PAINTED FRAME ID & SHAFT,  
 FAN COVER INSIDE & ODE E/S OUTSIDE  
 ROUTINE AND 5 POINT VIBRATION TESTS INCL IN C/BOX  
 INPRO SEAL BOTH ENDS  
 GROUND SCREW ON FRAME  
 ROTATE D.E. E/SHIELD 90 DEG. PER OUTLINE  
 SHAFT RUNOUT LIMIT .001" TIR  
 COPPER WASHER UNDER HEADS OF BEARING CAP BOLTS  
 APPLY TITE-SEAL (A50CD427A) ON BEARING CAP SCREWS, RABBETS,

AND PLUG THREADS  
OIL RESISTANT SLEEVING ON LEADS

**Performance Characteristics**

1st Winding 1st Connection

**Design: 25BD0090A**

**Marks:**

LOAD %	125.0	115.0	100.0	75.0	50.0	25.0	0.0
% EFF	89.46	90.13	91.15	91.83	91.73	88.48	0.00
% PF	88.61	89.02	89.24	88.25	83.82	67.77	9.58
AMPS	22.14	20.12	17.26	12.99	9.13	5.85	4.01

<b>TORQ(FL)#FT</b>	22.19	<b>TORQ(LR)%FL</b>	182.51	<b>TORQ(BD)%FL</b>	260.79
<b>AMPS(LR)</b>	108.87	<b>PF AT START</b>	0.3		

This motor is capable of two cold or one hot start with a maximum connected load inertia of 109 Lb-Ft Sq (4.59 Kg-meter Sq)at 100% voltage, where the load torque varies with the square of the speed. Acceleration time with maximum inertia and the above load type is 50 seconds. Safe stall time at 100% voltage is 94 seconds cold, 60 seconds hot. Rotor inertia is 1.05 Lb-Ft Sq (0.04 Kg-meter Sq).

<b>Open Circuit A-C:</b>	0.844	<b>Short Circuit D-C:</b>	0.013
<b>Short Circuit A-C:</b>	0.031	<b>X/R Ratio:</b>	4.8
<b>Stator Slots:</b>	36	<b>Rotor Slots:</b>	26

**Speed Torque Current Curve (First Connection, First Speed)**

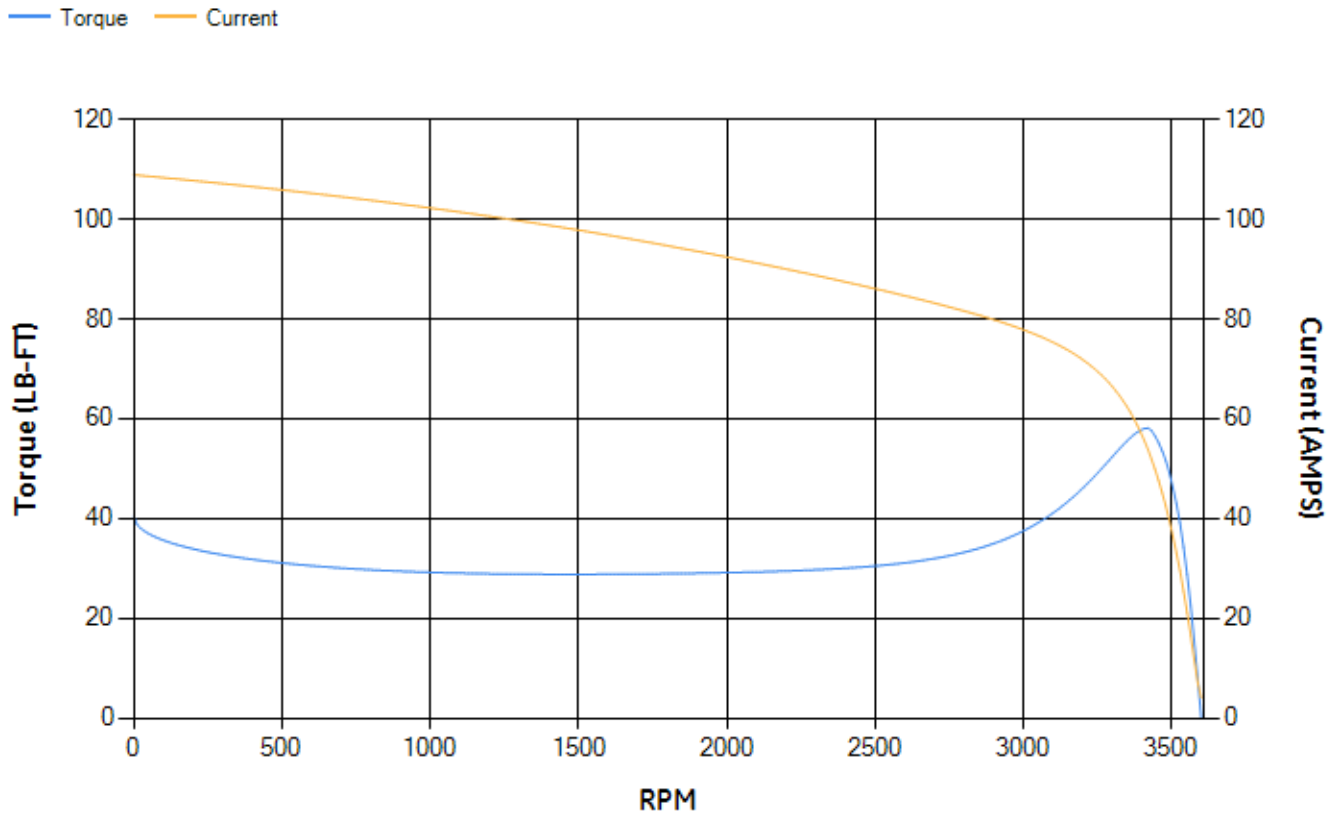

Marks:

NOTE 1: CONDUIT BOX MAY BE ASSEMBLED WITH ENTRANCE UP, DOWN OR TO EITHER SIDE.  
 NOTE 2: F1 ASSEMBLY AS SHOWN. F2 ASSEMBLY CONDUIT BOX ON OPPOSITE SIDE FROM SHOWN LOCATION.  
 NOTE 3: MOUNTING SURFACES WILL BE SQUARE AND CONCENTRIC WITH SHAFT WITHIN .004 T.I.R.  
 NOTE 4: SHAFT RUNOUT WILL NOT EXCEED .001 T.I.R.  
 NOTE 5: DE ENDSHIELD ROTATED 90° COUNTER CLOCKWISE  
 NOTE 6: ALL DIMENSIONS ARE IN INCHES, BRACKETED DIMENSIONS ARE IN METRIC (MILLIMETERS)

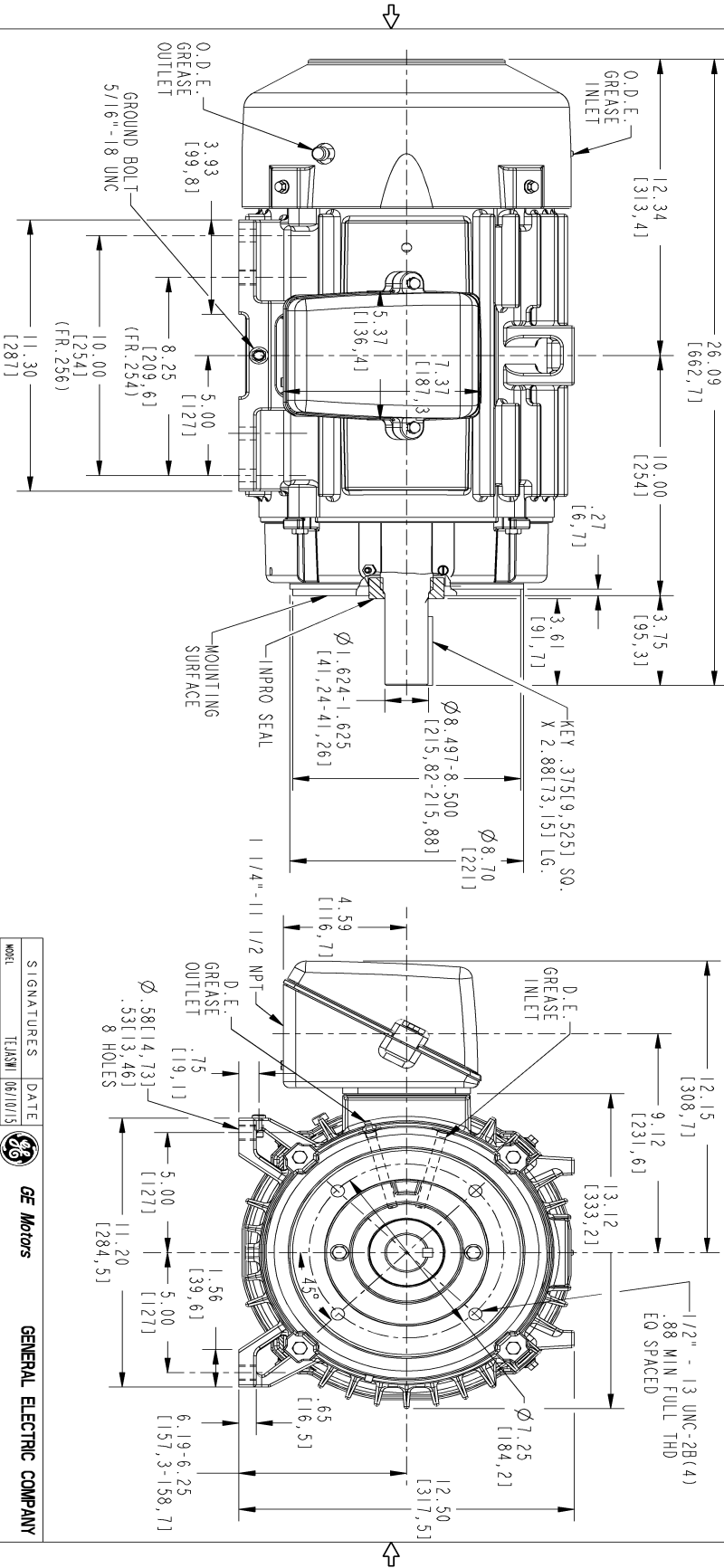

SIZE	DRAWING NO.	REV	SHEET
B	4002B5825PPBP5311	0	1

REV.	DESCRIPTION	DATE	APPROVED

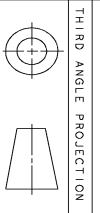

THIRD ANGLE PROJECTION

SIGNATURES	DATE	<b>GE Motors</b> GENERAL ELECTRIC COMPANY
MODEL	TEJASNI 06/10/15	
DETAIL	TEJASNI 06/10/15	TITLE <b>INDUCTION MOTOR OUTLINE</b> IEEE-841 SPEC, "C" FACE AT DRIVE END (85° RABBET) FR: 254/256TC TFC 4002B5825PPBP5311 SCALE: 0.250 REF. No: 4002B5825PPBP5301
CHECKED	AOI 06/10/15	
ENGR	VENKAT 06/10/15	
ISSUED	TEJASNI 06/10/15	
QUALITY		SIZE DRAWING
SOLD MODEL	4002B5825PPBP5311	B
		REV
		0
		SHEET 1 of 1

Marks:

**Connection Diagram**  
**GEM2034E-FIG1**

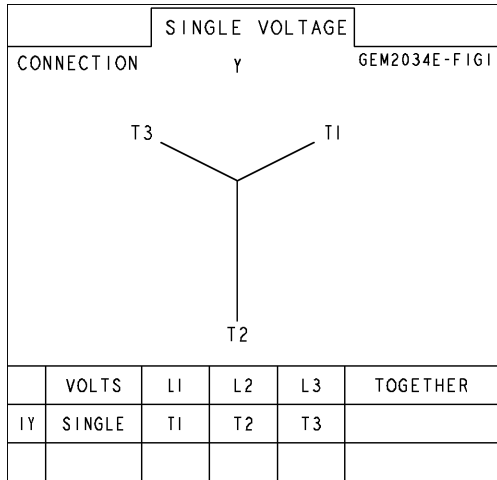

End shield Assembly		
Part Description	DE Side Part#	ODE Side Part#
End Shield	128D6106PM1	4004D5283SE1
Bearing	235A2608AA01	235A2607AA01
Slinger/Inproseal	235A4575GC20	4002B5914AG4

Fan & Fan Cover Assembly	
Part Description	Part#
Fan	159C6704G02
Fan Cover	4003C5788PA1

Conduit & Accessories Box Assembly	
Part Description	Part#
Conduit Box	4002B5728PA-G04

Mechanical Accessories	
Part Description	Part#
Brake	
Tachometer	