

Product Information Packet

November 7, 2016

Data shown is for the current revision model #. Ensure your nameplate model # matches.

Model Number:	5KS365CAG308B
Catalog Number:	E9297
Instruction Manual:	GEI-56128
Connection Diagram:	GEM2034E-FIG7
Outline Drawing:	225B5200AL

Accessory Connection Diagrams			
Bearing Thermocouple:	None	Heater:	None
RTD:	None	Thermistor:	None
Thermostat:	None	Winding Thermocouple:	None
Bearing RTD:	None		

Table of Contents

Specification	01
Performance Characteristics	02
Outline Drawing	03
Connection Drawing(s)	04
Spare parts	05



Marks:

MODEL NUMBER:	5KS365CAG308B	Estimated Weight:	1090 Lbs
Outline Drawing:	225B5200AL	Time Rating:	CONT
Connection Diagram:	GEM2034E-FIG7	Enclosure:	TEFC
Instruction Book:	GEI-56128	Encl Construction:	XP
Design Code:	36ED3041A	Ambient Max(°C):	40
Type:	KS	Alt Ambient Max(°C):	XX
Frame:	365T	Insulation Class:	F
Phases:	3	NEMA Design:	A
Poles:	6	Nominal Efficiency:	94.1 %
Output Power:	50HP 37KW	Guaranteed Efficiency:	93.0
RPM:	1185	3/4 Load Efficiency:	94.8
Voltage:	460	KVA Code:	H
Hertz:	60	Max KVAR:	12.4
Amps - FL:	58.2	Power Factor:	85.5
Service Factor:	1.0	Bearing - DE:	6314ZC3
Alt Service Factor:	XX	Bearing - ODE:	6314ZC3

Enclosure is Totally Enclosed Fan-Cooled

Stamped Nameplate Notes:

EXPLOSION PROOF MOTOR
TEMP CODE T3C
THERMOSTAT LEADS TB1-TB2:TRIP

Additional Information:

STAMP NP235A3573 AS FOLLOWS:
CL I GR C&D CL II GR F&G
6 POLE, T SHAFT EXTN
EXPLOSION PROOF
(3)NC THERMOSTAT LEADS TO MAIN CONDUIT BOX
920 Cu. In. CBOX

Performance Characteristics

1st Winding 1st Connection

Design: 36ED3041A

Marks:

LOAD %	125.0	115.0	100.0	75.0	50.0	25.0	0.0
% EFF	93.4	93.79	94.48	94.83	94.8	92.79	0.00
% PF	85.76	85.74	85.26	82.75	75.72	55.85	4.29
AMPS	73.03	66.93	58.09	44.72	32.6	22.57	17.25

TORQ(FL)#FT	221.29	TORQ(LR)%FL	241.1	TORQ(BD)%FL	263.02
AMPS(LR)	407.85	PF AT START	0.38		

This motor is capable of two cold or one hot start with a maximum connected load inertia of 3106 Lb-Ft Sq (130.76 Kg-meter Sq)at 100% voltage, where the load torque varies with the square of the speed. Acceleration time with maximum inertia and the above load type is 34 seconds. Safe stall time at 100% voltage is 87 seconds cold, 51 seconds hot. Rotor inertia is 32.52 Lb-Ft Sq (1.37 Kg-meter Sq).

Open Circuit A-C:	0.791	Short Circuit D-C:	0.015
Short Circuit A-C:	0.029	X/R Ratio:	5.733
Stator Slots:	72	Rotor Slots:	60

Speed Torque Current Curve (First Connection, First Speed)

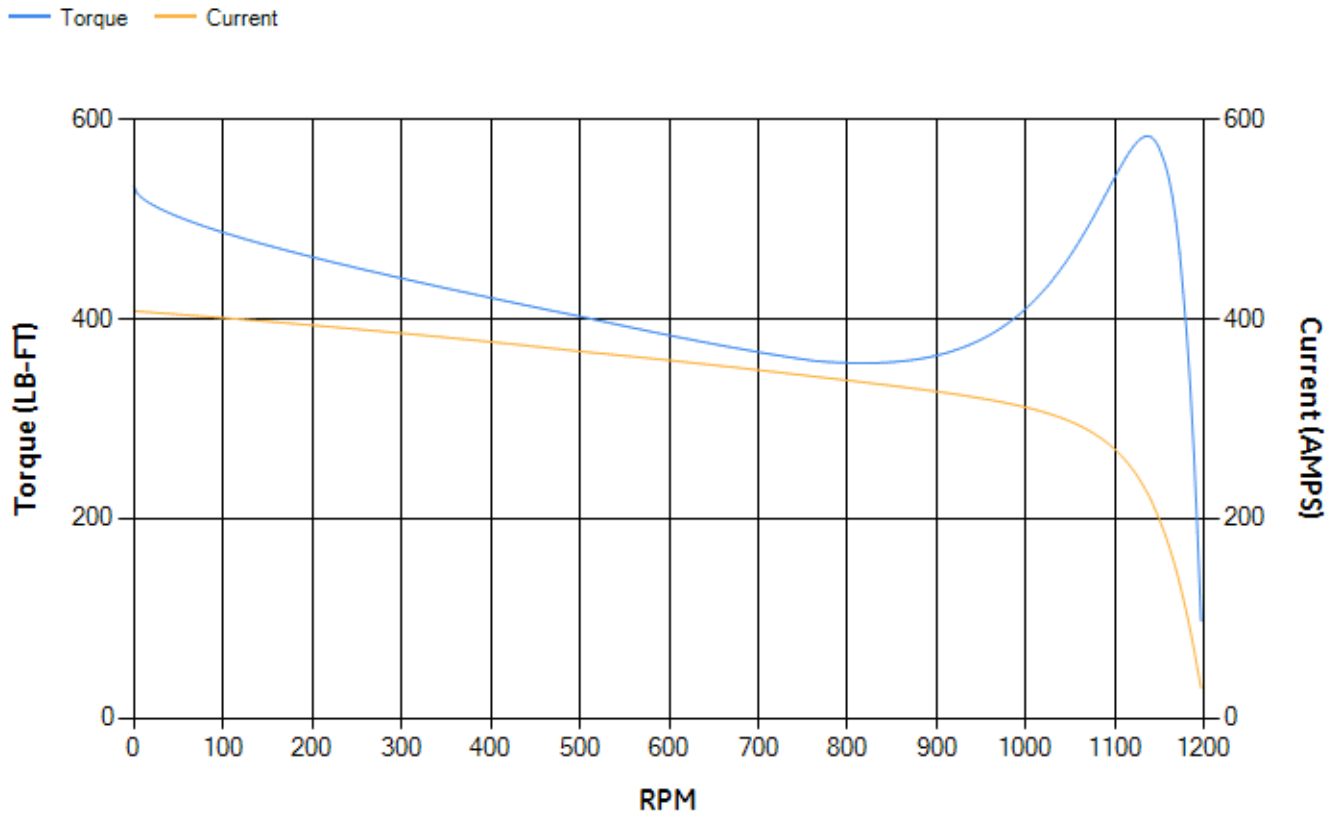

NAME: PT-147 OBJECT: 225B5200AL DATE: 27-Aug-02 14:52:27

Marks:

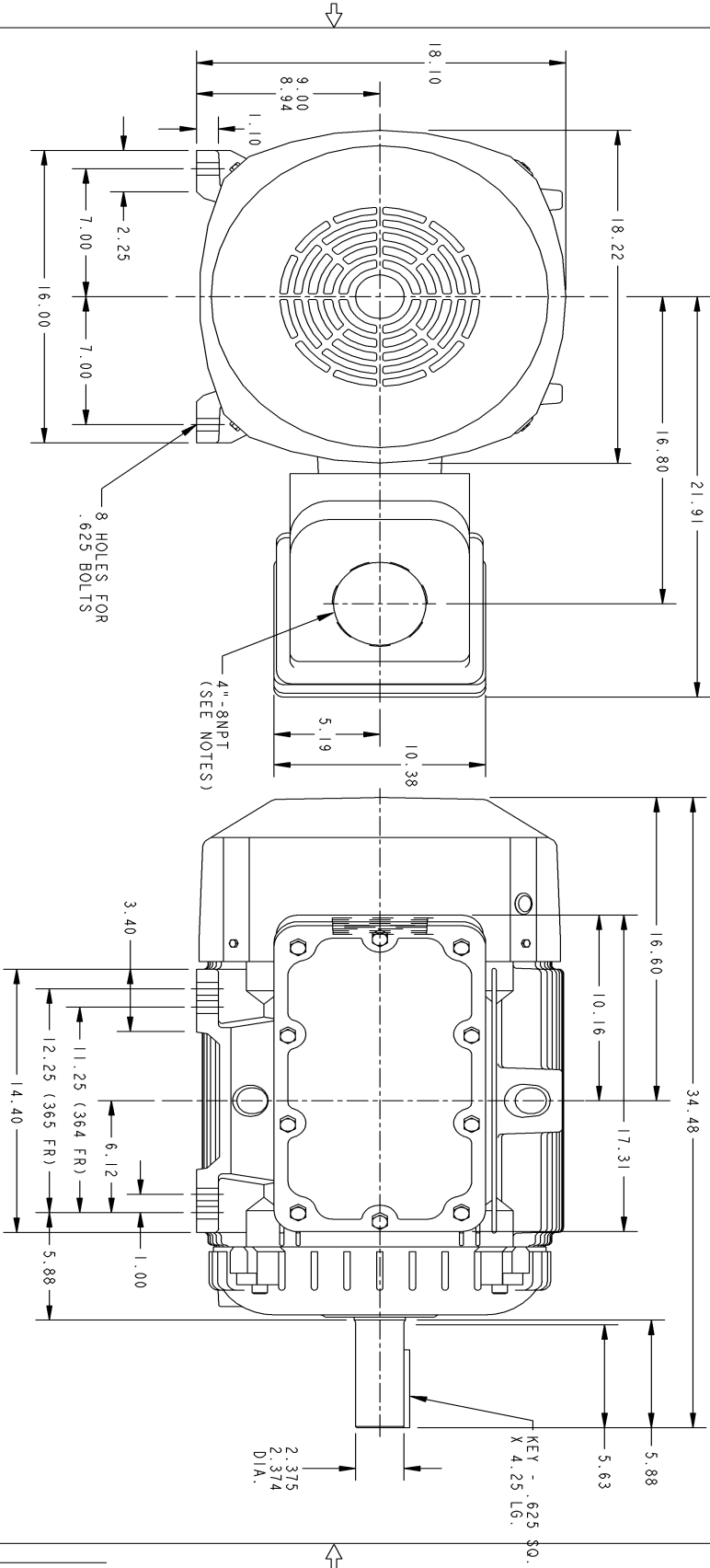

- NOTES:
1. CONDUIT BOX MAY BE PLACED WITH THE ENTRANCE ON EITHER SIDE OR UP.
 2. F-1 ASM AS SHOWN.
 3. F-2 ASM-COND. BOX ON OPPOSITE SIDE.

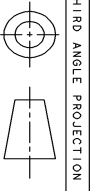

THIRD ANGLE PROJECTION

SHEET B DWG NO 225B5200AL SH REV

REVISIONS			
REV	DESCRIPTION	DATE	APPROVED

UNLESS OTHERWISE SPECIFIED

DIMENSIONS ARE IN INCHES

TOLERANCES ARE:

1. FRACTIONS ± .005

2. PL DECIMALS ± .01

3. PL DECIMALS ± .005

ANGLES ± .5°

SPACINGS ± .005

MATERIALS:

APPLIED PRACTICES:

SIGNATURES	DATE
DRAWN: GWADAM	26-AUG-02
CHECKED: GWADAM	26-AUG-02
ENGINEER:	
ISSUED: GWADAM	26-AUG-02

GE Motors
Fort Wayne, Indiana

OUTLINE

364-365 "T" XP (920 CU. IN. BOX)

CAD NO: OH360-225B5200AL

SIZE: FSCM NO: B

DWG NO: 225B5200AL

SCALE: .19

SHEET: 1 OF 1

DISTR TO:

Marks:

Connection Diagram
GEM2034E-FIG7



End shield Assembly		
Part Description	DE Side Part#	ODE Side Part#
End Shield	128D6482CA1	128D6482CB1
Bearing	235A2516AC01	235A2516AC01
Slinger/Inproseal		

Fan & Fan Cover Assembly	
Part Description	Part#
Fan	159C7100G01
Fan Cover	36FC6450G001

Conduit & Accessories Box Assembly	
Part Description	Part#
Conduit Box	179B9027G01

Mechanical Accessories	
Part Description	Part#
Brake	
Tachometer	