

DATE
APRIL 5, 2010
CAT. #: XP0752C

OUTLINE DIMENSIONS
3-PHASE INDUCTION MOTOR

MOTOR TYPE:
AEHHXF
FRAME NO. 365TSC

Pole	HP	KW	Hz	VOLT	Syn. Speed r/min(rpm)
2	75	56	60	230/460	3600

Ins	Rating	Dimension in	Approx Weight	Bearings
F	CONT.	inches	985 LBS	DE: 6312C3 NDE: 6212C3

Totally Enclosed Fan-Cooled Type. Squirrel-cage Rotor.

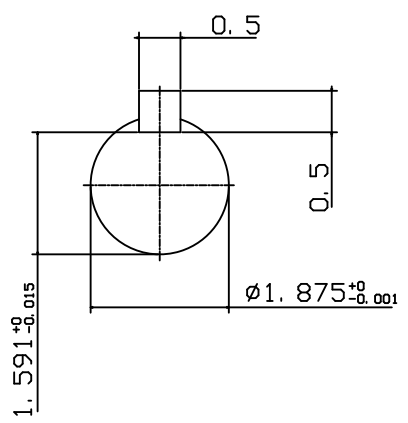
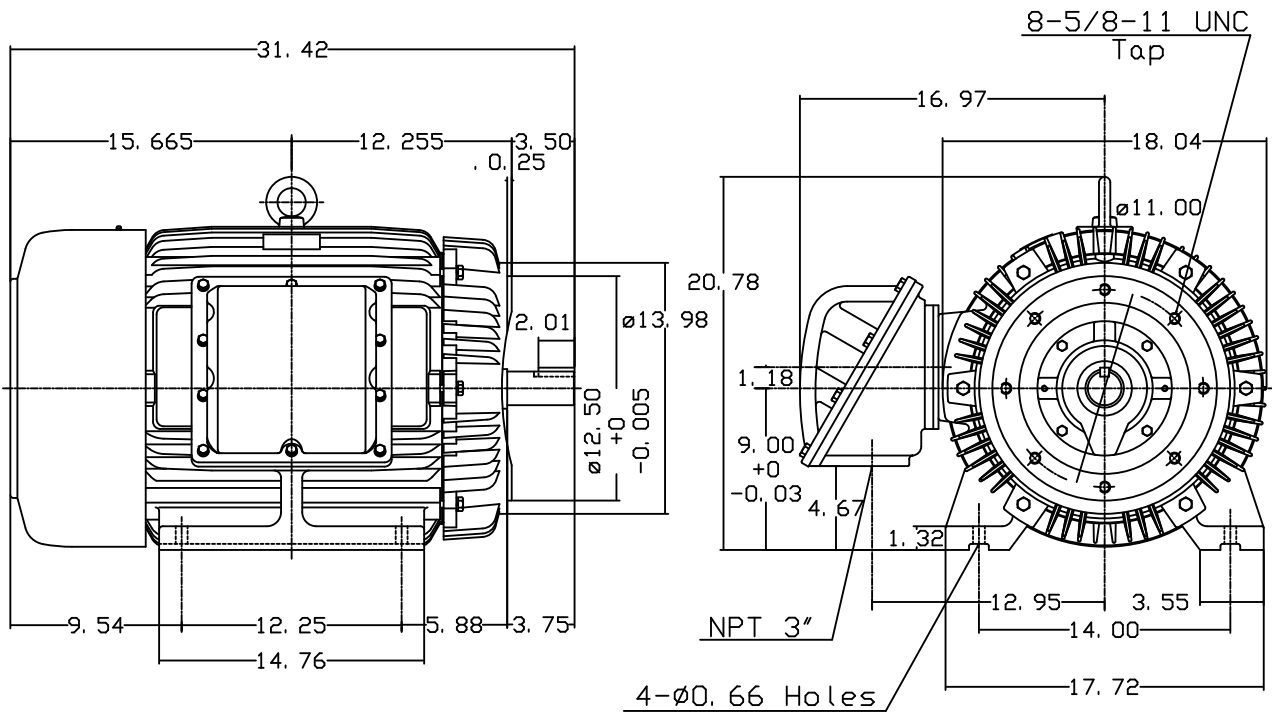

Note:
1. Explosion proof:
Class I Group D and
Class II Group E, F, G.

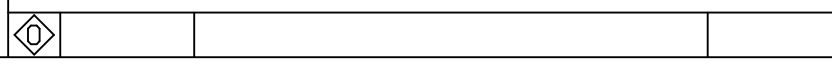

DWN.	J. H. LIANG	11-30-00
CHKD.	C. H. KAO	03-16-01
APPD.	Y. B. HUANG	03-16-01



DWG NO.
31049M632230