

TYPE	OUTPUT		POLE	TIME RATING	VOLTAGE V	Hz	SYN SPEED R.P.M
	HP.	KW.					
AEH8P	200	149.2	4	COND.	460	60	1800

TOTALLY ENCLOSED FAN-COOLED TYPE, SQUIRREL-CAGE ROTOR

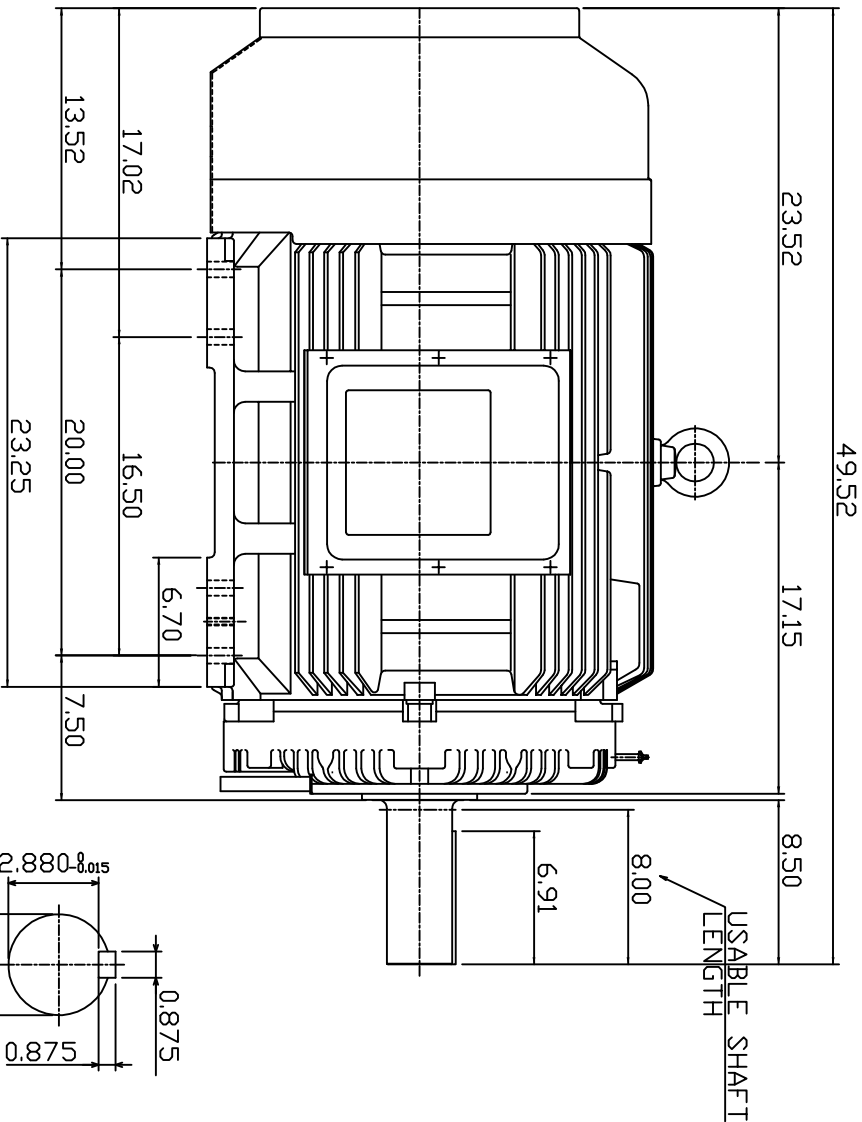
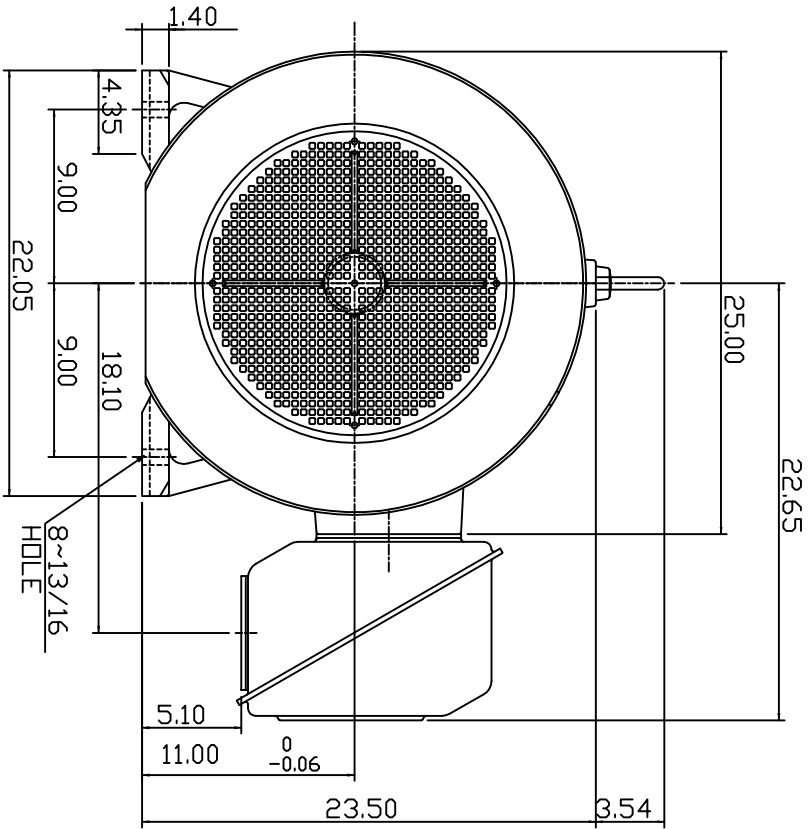

NOTE:

1. DIMENSIONS IN INCHES
2. FRAME SIZE 447T
3. F CLASS INSULATION, S.F. 1.15
4. FOR BELTED APPLICATION
5. BEARING NO.: DRIVE END: NU320C3
DPP, DRIVE END: 6316C3
6. ENCLDSURE: IP44
7. APPRDX. WEIGHT: 2300 LBS

DWN.	SLEE	JAN. 26 2011
CHKD.	SLEE	JAN. 26 2011
APPD.	H.LIU	JAN. 26 2011

DATE
MARCH 2, 2011
CATALOG #:
NP2004R

OUTLINE DIMENSIONS
3-PHASE INDUCTION MOTOR



DWG NO. 3A049DWB10464-27
REV: 00