

(2) 5/16-18
TERMINAL POST

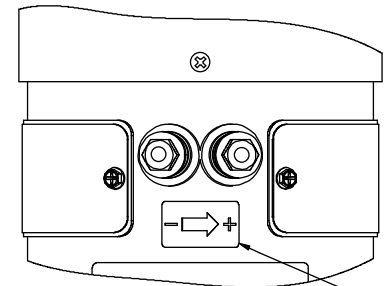

ROTATION
DECAL

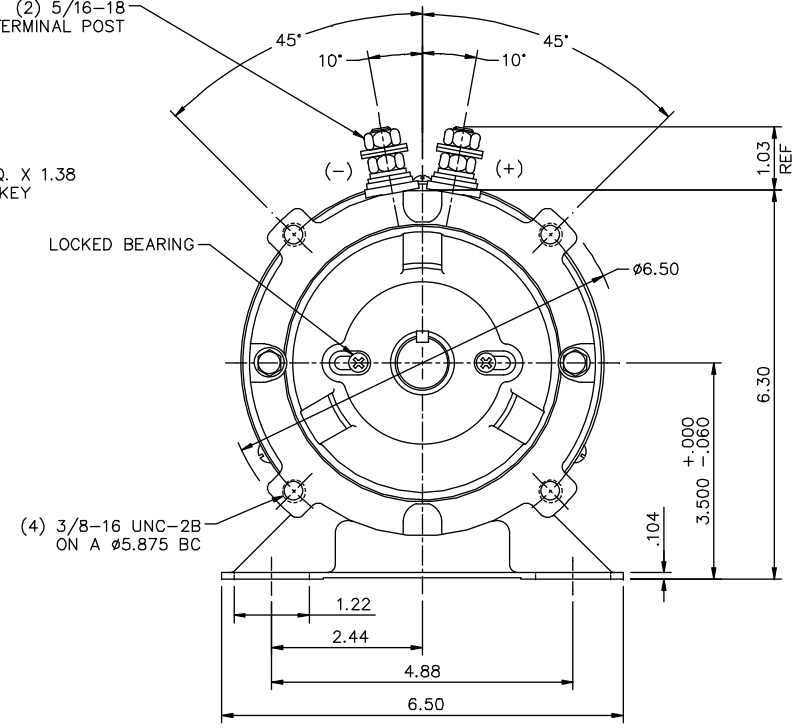

LOCKED BEARING

(4) 3/8-16 UNC-2B
ON A 5.875 BC

- NOTES:
1. MAXIMUM FACE RUNOUT TO BE .004 T.I.R.
 2. MAXIMUM PILOT ECCENTRICITY .004 T.I.R.
 3. PERMISSIBLE SHAFT RUNOUT .002 T.I.R.
 4. GASKETS THROUGHOUT.

		TOLERANCES UNLESS SPECIFIED		MARATHON ELECTRIC		DRAWN			
		DEC.	INCHES			IPG 11/1/13			
		.X	±.1			CHK			
		.XX	±.03	TITLE	OUTLINE - 48 FRAME DC	APPD			
		.XXX	±.005		S56C - 145TC MOUNTING - TURBO	SCALE 1=2			
		.XXXX	±.0005	MAT'L.		REF 031819			
00	RELEASED			FINISH		FMF 058E17F2015			
NO.	REVISION	BY & DATE	CHK	ANG	±1/2'	PREV			
THIS DRAWING IN DESIGN AND DETAIL IS OUR PROPERTY AND MUST NOT BE USED EXCEPT IN CONNECTION WITH OUR WORK ALL RIGHTS OF DESIGN AND INVENTION ARE RESERVED THIS IS AN ELECTRONICALLY GENERATED DOCUMENT - DO NOT SCALE THIS PRINT				RFP	CAD FILE	612-0139	SIZE	DRAWING NO.	REV.
				DIST			B	612-0139	00