

Product Information Packet

November 8, 2016

Data shown is for the current revision model #. Ensure your nameplate model # matches.

Model Number:	5KS184XAA325B
Catalog Number:	M9407
Instruction Manual:	GEI-56128
Connection Diagram:	GEM2034E-FIG1
Outline Drawing:	4002B5818PDP5310

Accessory Connection Diagrams			
Bearing Thermocouple:	None	Heater:	None
RTD:	None	Thermistor:	None
Thermostat:	None	Winding Thermocouple:	None
Bearing RTD:	None		

Table of Contents

Specification	01
Performance Characteristics	02
Outline Drawing	03
Connection Drawing(s)	04
Spare parts	05



Marks:

MODEL NUMBER:	5KS184XAA325B	Estimated Weight:	101 Lbs
Outline Drawing:	4002B5818PDP5310	Time Rating:	CONT
Connection Diagram:	GEM2034E-FIG1	Enclosure:	TEFC
Instruction Book:	GEI-56128	Encl Construction:	841
Design Code:	18BD3002A	Ambient Max(°C):	40
Type:	KS	Alt Ambient Max(°C):	--
Frame:	184TC	Insulation Class:	H
Phases:	3	NEMA Design:	B
Poles:	6	Nominal Efficiency:	88.5 %
Output Power:	2HP 1.5KW	Guaranteed Efficiency:	87.5
RPM:	1170	3/4 Load Efficiency:	88.6
Voltage:	460	KVA Code:	L
Hertz:	60	Max KVAR:	1.2
Amps - FL:	3.0	Power Factor:	69.5
Service Factor:	1.15	Bearing - DE:	6307ZC3
Alt Service Factor:	--	Bearing - ODE:	6206ZC3

Enclosure is Totally Enclosed Fan-Cooled

Stamped Nameplate Notes:

IEEE-STD-841-2009
 DE BRG 35BC03JP30 ODE BRG 30BC02JP30
 STAMP NP249A5564P051 AS BELOW:
 MODEL:5KS184XAA325B S/N: XXX
 CSA CERTIFIED CSA09.2216219 FOR EX NA IIC 200C GC
 CL 1 ZONE2 AEX NA IIC 200C;CL 1 DIV2 GRP ABCD 200C
 IN -25C <= AMB <= 40C, 1.0 SF ON SINE-WAVE PWR
 SURF TEMP 200C AT 1.15SF ON SINE-WAVE PWR
 OR 200 C VT OR 200 C CT OR 200 C CHP PWM CONTROL
 ALTERNATE RATING FOR PWM CONTROL 1.0SF 40C AMB
 VT 0-60 HZ, CT 3-60 HZ, CHP 60-90 HZ.

Additional Information:

6P - T EXTN
 C/BOX 55 CU IN-1.00 NPT
 "C" FACE AT DE ENDSHIELD ROUND FRAME
 VERTICAL MOUNT SHAFT DOWN WITH DRIPCOVER
 PAINTED FRAME ID & SHAFT,
 FAN COVER INSIDE & ODE E/S OUTSIDE
 ROUTINE AND 5 POINT VIBRATION TESTS INCL IN C/BOX
 INPRO SEAL BOTH ENDS
 BURNDY SERVIT POST ON FRAME
 SHAFT RUNOUT LIMIT .001" TIR
 COPPER WASHER UNDER HEADS OF BEARING CAP BOLTS
 APPLY TITE-SEAL (A50CD427A) ON BEARING CAP SCREWS, RABBETS,
 AND PLUG THREADS
 OIL RESISTANT SLEEVING ON LEADS

Performance Characteristics

1st Winding 1st Connection

Design: 18BD3002A

Marks:

LOAD %	125.0	115.0	100.0	75.0	50.0	25.0	0.0
% EFF	87.5	87.94	88.63	88.62	87.32	81.03	0.00
% PF	74.91	73.13	71.47	61.5	48.65	29.78	5.57
AMPS	3.57	3.35	2.96	2.58	2.2	1.94	1.72

TORQ(FL)#FT	8.97	TORQ(LR)%FL	218.45	TORQ(BD)%FL	385.07
AMPS(LR)	22.55	PF AT START	0.46		

This motor is capable of two cold or one hot start with a maximum connected load inertia of 290 Lb-Ft Sq (12.21 Kg-meter Sq)at 100% voltage, where the load torque varies with the square of the speed. Acceleration time with maximum inertia and the above load type is 53 seconds. Safe stall time at 100% voltage is 117 seconds cold, 94 seconds hot. Rotor inertia is 0.41 Lb-Ft Sq (0.02 Kg-meter Sq).

Open Circuit A-C:	0.158	Short Circuit D-C:	0.008
Short Circuit A-C:	0.01	X/R Ratio:	3.192
Stator Slots:	36	Rotor Slots:	48

Speed Torque Current Curve (First Connection, First Speed)

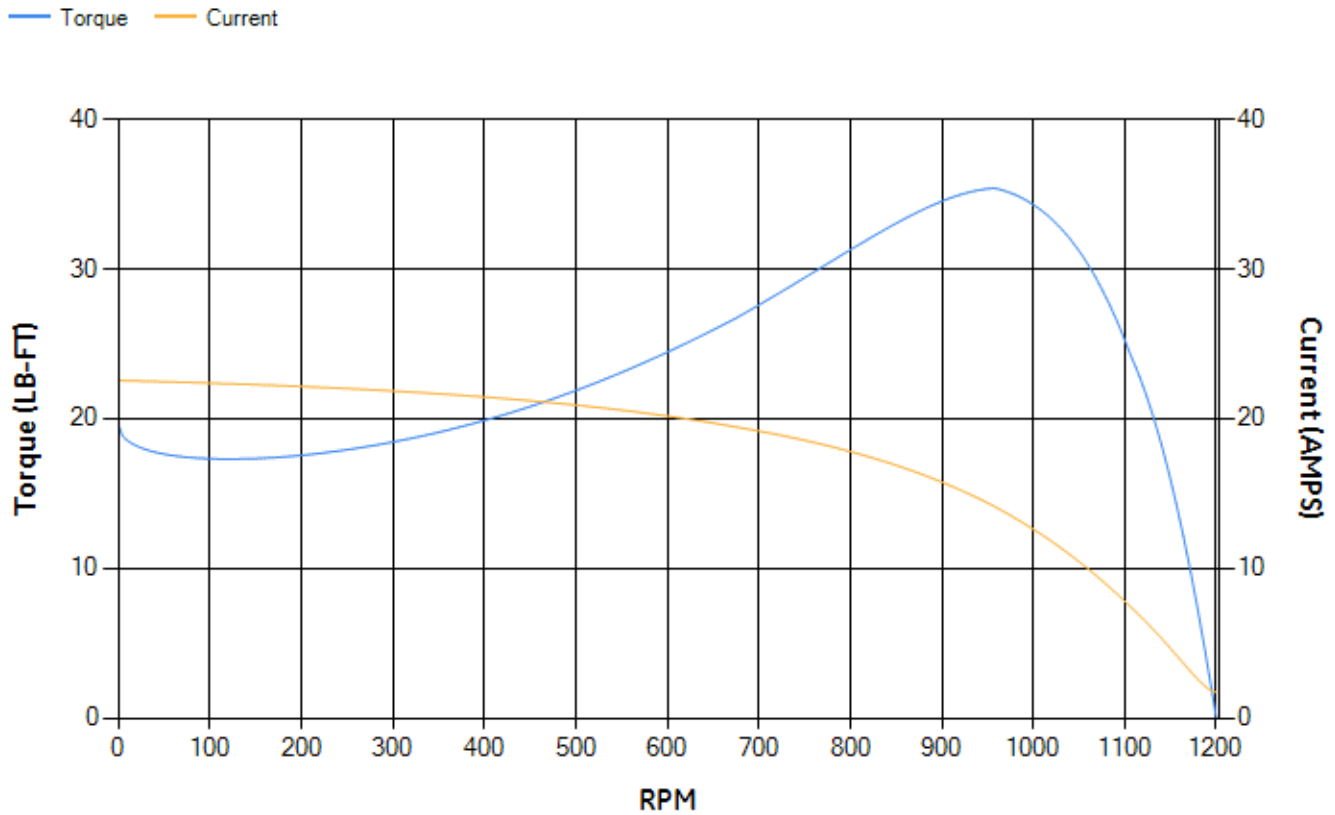

Marks:

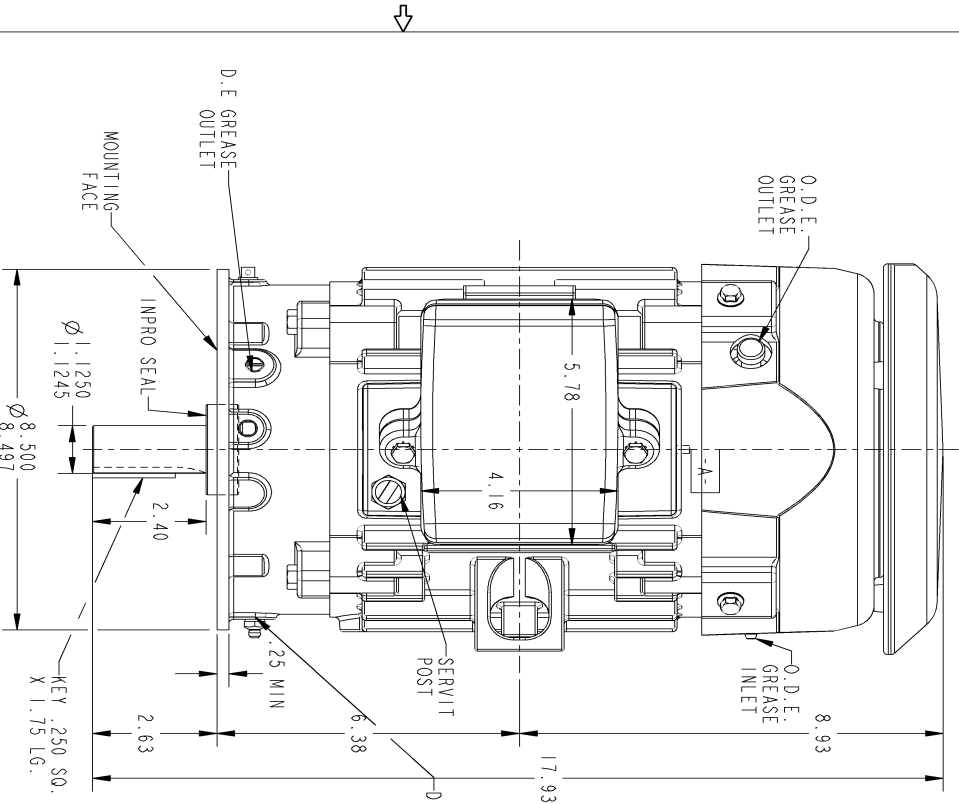

VIEW "A"

- NOTE 1: CONDUIT BOX MAY BE ASSEMBLED WITH ENTRANCE ON EITHER SIDE.
- NOTE 2: F1 ASSEMBLY AS SHOWN. F2 ASSEMBLY CONDUIT BOX ON OPPOSITE SIDE FROM SHOWN LOCATION.
- NOTE 3: MOUNTING SURFACES WILL BE SQUARE AND CONCENTRIC WITH SHAFT WITHIN .004 T.I.R.
- NOTE 4: SHAFT RUNOUT WILL NOT EXCEED .001 T.I.R.

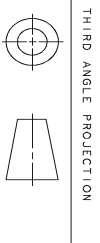

SIZE DRAWING NO. **4002B5818PDP5310** SH REV **4**

REVISIONS		DATE	APPROVED
REV. 1	1" NPT WAS 3/4" NPT N PRASAD	10/9/06	ROOPA
2	REVISED AS PER THE ISAC # 09-0339	04/07/09	DAN
3	ISAC # 10-0924	07/29/11	RAGHU
4	ISAC # 14-0626	08/01/2014	VI JAY

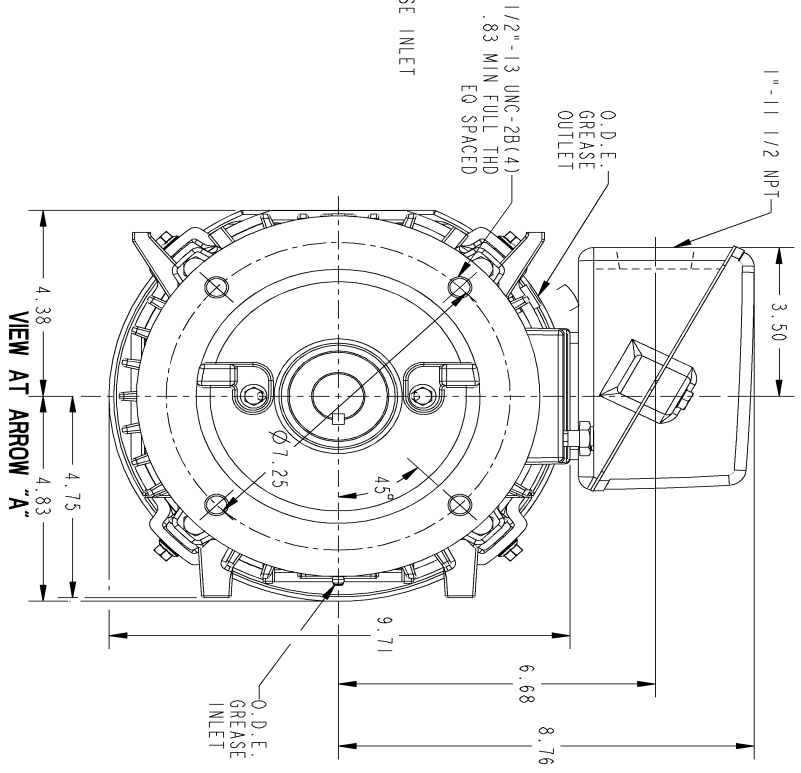

VIEW AT ARROW "A"

SIGNATURES	DATE	APPROVED
DRMAN AMAND 03/09/10	03/09/10	ROOPA
ENGRB DMOHAN 03/09/10	03/09/10	DAN
ISSRD DMOHAN 03/09/10	03/09/10	RAGHU
APPLIED PRACTICES		VI JAY

GE Industrial Systems
INDUCTION MOTOR OUTLINE
 IEEE-941 SPEC C FACE AT DE FOOTLESS WITH DRIP COVER
 FME: 5KS184XAB226 (850° RABBIT)

SIZE DRAWING **4002B5818PDP5310**

SCALE: 0.400 REF. NO. - SHEET 1 OF 1

DISTRIBUTION: PMP-18K15

Marks:

Connection Diagram
GEM2034E-FIG1



End shield Assembly		
Part Description	DE Side Part#	ODE Side Part#
End Shield	4004D5286PE1	4004D5281SG1
Bearing	235A2601AA01	235A2602AA01
Slinger/Inproseal	316A5384AJ1	4002B5914AG2

Fan & Fan Cover Assembly	
Part Description	Part#
Fan	4001A5914AM-G01
Fan Cover	4003C5518BN-G01

Conduit & Accessories Box Assembly	
Part Description	Part#
Conduit Box	4002B5721PA-G01

Mechanical Accessories	
Part Description	Part#
Brake	
Tachometer	