

TYPE	OUTPUT		POLE	TIME RATING	VOLTAGE V	Hz	SYN.SPEED R.P.M
	HP.	kW.					
AEHGTK	125	93.3	2	CONT.	2300/4160	60	3600

TOTALLY ENCLOSED FAN-COOLED TYPE. SQUIRREL-CAGE ROTOR

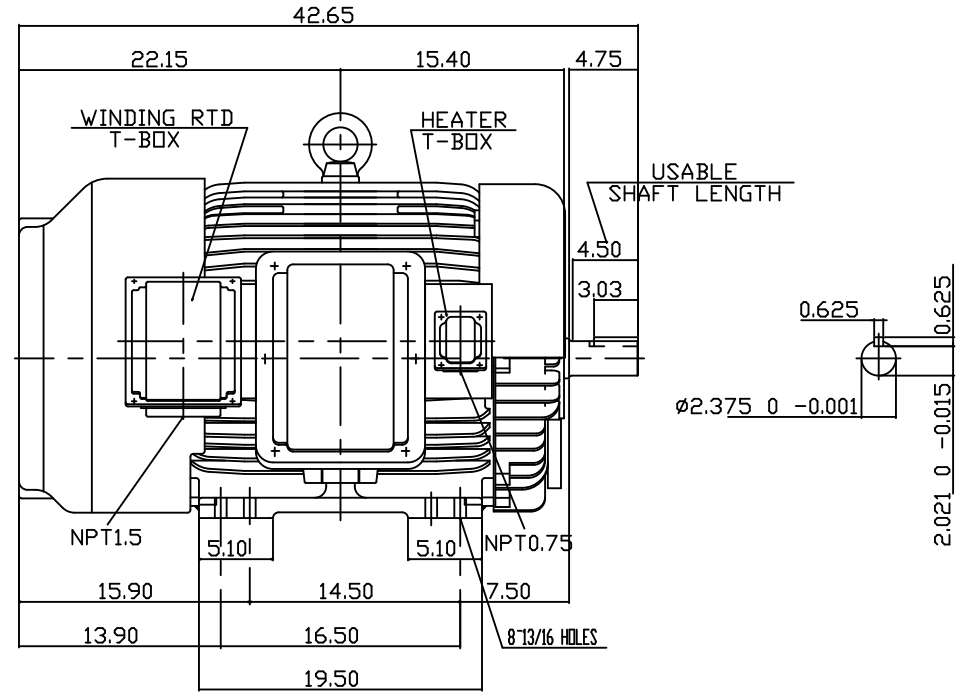
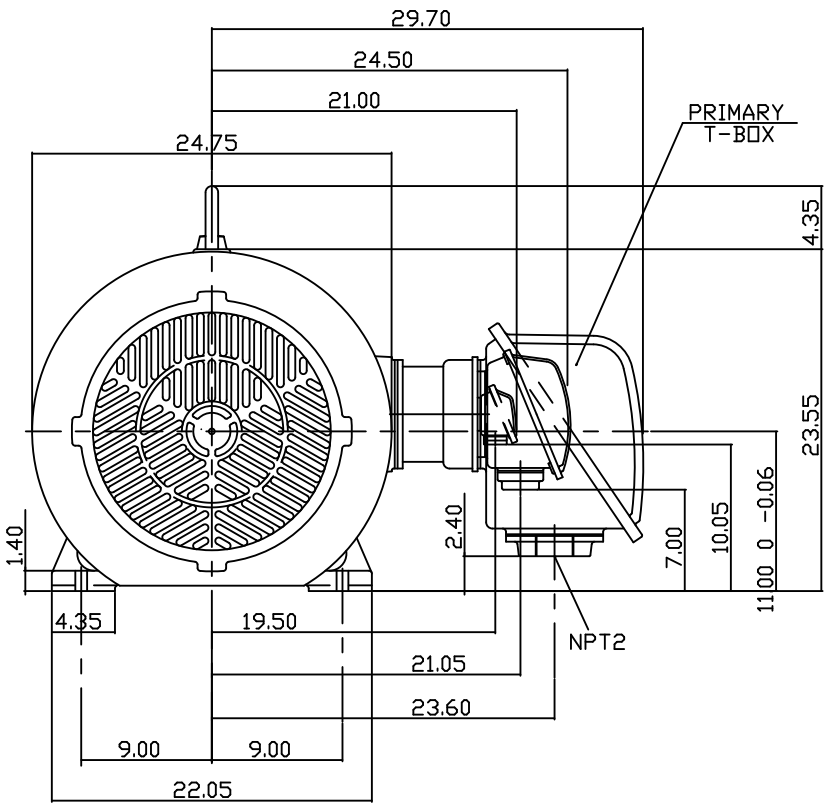

- NOTE:
1. DIMENSIONS IN INCH
 2. FRAME NO. 445TS
 3. F CLASS INSULATION, S.F.1.15
 4. FOR DIRECT FLEXIBLE COUPLING
 5. WITH WINDING RTD & SPACE HEATER
 6. ENCLOSURE: IP54
 7. BEARING SIZE DRIVE END: 6314C3
NON-DRIVE END: 6314C3
 8. APPROX. WEIGHT: 1680 LBS

TW-56C

DWN.	C. COOK	09-20-2013

DATE: MAY 13, 2013	OUTLINE DIMENSIONS
CATALOG # KG1252	3-PHASE INDUCTION MOTOR
TEC Westinghouse	
DWG NO. 3B040C096	REV: 00