

Product Information Packet

January 13, 2017

Data shown is for the current revision model #. Ensure your nameplate model # matches.

Model Number:	5KS284DAE7005B
Catalog Number:	V4601
Instruction Manual:	GEK-95353
Connection Diagram:	GEM2034E-FIG3
Outline Drawing:	4002B5828NMP5212

Accessory Connection Diagrams			
Bearing Thermocouple:	None	Heater:	3027JE-1C
RTD:	None	Thermistor:	None
Thermostat:	None	Winding Thermocouple:	None
Bearing RTD:	None		

Table of Contents

Specification	01
Performance Characteristics	02
Outline Drawing	03
Connection Drawing(s)	04
Spare parts	05



Marks:

MODEL NUMBER:	5KS284DAE7005B	Estimated Weight:	420 Lbs
Outline Drawing:	4002B5828NMP5212	Time Rating:	CONT
Connection Diagram:	GEM2034E-FIG3	Enclosure:	WPI
Instruction Book:	GEK-95353	Encl Construction:	OPEN
Design Code:	28BD3091A	Ambient Max(°C):	40
Type:	KS	Alt Ambient Max(°C):	--
Frame:	L284TP12	Insulation Class:	H
Phases:	3	NEMA Design:	B
Poles:	6	Nominal Efficiency:	91.7 %
Output Power:	15HP 11.1KW	Guaranteed Efficiency:	90.2
RPM:	1185	3/4 Load Efficiency:	92.8
Voltage:	230/460	KVA Code:	G
Hertz:	60	Max KVAR:	6.6
Amps - FL:	39.6/19.8	Power Factor:	77.5
Service Factor:	1.15	Bearing - DE:	7310
Alt Service Factor:	--	Bearing - ODE:	6210-2ZC3

Enclosure is Weather Protected One

Stamped Nameplate Notes:

PREMIUM EFFICIENT MOTOR
 NEMA ENCL WPI AND CSA ENCL DP
 ROT CCW FACING ODE LEAD/PH SEQUENCE 1-2-3/1-2-3
 HTR LDS HE1-HE2 115V 60W
 INVERTER DUTY PER NEMA MG1 PART 31
 ALTERNATE RATING FOR PWM CONTROL:
 1.0 SF VAR TORQUE RANGE 30-60 HZ
 SUITABLE FOR 10HP, 190/380V,
 50 HZ WITH 33.4/16.7AMPS AND 990 RPM AT 1.0 SF

Additional Information:

6P - TP EXTN
 C/BOX 137 CU IN-1.50 NPT
 AUX LEADS EXIT WITH MOTOR LEADS
 RCF 5000 CPM, STATIC DEFLECTION .0014 INCHES &
 CENTER OF GRAVITY 12.00 INCHES
 HOLLOW SHAFT HIGH THRUST
 OIL RESISTANT SLEEVING ON LEADS
 BEARING LIFE 8760 HOURS AT 3379 LB THRUST
 BALL TYPE COUPLING
 COUPLING WILL BE ORDERED SEPARATELY
 DP STOCK 10/24/2016
 ENGINEERED BY: BALASUBRAMANIANH/BILURP

Performance Characteristics

1st Winding 1st Connection

Design: 28BD3091A

Marks:

LOAD %	125.0	115.0	100.0	75.0	50.0	25.0	0.0
% EFF	91.44	91.85	92.55	92.79	92.31	88.71	0.00
% PF	80.1	79.31	77.44	71.68	60.18	38.39	4.13
AMPS	23.96	22.16	19.6	15.83	12.64	10.31	9.27

TORQ(FL)#FT	66.53	TORQ(LR)%FL	156.15	TORQ(BD)%FL	269.85
AMPS(LR)	109.12	PF AT START	0.36		

This motor is capable of two cold or one hot start with a maximum connected load inertia of 999 Lb-Ft Sq (42.06 Kg-meter Sq)at 100% voltage, where the load torque varies with the square of the speed. Acceleration time with maximum inertia and the above load type is 45 seconds. Safe stall time at 100% voltage is 100 seconds cold, 76 seconds hot. Rotor inertia is 5.18 Lb-Ft Sq (0.22 Kg-meter Sq).

Open Circuit A-C:	0.388	Short Circuit D-C:	0.014
Short Circuit A-C:	0.029	X/R Ratio:	5.223
Stator Slots:	54	Rotor Slots:	42

Speed Torque Current Curve (First Connection, First Speed)

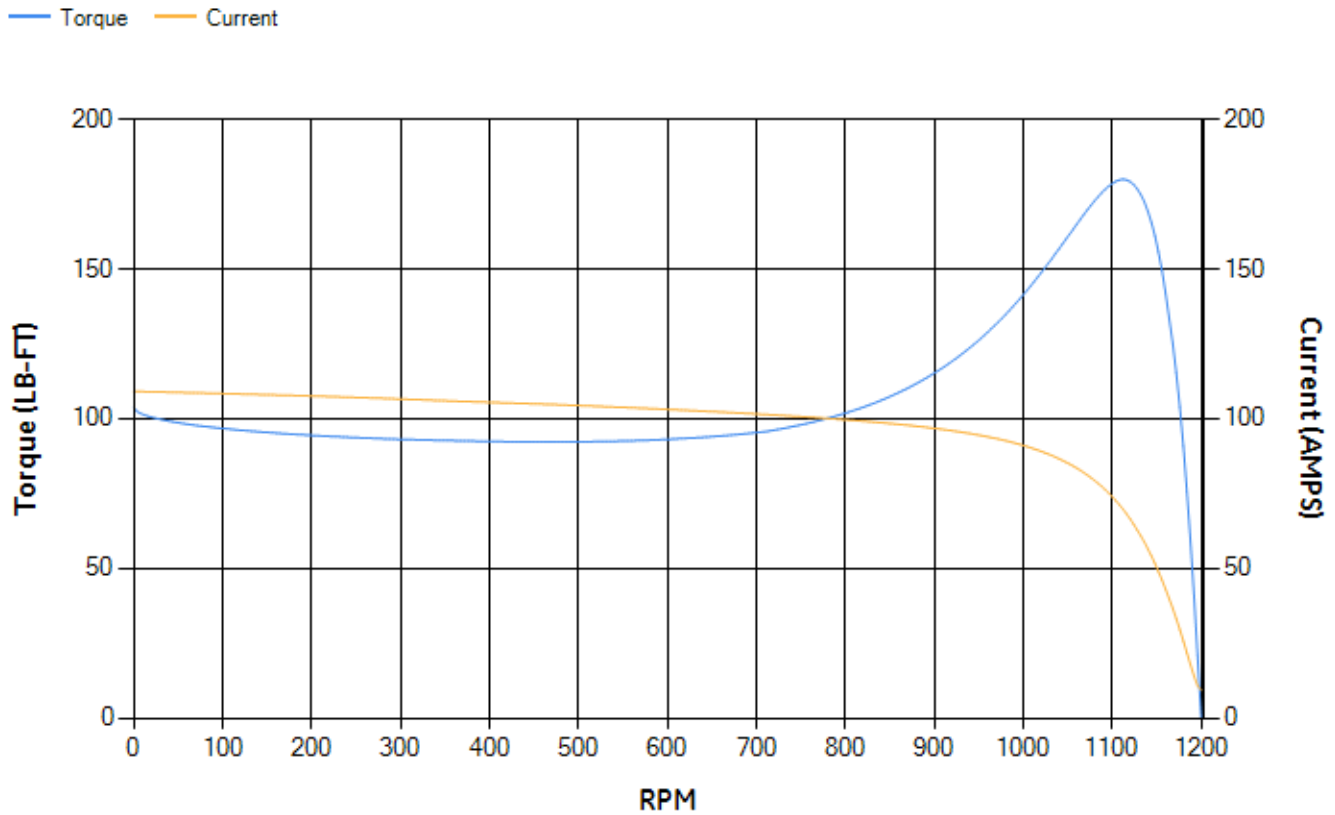

Marks:

Connection Diagram
GEM2034E-FIG3

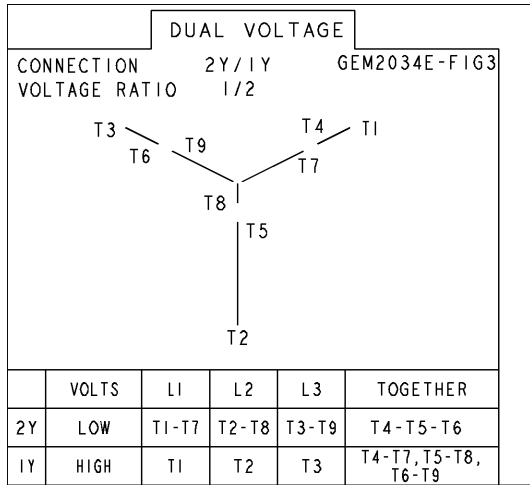

Heater Connection
3027JE-1C



End shield Assembly		
Part Description	DE Side Part#	ODE Side Part#
End Shield	128D6225PA1	128D6228PA1
Bearing	235A2508ET01	235A2508AK01
Slinger/Inproseal	235A2300FL2	

Fan & Fan Cover Assembly	
Part Description	Part#
Fan	
Fan Cover	

Conduit & Accessories Box Assembly	
Part Description	Part#
Conduit Box	4002B5728PA-G01

Mechanical Accessories	
Part Description	Part#
Brake	
Tachometer	