

035607

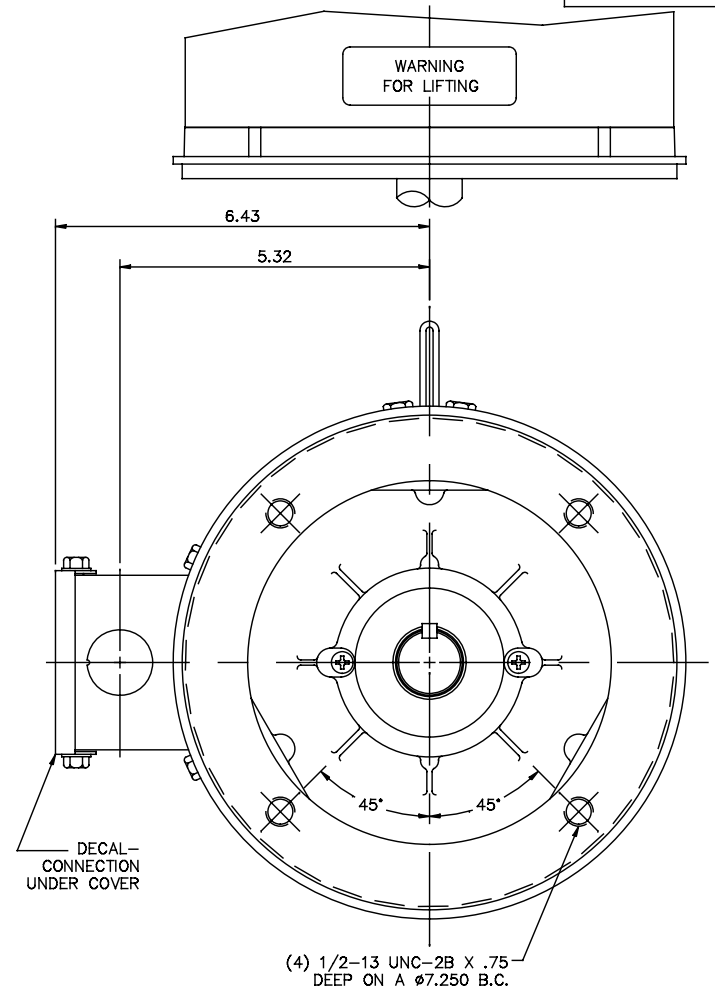
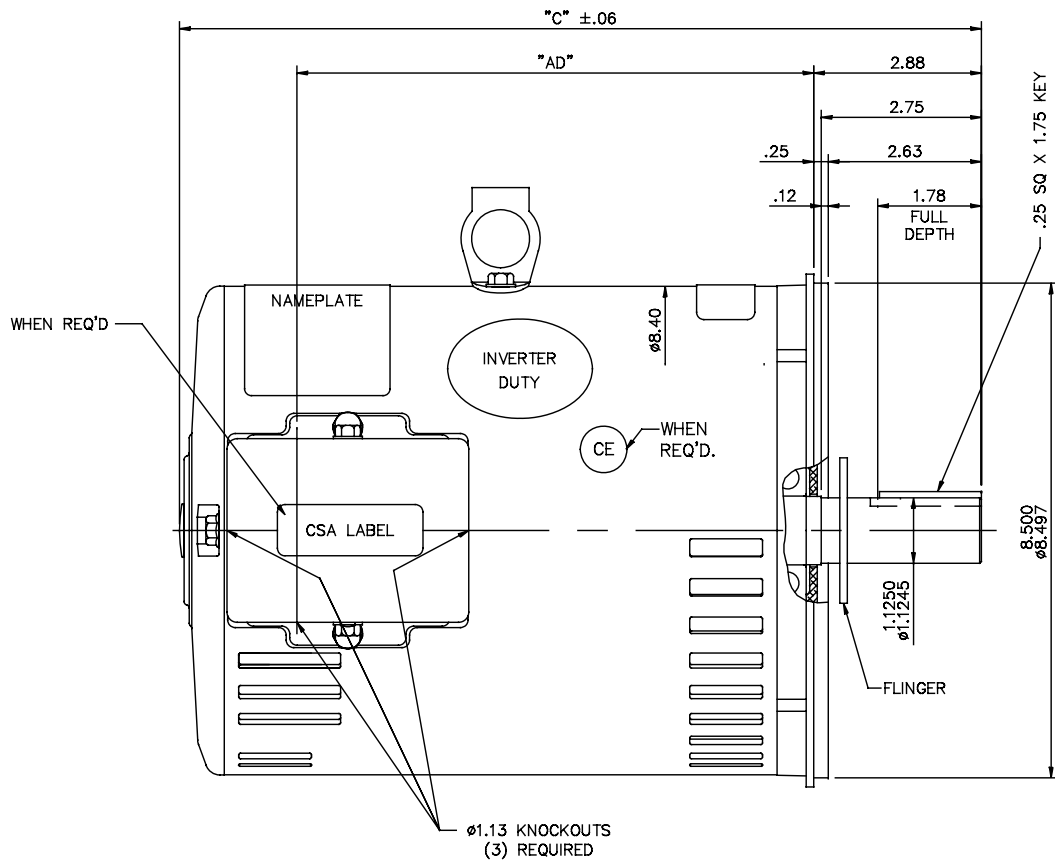

GASKETS THROUGHOUT

MAXIMUM FACE RUNOUT TO BE .004 T.I.R.  
 MAXIMUM PILOT ECCENTRICITY TO BE .004 T.I.R.  
 PERMISSIBLE SHAFT RUNOUT TO BE .002 T.I.R.

| DASH NO. | "C"   | "AD"  |
|----------|-------|-------|
| 800      | 12.28 | 7.38  |
| 850      | 12.78 | 7.88  |
| 900      | 13.28 | 8.38  |
| 950      | 13.78 | 8.88  |
| 1000     | 14.28 | 9.38  |
| 1050     | 14.78 | 9.88  |
| 1100     | 15.28 | 10.38 |
| 1150     | 15.78 | 10.88 |

| NO. | REVISION                           | BY & DATE     | CHK | ANG   | ±1/2"  | TOLERANCES UNLESS SPECIFIED |        |
|-----|------------------------------------|---------------|-----|-------|--------|-----------------------------|--------|
|     |                                    |               |     |       |        | DEC.                        | INCHES |
| 02  | CSA LABEL ADDED                    | PVR 06/24/15  | GR  | .XXX  | ±.005  |                             |        |
| 01  | ADDED -800 LENGTH PER ISSAC09-3353 | SSK 8/17/2009 |     | .XXXX | ±.0005 |                             |        |
|     |                                    |               |     |       |        |                             |        |
|     |                                    |               |     |       |        |                             |        |
|     |                                    |               |     |       |        |                             |        |
|     |                                    |               |     |       |        |                             |        |
|     |                                    |               |     |       |        |                             |        |
|     |                                    |               |     |       |        |                             |        |
|     |                                    |               |     |       |        |                             |        |

|   |  |                      |
|---|--|----------------------|
| MARATHON ELECTRIC                                 |  | DRAWN KVN 01/02/2007 |
| TITLE OUTLINE - 180TC FRAME DRIP PROOF - "C" FACE |  | CHK                  |
| MATERIAL  |  | APPD                 |
| FINISH  |  | SCALE 1=2            |
| CAD FILE 035607                                   |  | REF 035593           |
| SIZE B  |  | FMF 182TDW8067       |
| DRAWING NO. 035607                                |  | PREV                 |
| REV. 02   |  |                      |

THIS DRAWING IN DESIGN AND DETAIL IS OUR PROPERTY AND MUST NOT BE USED EXCEPT IN CONNECTION WITH OUR WORK. ALL RIGHTS OF DESIGN AND INVENTION ARE RESERVED. THIS IS AN ELECTRONICALLY GENERATED DOCUMENT - DO NOT SCALE THIS PRINT.

RFP  
DIST NLV