

TYPE	OUTPUT		POLE	RATING	VOLTAGE	Hz	SYNSPEED
	HP.	KW.					
AEHH	150	111.9	2	CONT.	460	60	3600

TOTALLY ENCLOSED FAN-COOLED TYPE, SQUIRREL-CAGE ROTOR

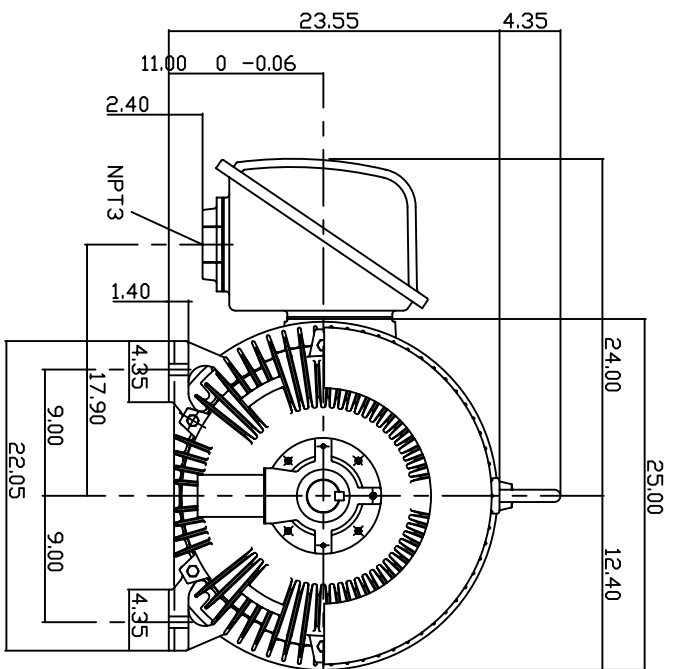
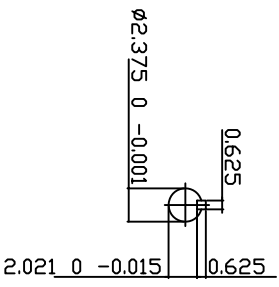
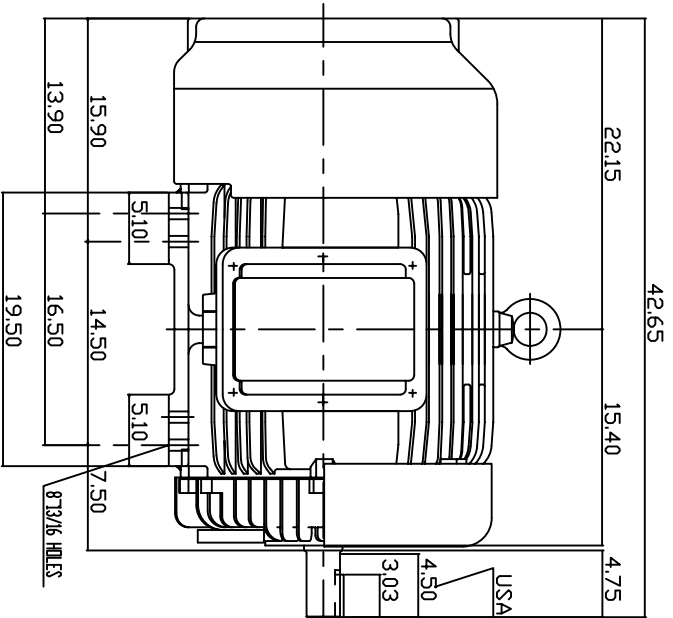

NOTE:

1. DIMENSIONS IN INCH
2. FRAME NO. 445TS
3. F CLASS INSULATION, S.F.115
4. FOR DIRECT FLEXIBLE COUPLING
5. ENCLOSURE: IP55
6. BEARING SIZE: DRIVE END: 6314C3
NON-DRIVE END: 6314C3
7. APPROX. WEIGHT: 1700 LBS
8. NON-SPARKING FAN.
9. NOISE: BELOW 83 DBA AT 1 METER, NO LOAD.

TW-56C

DWN.	T.H.Pan	FEB 18 2005
CHKD.	H.HUANG	FEB 18 2005
APPD.	C.WANG	FEB 18 2005

DATE: 06-20-05
 CATALOG #HH1502
 OUTLINE DIMENSIONS
 3-PHASE INDUCTION MOTOR



DWG NO. 3A040Y699
 REV. 00