

6 5 4 3 2 1

TYPE	OUTPUT		POLE	TIME RATING	VOLTAGE V	Hz	SYN.SPEED R.P.M
	HP.	kW.					
AEHH-8B	250	186.5	8	CONT.	460	60	900

TOTALLY ENCLOSED FAN-COOLED TYPE, SQUIRREL-CAGE ROTOR

PRIMARY T-BOX  
(NPT4)

D

C

B

A

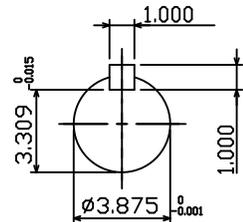
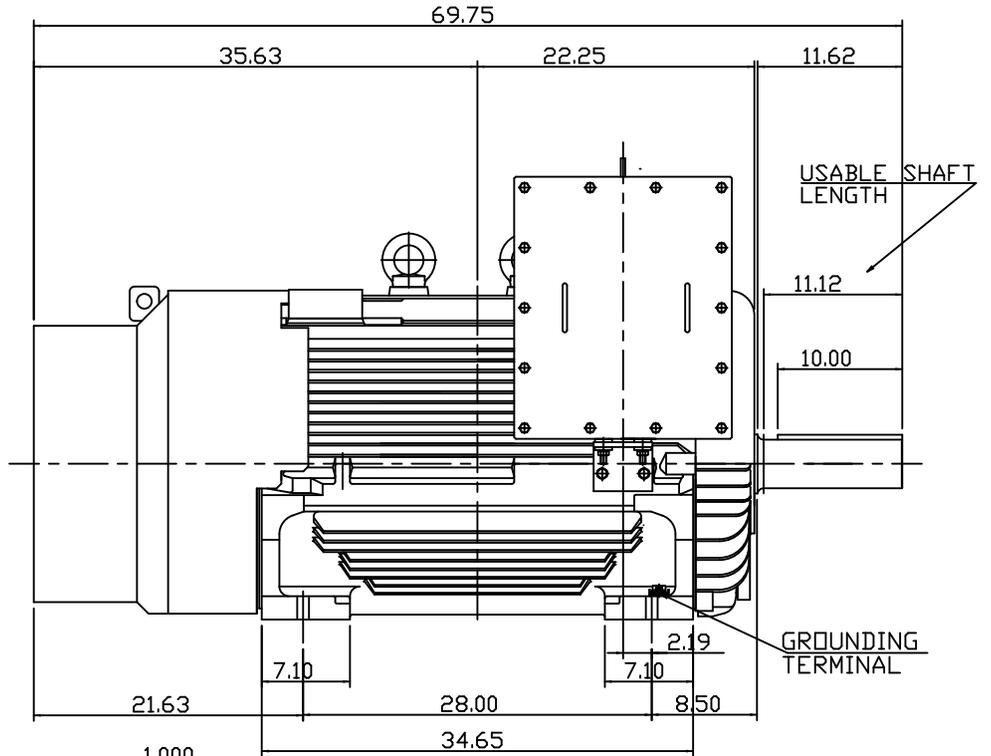
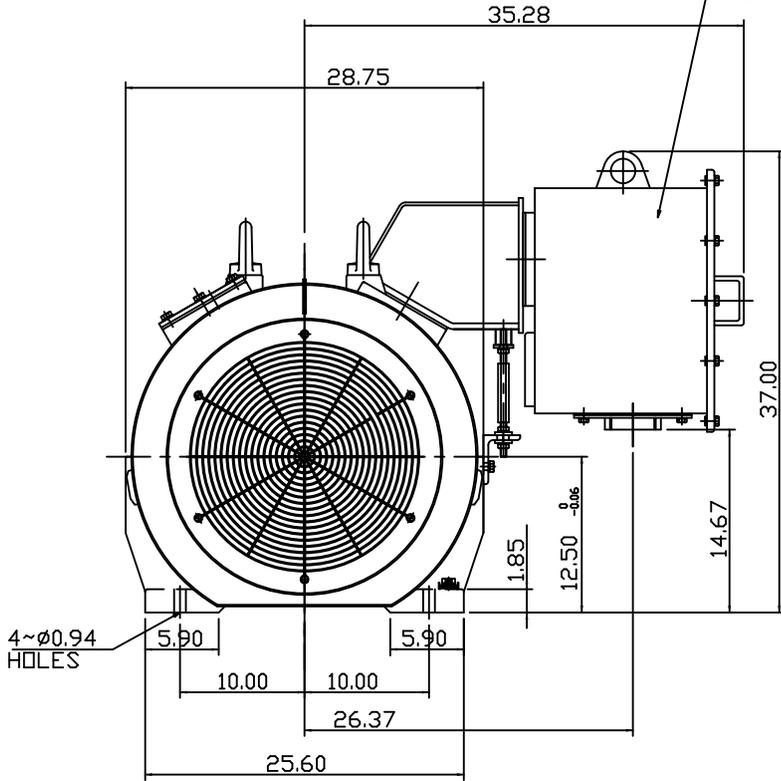

SHAFT END  
(ENLARGED VIEW)

NOTE:

1. DIMENSIONS IN inch
2. FRAME NO. 5009B
3. F CLASS INSULATION, S.F.1.15
4. FOR DIRECT FLEXIBLE COUPLING
5. ENCLOSURE: IP55
6. BEARING SIZE: DRIVE-END 6324C3  
OPP. DRIVE-END 6320C3
7. BOTH ENDS BEARING ARE INPRO SEAL
8. NON-SPARKING FAN
9. MOTOR APPROX. WEIGHT: 3500 lb

DATE MAR 25 2015

OUTLINE DIMENSIONS

3-PHASE INDUCTION MOTOR

DWN.	J.WU	APR-14-2014
CHKD.	W.CHENG	APR-28-2014
APPD.	C.SHIH	APR-28-2014

TEC Westinghouse

DWG NO. REV:00  
4B040C140

6 5 4 3 2 1