

Product Information Packet

January 12, 2017

Data shown is for the current revision model #. Ensure your nameplate model # matches.

Model Number:	5KS215CAA304B
Catalog Number:	E9616
Instruction Manual:	GEI-56128
Connection Diagram:	GEM2034E-FIG1
Outline Drawing:	4002B5821RAP5201

Accessory Connection Diagrams			
Bearing Thermocouple:	None	Heater:	None
RTD:	None	Thermistor:	None
Thermostat:	3027JE-2A	Winding Thermocouple:	None
Bearing RTD:	None		

Table of Contents	
Specification	01
Performance Characteristics	02
Outline Drawing	03
Connection Drawing(s)	04



Marks:

MODEL NUMBER:	5KS215CAA304B	Estimated Weight:	220 Lbs
Outline Drawing:	4002B5821RAP5201	Time Rating:	CONT
Connection Diagram:	GEM2034E-FIG1	Enclosure:	TEFC
Instruction Book:	GEI-56128	Encl Construction:	XP
Design Code:	21BD3000B	Ambient Max(°C):	40
Type:	KS	Alt Ambient Max(°C):	--
Frame:	215T	Insulation Class:	F
Phases:	3	NEMA Design:	B
Poles:	6	Nominal Efficiency:	89.5 %
Output Power:	5HP 3.7KW	Guaranteed Efficiency:	87.5
RPM:	1170	3/4 Load Efficiency:	90.5
Voltage:	575	KVA Code:	J
Hertz:	60	Max KVAR:	2.2
Amps - FL:	5.5	Power Factor:	76.5
Service Factor:	1.00	Bearing - DE:	6208ZC3
Alt Service Factor:	--	Bearing - ODE:	6208ZC3

Enclosure is Totally Enclosed Fan-Cooled

Stamped Nameplate Notes:

EXPLOSION PROOF MOTOR
TEMP CODE T3C
THERMOSTAT LEADS TB1-TB2
STAMP NP249A5571AC "CL I (C & D) CL II (F & G)"

Additional Information:

6P - T EXTN
STANDARD FLOOR MOUNT
C/BOX 26 CU IN-1.00 NPT
F1 CONDUIT BOX MOUNTING
AUX LEADS EXIT WITH MOTOR LEADS
CL I C & D CL II F & G EXPLOSION PROOF MOTOR

Performance Characteristics

1st Winding 1st Connection

Design: 21BD300B

Marks:

LOAD %	125.0	115.0	100.0	75.0	50.0	25.0	0.0
% EFF	88.1	88.79	89.84	90.48	90.15	86.04	0.00
% PF	79.06	78.37	76.63	71.08	59.9	38.72	5.07
AMPS	6.72	6.19	5.44	4.37	3.47	2.81	2.49

TORQ(FL)#FT	22.4	TORQ(LR)%FL	191.85	TORQ(BD)%FL	289.99
AMPS(LR)	35.04	PF AT START	0.46		

This motor is capable of two cold or one hot start with a maximum connected load inertia of 541 Lb-Ft Sq (22.78 Kg-meter Sq) at 100% voltage, where the load torque varies with the square of the speed. Acceleration time with maximum inertia and the above load type is 51 seconds. Safe stall time at 100% voltage is 114 seconds cold, 82 seconds hot. Rotor inertia is 0.91 Lb-Ft Sq (0.04 Kg-meter Sq).

Open Circuit A-C:	0.237	Short Circuit D-C:	0.009
Short Circuit A-C:	0.014	X/R Ratio:	3.578
Stator Slots:	36	Rotor Slots:	44

Speed Torque Current Curve (First Connection, First Speed)

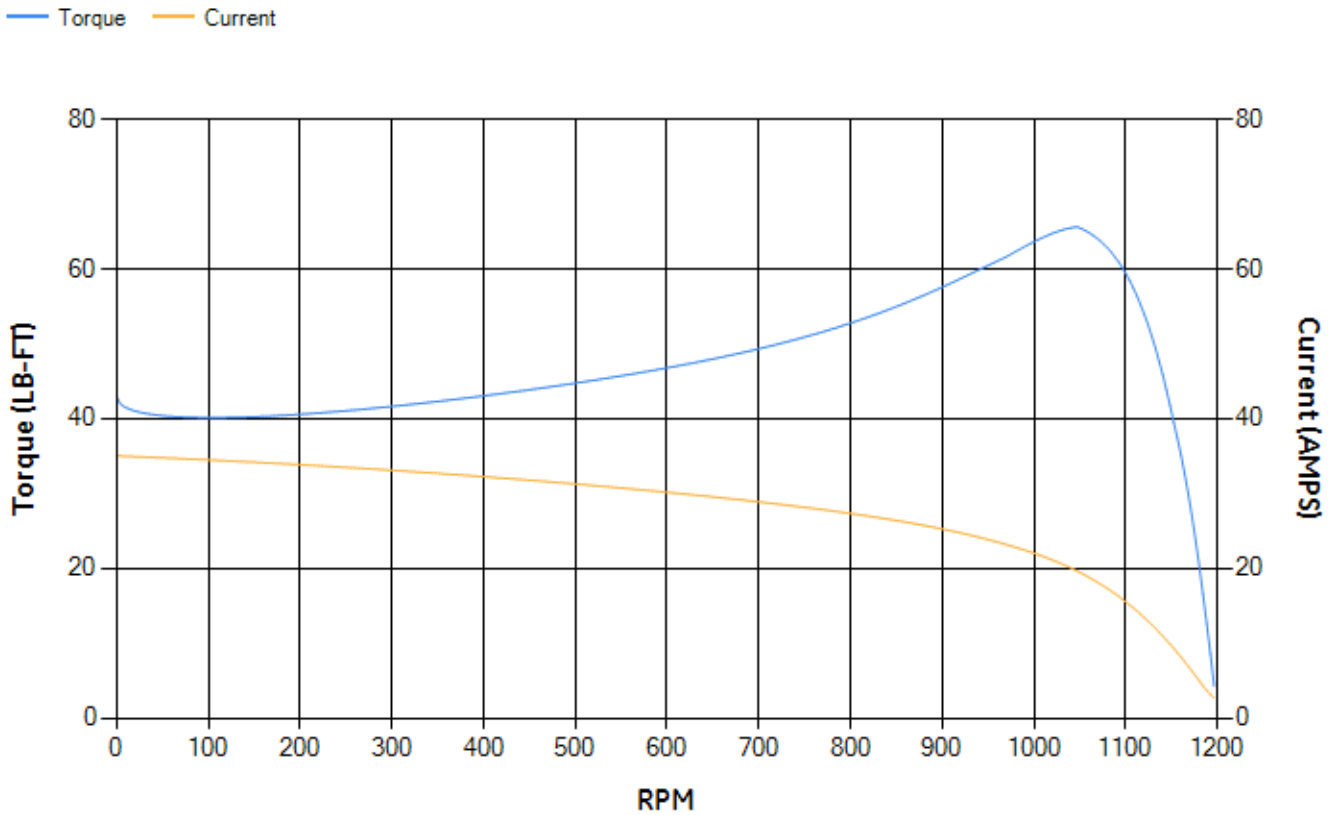

Marks:

NOTE 1: CONDUIT BOX MAY BE ASSEMBLED WITH ENTRANCE UP, DOWN OR TO EITHER SIDE.
 NOTE 2: F1 ASSEMBLY AS SHOWN. F2 ASSEMBLY CONDUIT BOX ON OPPOSITE SIDE FROM SHOWN LOCATION.
 NOTE 3: MOUNTING SURFACES TO BE SQUARE AND CONCENTRIC WITH SHAFT WITHIN .004 T.I.R.
 NOTE 4: SHAFT RUNOUT NOT TO EXCEED .002 T.I.R.

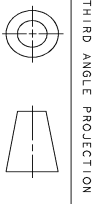
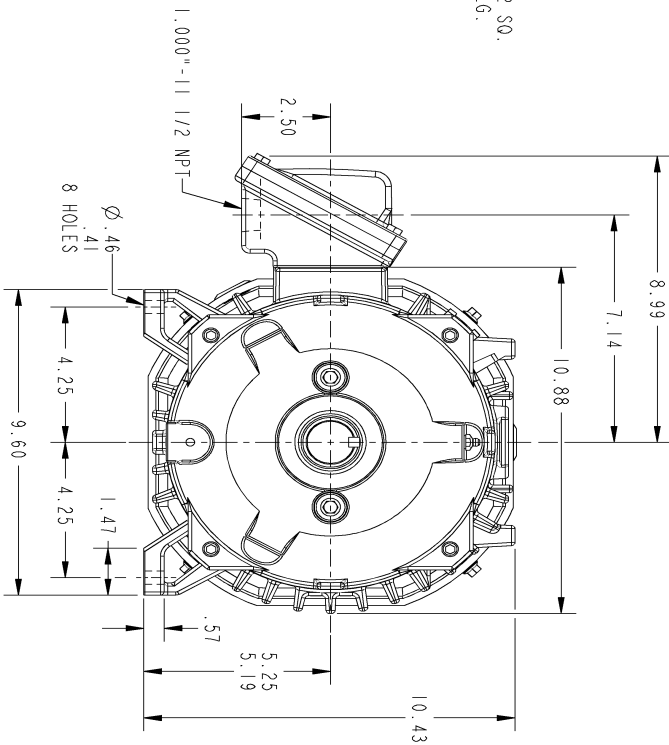
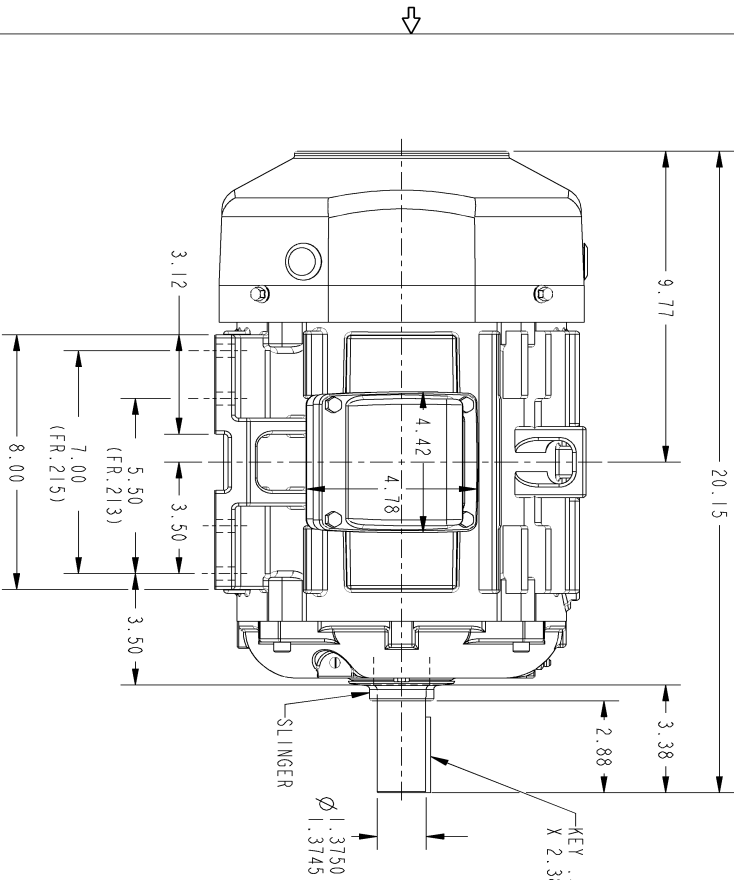

THIRD ANGLE PROJECTION

SIZE B DRAWING NO. 4002B5821RAP5201

SH 1 REV 1

REVISIONS

REV.	DESCRIPTION	DATE	APPROVED
1	ISAC#14-0486	06/17/14	KARTHIK

SIGNATURES	DATE
DRMAN BHARTHI	06/20/03
CHECKED ANAND	06/20/03
ENGRS BHARTHI	06/20/03
ISSUED	
APPLIED PRACTICES	

GE Industrial Systems
GENERAL ELECTRIC COMPANY
 Fort Wayne, Indiana

INDUCTION MOTOR OUTLINE
 STANDARD CONSTRUCTION
 FME: FR20T TFC EXPLOSION PROOF 26 CU IN. C/BOX
 SIZE DRAWING 4002B5821RAP5201 REV. 1
 SCALE: 0.300 REF. NO.: 4002B5821RAP201 SHEET 0F 1

DISTRIBUTION: PMP-1BK15

Marks:

Connection Diagram
GEM2034E-FIG1

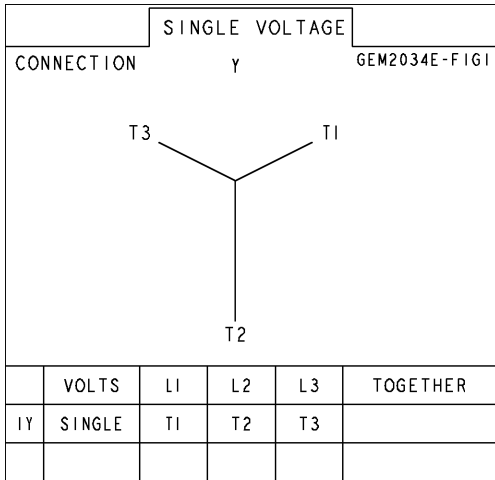

Thermostat Connection
3027JE-2A

