

NOTE:
LIFTING RINGS
(2) 180° APART
FOR MOTOR
LIFTING ONLY

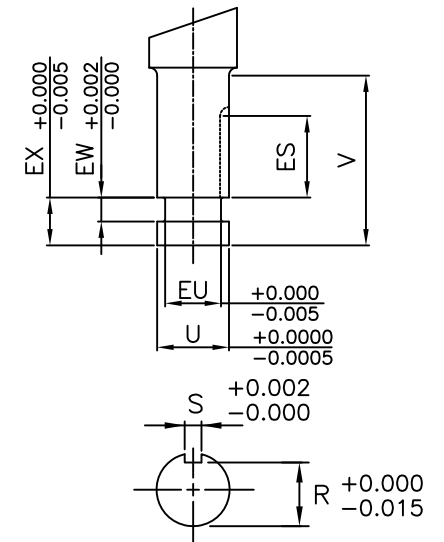
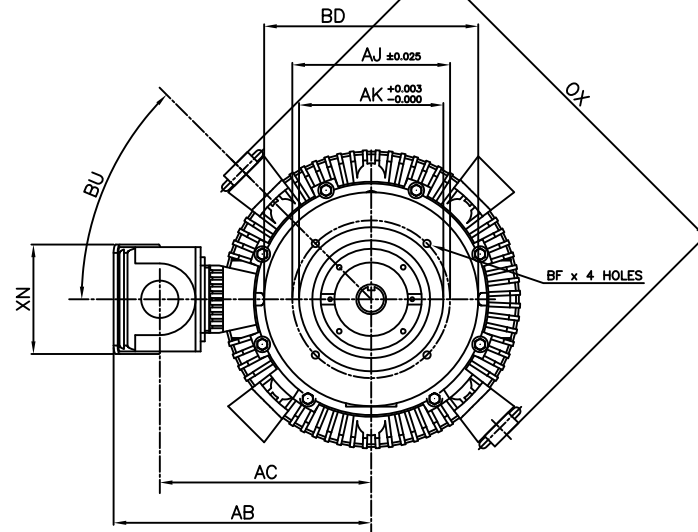
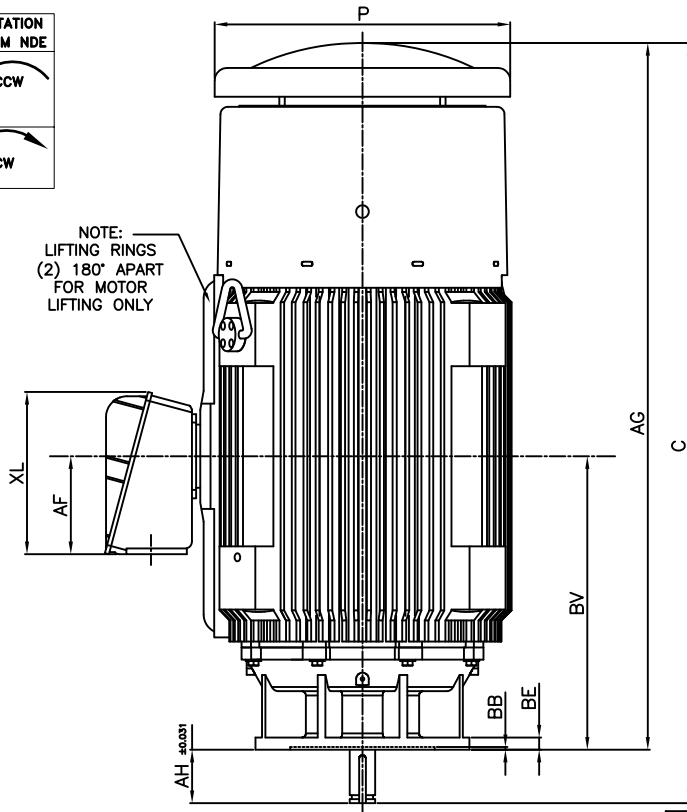

- NOTES:
1. DIMENSION V REPRESENTS LENGTH OF STRAIGHT PART OF SHAFT
 2. MAIN CONDUIT BOX MAY BE ROTATED IN 90° INCREMENTS
 3. KEY DIMENSIONS EQUAL S x S x ES (MOTOR SUPPLIED WITH KEY)
 4. MOTOR WEIGHT SHOWN IS MAXIMUM HORSEPOWER IN FRAME
 5. STANDARD PRODUCT USE BI-DIRECTIONAL FAN. OPPOSITE ROTATION AVAILABLE ONLY BY CONNECTION CHANGE

UNITS: INCHES

FRAME SIZE	MOTOR DIMENSIONS				P-FLANGE DIMENSIONS							
	AG	C	P	OX	BU	BB	BE	BF	BD	BV	AK	AJ
N449HP20	66.1	71.1	27.7	35.9	45°	0.25	1.2	0.69	20.0	27.5	13.50	14.75
N449HP24	66.1	71.1	27.7	35.9	45°	0.25	1.2	0.69	24.0	27.5	13.50	14.75
N449LP20	66.1	71.1	27.7	35.9	45°	0.25	1.2	0.69	20.0	27.5	13.50	14.75
N449LP24	66.1	71.1	27.7	35.9	45°	0.25	1.2	0.69	24.0	27.5	13.50	14.75

POLE SPEED	HORSE POWER	SHAFT EXTENSION DIMENSIONS									
		AH	EU	U	V	R	S	ES	EW	EX	
2	250~350	4.50	1.75	2.125	4.50	1.845	0.500	3.03	0.375	0.75	
	350~300	4.50	1.75	2.125	4.50	1.845	0.500	3.03	0.375	0.75	
4	350	5.00	2.00	2.375	5.00	2.021	0.625	3.53	0.375	0.75	
	200	4.50	1.75	2.125	4.50	1.845	0.500	3.03	0.375	0.75	
6	250	5.00	2.00	2.375	5.00	2.021	0.625	3.53	0.375	0.75	
	300~350	5.00	2.25	2.625	5.00	2.275	0.625	3.53	0.375	0.75	
8	150	5.00	2.00	2.375	5.00	2.021	0.625	3.53	0.375	0.75	
	200~250	5.00	2.25	2.625	5.00	2.275	0.625	3.53	0.375	0.75	

CONDUIT BOX DIMENSIONS						MAXIMUM WEIGHT
AA(NPT)	AB	AC	AF	XL	XN	
3.00	24.1	19.8	9.2	15.2	10.3	3800 lbs.

FRAME SIZE	BEARINGS	
	LS	OS
2 POLE HP	6313C3	6315C3
2 POLE LP	6313C3	7315BEGAM x 2
4~8 POLE HP	6318C3	6315C3
4~8 POLE LP	6318C3	7315BEGAM x 2

CUSTOMER: _____ MOTOR MODEL NO.: _____

P.O. NO.: _____ HP: _____ VOLTAGE: _____ RPM(SYN.): _____ Hz: _____

FRAME SIZE: _____ PRODUCT TYPE: VERTICAL SOLID SHAFT ROUND BODY P-FLANGE

COMMENTS: _____

PER: _____ DATE: _____

TAG NO's.:

- STANDARD (NO AUX. BOXES)
- RTD AUX. BOX
- SPACE HEATER AUX. BOX
- BEARING RTD's

TOSHIBA RESERVES THE RIGHT TO MAKE CHANGES OF TECHNICAL IMPROVEMENT AND THE DATA MAY CHANGE WITHOUT NOTICE PRELIMINARY

DO NOT USE FOR CONSTRUCTION, INSTALLATION, OR APPLICATION PURPOSES UNLESS THE DRAWING IS MARKED AS CERTIFIED CERTIFIED

TOSHIBA

TOSHIBA INTERNATIONAL CORPORATION

TOTALLY-ENCLOSED FAN-COOLED
VERTICAL SOLID SHAFT ROUND BODY P-FLANGE
3 PHASE INDUCTION MOTOR
F1 ASSEMBLY

XT SERIES

VISIT OUR WEBSITE AT:
www.toshiba.com/ind