

TYPE	OUTPUT		POLE	TIME RATING	VOLTAGE V	Hz	SYN.SPEED R.P.M
	HP.	kW.					
AEEAGD	150	112	4	CONT.	230/460	60	1800

TOTALLY ENCLOSED FAN-COOLED TYPE, SQUIRREL-CAGE ROTOR

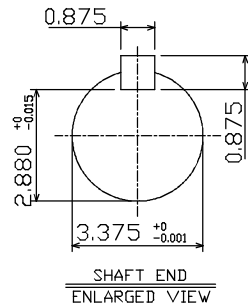
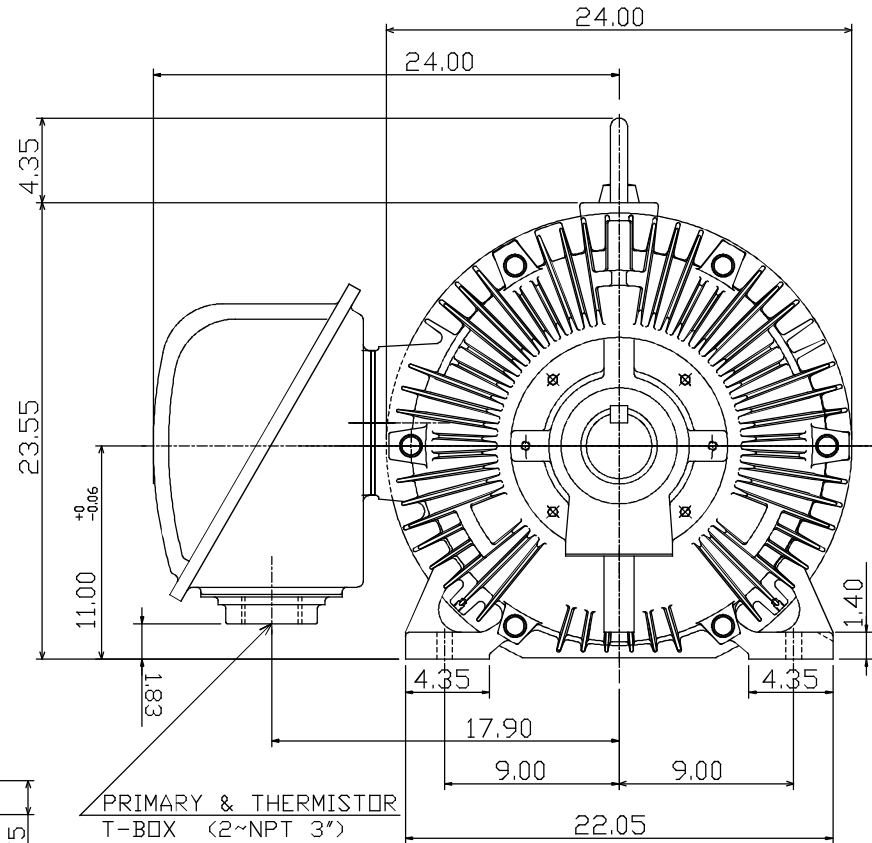
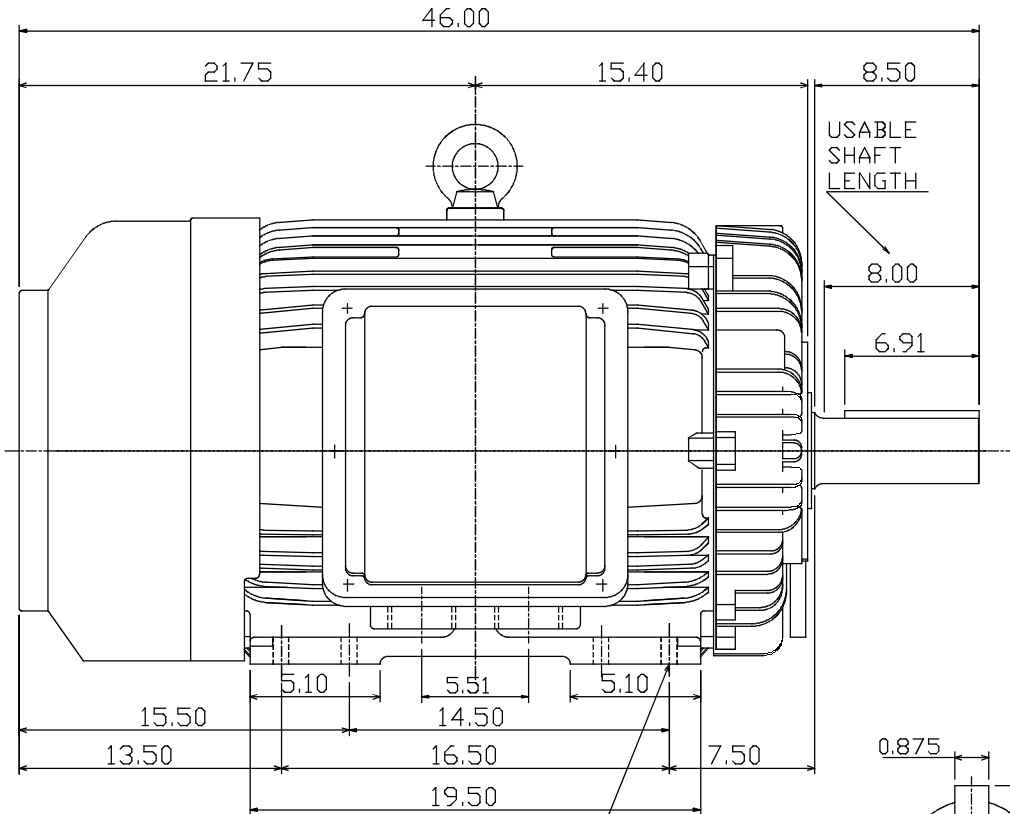

NOTE:

1. DIMENSIONS IN INCHES
2. FRAME NO. 445T
3. F CLASS INSULATION, S.F.115
4. FOR BELT SERVICE
5. BEARING SIZE: DRIVE END: NU318C3  
NON-DRIVE END: 6316C3
6. ENCLOSURE: IP55
7. WITH THERMISTOR: PTC 140°C 3PCS
8. SHAFT MATERIAL: SCM440 Q&T (AISI 4140 EQUIV)
9. CORROSION PROOF
10. MOTOR APPROX. WEIGHT: 1700 LBS

TW-56BC

DWN.	C. RAM	DEC 01 2015
DWN.	S.LEE	DEC•22•2006
CHKD.	S.LEE	DEC•22•2006
APPD.	C.WANG	DEC•22•2006

CATALOG NO.  
CD1504R

TEC Westinghouse

OUTLINE DIMENSIONS  
3-PHASE INDUCTION MOTOR

DWG NO. REV: 00  
3B040R345