

TYPE	OUTPUT		POLE	TIME RATING	VOLTAGE V	Hz	SYNSPEED R.P.M
	HP.	KW.					
ASHH	300	224	4	CDNT.	460	60	1800

DRIP PROOF TYPE, SQUIRREL-CAGE ROTOR

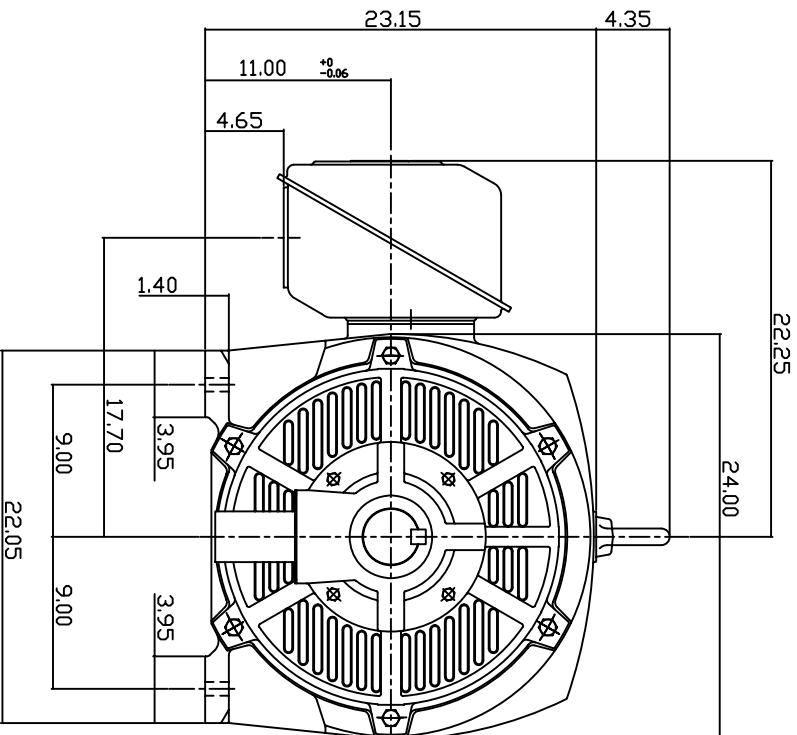
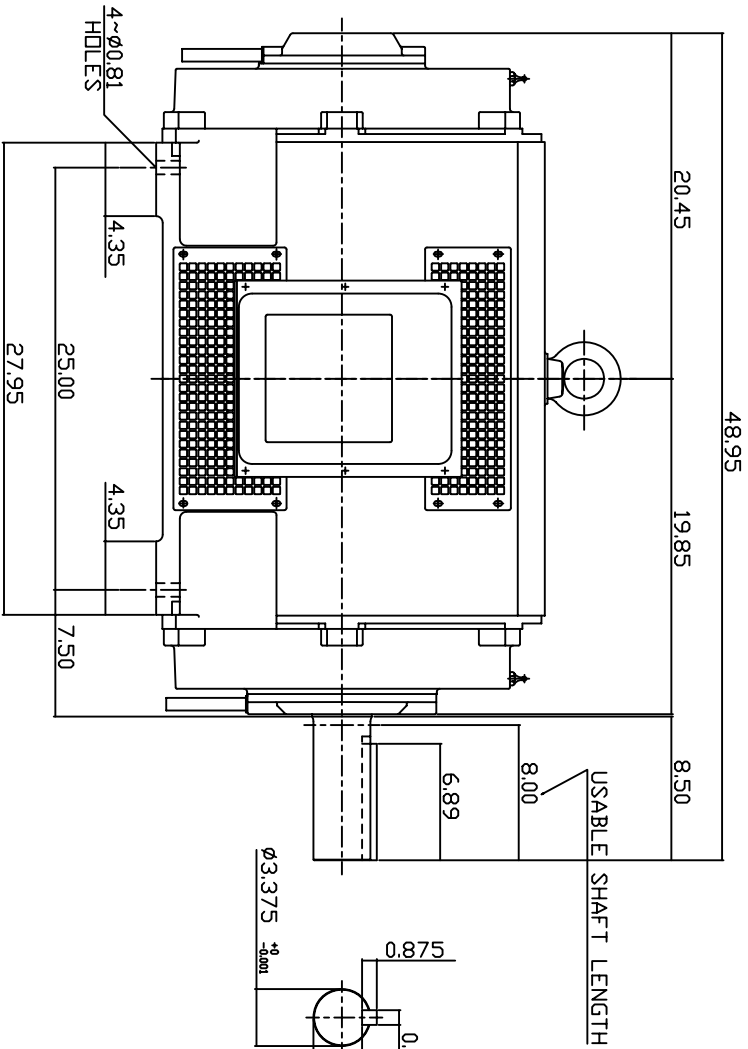

NOTE:

1. DIMENSIONS IN INCH.
2. FRAME NO. 449T
3. F CLASS INSULATION, S.F.1.15
4. FOR DIRECT FLEXIBLE COUPLING
5. BEARING SIZE: DRIVE END: 6320
NON-DRIVE END: 6318
6. MOTOR APPROX. WEIGHT: 1870 LBS

TB-56SC

DWN.	W.L.LIN	MAR. 26. 2003
CHKD.	W.L.LIN	MAR. 26. 2003
APPD.	C.WANG	MAR. 26. 2003

DATE	February 24, 2007	OUTLINE DIMENSIONS
CATALOG NO.	DHP3004	
3-PHASE INDUCTION MOTOR		DWG NO.
TEC Westinghouse		3A040T265-1
		REV: 00