

DATE  
APRIL 6, 2007  
CAT. #: XP0606C

OUTLINE DIMENSIONS  
3-PHASE INDUCTION MOTOR

MOTOR TYPE:  
AEHHXF  
FRAME NO. 404TC

Pole	HP	KW	Hz	VOLT	Syn. Speed r/min(rpm)
6	60	44.8	60	230/460	1200

Ins	Rating	Dimension in	Approx Weight	Bearings
F	CONT.	inches	1300 LBS	DE: 6317 NDE: 6313

Totally Enclosed Fan Cooled Type. Squirrel-cage Rotor.

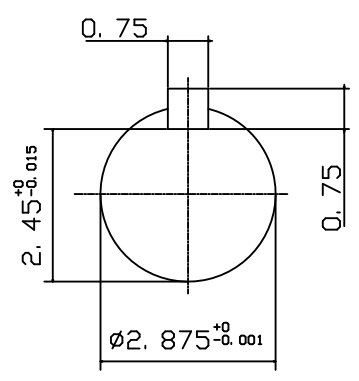
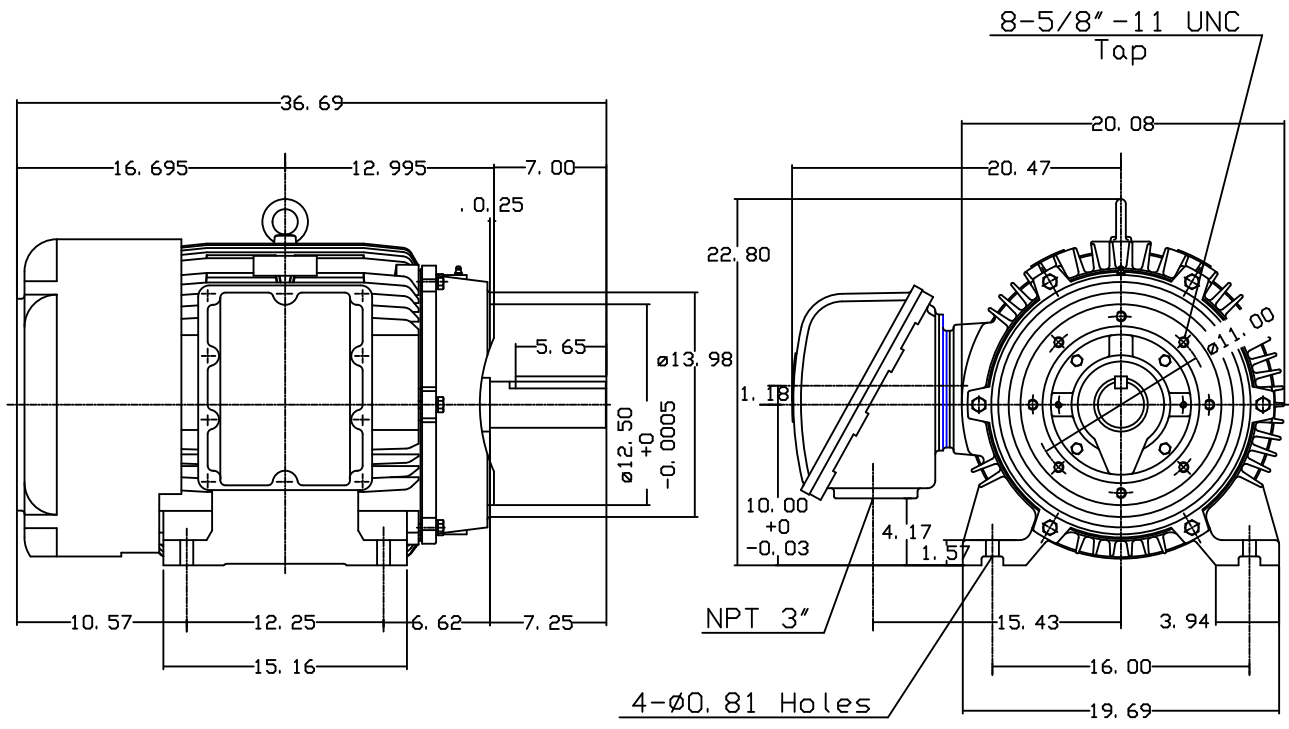

Note:  
1. Explosion proof:  
Class I Group D and  
Class II Group E, F, G.

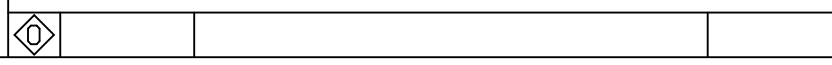

DWN.	J. H. LIANG	11-30-00
CHKD.	C. H. KAO	03-07-01
APPD.	Y. B. HUANG	03-07-01



DWG NO.  
31049M633100