

Product Information Packet

January 12, 2017

Data shown is for the current revision model #. Ensure your nameplate model # matches.

Model Number:	5KS513SAA144B
Catalog Number:	Q556
Instruction Manual:	GEI-56128
Connection Diagram:	GEM2034E-FIG2
Outline Drawing:	239C6C00GV

Accessory Connection Diagrams			
Bearing Thermocouple:	None	Heater:	3027JE-1C
RTD:	235A3027XY	Thermistor:	None
Thermostat:	None	Winding Thermocouple:	None
Bearing RTD:	235A3027NA		

Table of Contents	
Specification	01
Performance Characteristics	02
Outline Drawing	03
Connection Drawing(s)	04



Marks:

MODEL NUMBER:	5KS513SAA144B	Estimated Weight:	6685 Lbs
Outline Drawing:	239C6C00GV	Time Rating:	CONT
Connection Diagram:	GEM2034E-FIG2	Enclosure:	TEFC
Instruction Book:	GEI-56128	Encl Construction:	SD
Design Code:	50BD0118F	Ambient Max(°C):	40
Type:	KS	Alt Ambient Max(°C):	--
Frame:	5013ST	Insulation Class:	F
Phases:	3	NEMA Design:	--
Poles:	2	Nominal Efficiency:	95.8 %
Output Power:	600HP 444KW	Guaranteed Efficiency:	95.0
RPM:	3565	3/4 Load Efficiency:	96.1
Voltage:	2300/4000	KVA Code:	F
Hertz:	60	Max KVAR:	59.0
Amps - FL:	124.0/71.3	Power Factor:	94.5
Service Factor:	1.00	Bearing - DE:	6315ZC3
Alt Service Factor:	--	Bearing - ODE:	6315ZC3

Enclosure is Totally Enclosed Fan-Cooled

Stamped Nameplate Notes:

HTR LDS HE1-HE2 115V 350W
 ROT CW FACING ODE LEAD/PH SEQUENCE 1-2-3/1-2-3
 FOR DIRECT COUPLED LOAD ONLY

Additional Information:

2P - ST EXTN
 2500 CU IN - 2(4.00" NPT)
 100 OHM WINDING RTD LEADS TO AUX C/BOX OPP MAIN C/BOX
 SUGGESTED WINDING RTD SETTINGS
 ALARM 155C TRIP 165C
 115V HTR LDS TO AUX BOX OPP MAIN CONDUIT BOX
 SPACE HEATER CAUTION NAMEPLATE
 BEARING RTD 100 OHM ON BOTH ENDS
 SUGGESTED BEARING RTD SETTINGS
 ALARM 115C TRIP 125C
 NEMA TYPE GRD PAD
 F1 MOUNTING

Performance Characteristics

1st Winding 1st Connection

Design: 50BD0118F

Marks:

LOAD %	125.0	115.0	100.0	75.0	50.0	25.0	0.0
% EFF	95.04	95.32	95.88	96.09	96.1	94.64	0.00
% PF	93.67	94.04	94.42	94.47	93.02	84.84	7.65
AMPS	90.68	82.86	71.23	53.35	36.12	20.11	9.46

TORQ(FL)#FT	884.18	TORQ(LR)%FL	93.56	TORQ(BD)%FL	264.91
AMPS(LR)	443.68	PF AT START	0.17		

This motor is capable of two cold or one hot start with a maximum connected load inertia of 987 Lb-Ft Sq (41.55 Kg-meter Sq)at 100% voltage, where the load torque varies with the square of the speed. Acceleration time with maximum inertia and the above load type is 22 seconds. Safe stall time at 100% voltage is 57 seconds cold, 26 seconds hot. Rotor inertia is 147.71 Lb-Ft Sq (6.22 Kg-meter Sq).

Open Circuit A-C:	1.98	Short Circuit D-C:	0.038
Short Circuit A-C:	0.045	X/R Ratio:	14.357
Stator Slots:	48	Rotor Slots:	40

Speed Torque Current Curve (First Connection, First Speed)

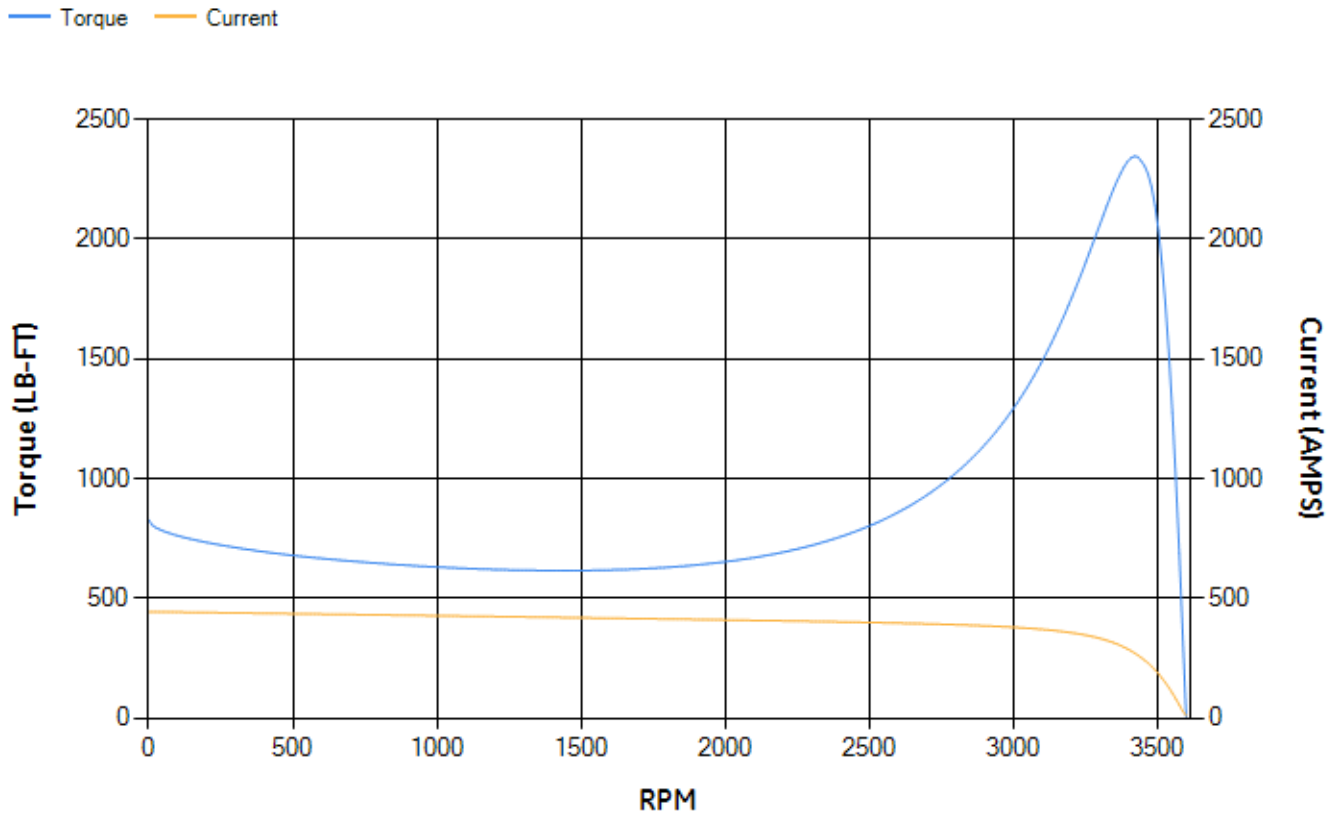

Marks:

Connection Diagram
GEM2034E-FIG2

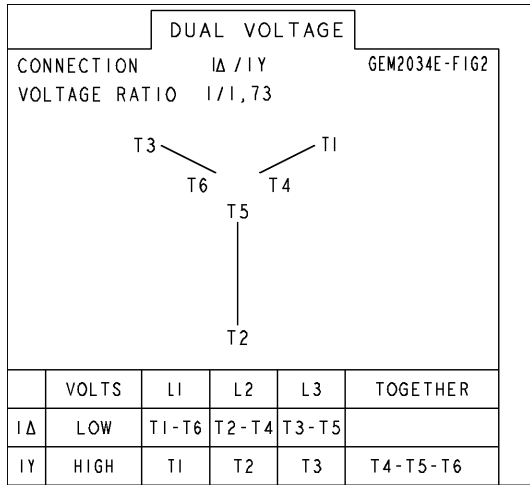

Heater Connection
3027JE-1C



GE PROPRIETARY INFORMATION

This document is the property of General Electric Company ("GE") and contains proprietary information of GE. This document is loaned on the express condition that neither it nor the information contained therein shall be disclosed to others without the express written consent of GE Industrial Systems, and that the information shall be used by the recipient only as approved expressly by GE Industrial Systems. This document shall be returned to GE upon its request. This document may be subject to certain restrictions under U.S. export control laws and regulations.

THIRD ANGLE PROJECTION

REVISIONS				
REV.	DESCRIPTION	DATE	APPROVED	
1	ISAAC# 15-0790 HARIKIRAN	07/28/15	DHEERAJ	
2	ISAAC# 16-0422 SAGAR K	05/04/2016	ADINARAYANA	

SHEET 2

REV 235A3027XY

SIZE DRAWING NO. A

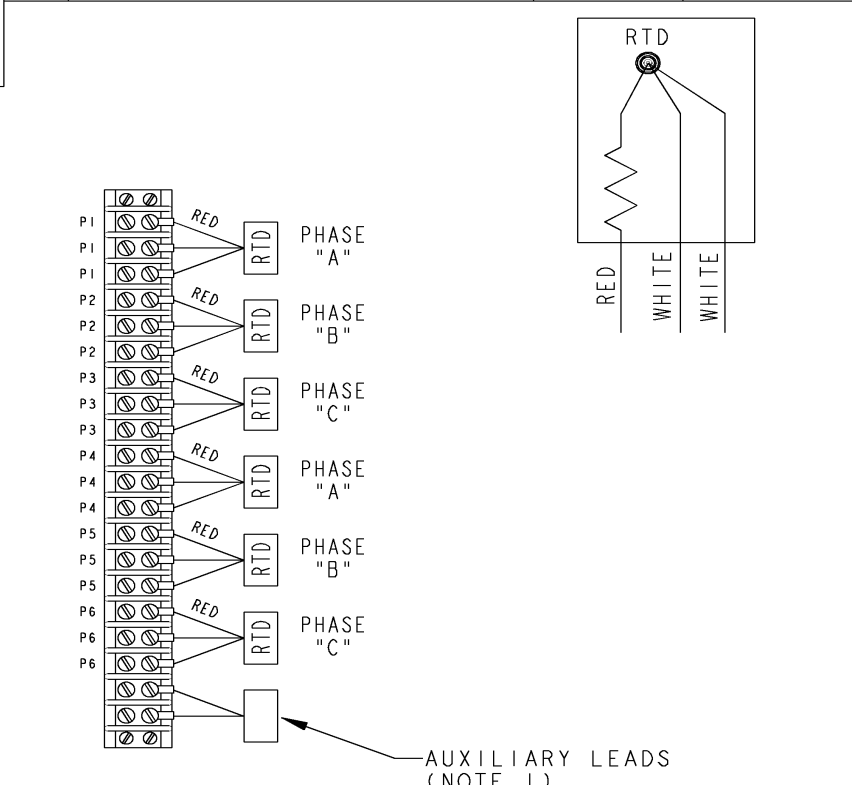

NOTE 1: AUXILIARY LEADS SHOWN MAY OR MAY NOT BE PROVIDED IN MOTOR.
 NOTE 2: SPARE RTDS (P7 & P8) FURNISHED IN CASE OF FAILURE IN OTHER RTDS (P1-P6). PHASE LOCATION WILL DEPEND UPON NUMBER OF POLES WINDING CONFIGURATION.

Part must conform to SI 900000 Sect. 4, Toxicity Procedure

FOR ADDITIONAL INFO REFER TO:	SIGNATURES	DATE
APPLIED PRACTICES	MODEL	
DIMENSIONS ARE IN INCHES	DETAIL VIVEK	06/26/15
TOLERANCE ON:	CHECKED KARTHIK	06/26/15
1 PL DECIMALS ± 0.1	ENGRG	
2 PL DECIMALS ± 0.02	MFG	
3 PL DECIMALS ± 0.005	QUALITY	
ANGLES ± 0.5	ISSUED VIVEK	06/26/15
FRACTIONS ±		
FINISH ✓	SOLID MODEL: MODEL NAME	

GE Motors GENERAL ELECTRIC COMPANY

TITLE **CONNECTION DIAGRAM**
WINDING RTD & AUXILIARY LEADS

SIZE DRAWING **A** **235A3027XY** REV **2**
 SCALE: N.T.S. REF:- 235A4594X SHEET 1 of 1

REV SH 1 1	THIRD ANGLE PROJECTION		REVISIONS			
			REV	DESCRIPTION	DATE	APPROVED
			1	ISAAC #12-1124	HARI	11/19/12

CONFIDENTIAL AND PROPRIETARY

This document is the property of General Electric Company and contains proprietary and confidential information of the Motor Business Group (MBG). The document is loaned on the express conditions that neither it nor the information contained therein shall be disclosed to others without the express consent of MBG and that the information shall be used by the recipient only as approved expressly by MBG. Also, the document shall be returned to MBG upon its request.

SIZE DWG NO 235A3027NA

BEARING RTDS

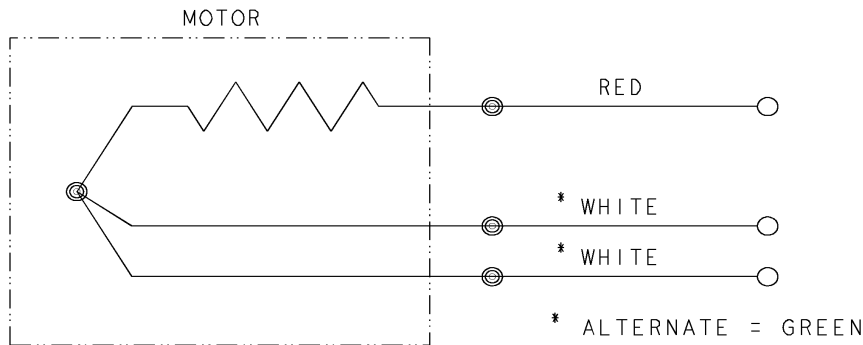

UNLESS OTHERWISE SPECIFIED DIMENSIONS ARE IN INCHES TOLERANCES ON: 2 PL DECIMALS ± 3 PL DECIMALS ± ANGLES ± FRACTIONS ± MATERIAL: APPLIED PRACTICES:	SIGNATURES	DATE	Fort Wayne, Indiana		
	DRAWN D.E. BAIR	12/16/92			
	CHECKED D.E. BAIR	12/16/92			
	ENGRG K. DESAI	12/16/92			
ISSUED D.E. BAIR	12/16/92				
CAD NO. F500:235A3027NA	SIZE A	FSCM NO	DWG NO 235A3027NA	SHEET 1 OF 1	
SCALE 1/1					

DISTR TO