

# Product Information Packet

November 9, 2016

Data shown is for the current revision model #. Ensure your nameplate model # matches.

<b>Model Number:</b>	<b>5KS184XAA200D1</b>
<b>Catalog Number:</b>	<b>M8910</b>
<b>Instruction Manual:</b>	GEI-56128
<b>Connection Diagram:</b>	GEM2034E-FIG1
<b>Outline Drawing:</b>	4002B5818PBP5311

Accessory Connection Diagrams			
<b>Bearing Thermocouple:</b>	None	<b>Heater:</b>	None
<b>RTD:</b>	None	<b>Thermistor:</b>	None
<b>Thermostat:</b>	None	<b>Winding Thermocouple:</b>	None
<b>Bearing RTD:</b>	None		

## Table of Contents

Specification	01
Performance Characteristics	02
Outline Drawing	03
Connection Drawing(s)	04
Spare parts	05



**Marks:**

<b>MODEL NUMBER:</b>	<b>5KS184XAA200D1</b>	<b>Estimated Weight:</b>	101 Lbs
<b>Outline Drawing:</b>	4002B5818PBP5311	<b>Time Rating:</b>	CONT
<b>Connection Diagram:</b>	GEM2034E-FIG1	<b>Enclosure:</b>	TEFC
<b>Instruction Book:</b>	GEI-56128	<b>Encl Construction:</b>	841
<b>Design Code:</b>	18BD1001A	<b>Ambient Max(°C):</b>	40
<b>Type:</b>	KS	<b>Alt Ambient Max(°C):</b>	--
<b>Frame:</b>	184TC	<b>Insulation Class:</b>	H
<b>Phases:</b>	3	<b>NEMA Design:</b>	B
<b>Poles:</b>	4	<b>Nominal Efficiency:</b>	89.5 %
<b>Output Power:</b>	5HP 3.7KW	<b>Guaranteed Efficiency:</b>	88.5
<b>RPM:</b>	1755	<b>3/4 Load Efficiency:</b>	90.4
<b>Voltage:</b>	460	<b>KVA Code:</b>	J
<b>Hertz:</b>	60	<b>Max KVAR:</b>	2.0
<b>Amps - FL:</b>	6.6	<b>Power Factor:</b>	79.5
<b>Service Factor:</b>	1.15	<b>Bearing - DE:</b>	6307ZC3
<b>Alt Service Factor:</b>	--	<b>Bearing - ODE:</b>	6206ZC3

**Enclosure is Totally Enclosed Fan-Cooled**

**Stamped Nameplate Notes:**

IEEE-STD-841-2009  
 DE BRG 35BC03JP30 ODE BRG 30BC02JP30  
 STAMP NP249A5564P051 AS BELOW:  
 MODEL:5KS184XAA200D1 S/N: XXX  
 CSA CERTIFIED CSA09.2216219 FOR EX NA IIC 200 C GC  
 CL1 ZONE2 AEXNAIIC 200C FOR CL1DIV2 GRP ABCD 200C  
 IN -25C <= AMB <= 40C, 1.0 SF ON SINE-WAVE PWR  
 SURF TEMP 200 C AT 1.15 SF ON SINE-WAVE PWR  
 OR 200 C VT OR 215 C CT OR 200 C CHP PWM CONTROL  
 ALTERNATE RATING FOR PWM CONTROL 1.0 SF 40 C AMB  
 VT 0-60 HZ, CT 6-60 HZ, CHP 60-90 HZ.

**Additional Information:**

4P - T EXTN  
 STANDARD FLOOR MOUNT  
 C/BOX 55 CU IN-1.00 NPT  
 F1 CONDUIT BOX MOUNTING  
 "C" FACE AT DE ENDSHIELD  
 PAINTED FRAME ID & SHAFT,  
 FAN COVER INSIDE & ODE E/S OUTSIDE  
 ROUTINE AND 5 POINT VIBRATION TESTS INCL IN C/BOX  
 INPRO SEAL BOTH ENDS  
 GROUND SCREW ON FRAME  
 SHAFT RUNOUT LIMIT .001" TIR  
 COPPER WASHER UNDER HEADS OF BEARING CAP BOLTS  
 APPLY TITE-SEAL (A50CD427A) ON BEARING CAP SCREWS, RABBETS,  
 AND PLUG THREADS

OIL RESISTANT SLEEVING ON LEADS

**Performance Characteristics**

1st Winding 1st Connection

**Design: 18BD1001A**

**Marks:**

LOAD %	125.0	115.0	100.0	75.0	50.0	25.0	0.0
% EFF	88.12	88.78	89.81	90.44	90.1	85.98	0.00
% PF	81.6	80.98	80.8	74.23	63.37	41.66	5.79
AMPS	8.14	7.49	6.45	5.23	4.1	3.27	2.74

<b>TORQ(FL)#FT</b>	14.97	<b>TORQ(LR)%FL</b>	228.66	<b>TORQ(BD)%FL</b>	298.67
<b>AMPS(LR)</b>	41.06	<b>PF AT START</b>	0.51		

This motor is capable of two cold or one hot start with a maximum connected load inertia of 183 Lb-Ft Sq (7.7 Kg-meter Sq) at 100% voltage, where the load torque varies with the square of the speed. Acceleration time with maximum inertia and the above load type is 36 seconds. Safe stall time at 100% voltage is 79 seconds cold, 51 seconds hot. Rotor inertia is 0.35 Lb-Ft Sq (0.01 Kg-meter Sq).

<b>Open Circuit A-C:</b>	0.237	<b>Short Circuit D-C:</b>	0.008
<b>Short Circuit A-C:</b>	0.012	<b>X/R Ratio:</b>	3.151
<b>Stator Slots:</b>	36	<b>Rotor Slots:</b>	28

**Speed Torque Current Curve (First Connection, First Speed)**

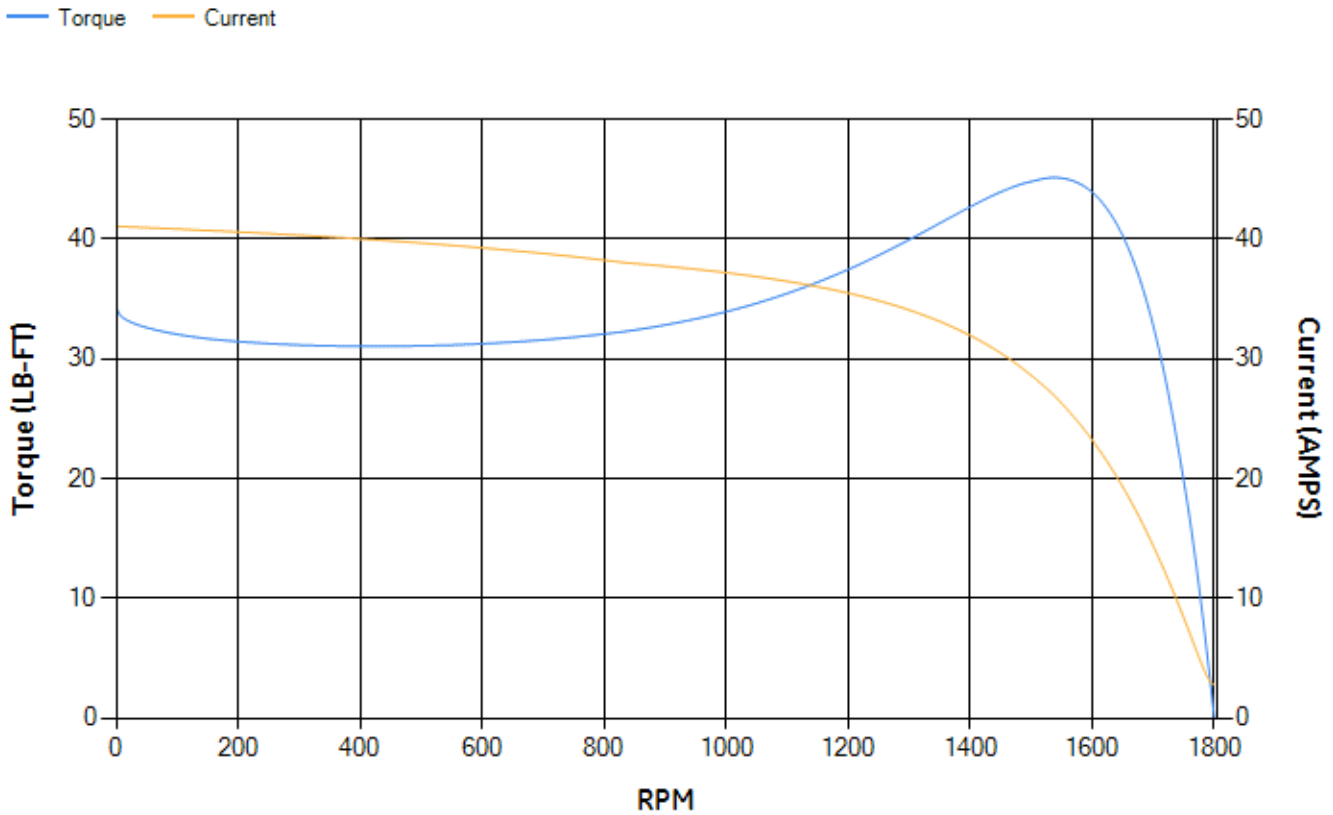

Marks:

NOTE 1: CONDUIT BOX MAY BE ASSEMBLED WITH ENTRANCE UP OR DOWN.  
 NOTE 2: F1 ASSEMBLY AS SHOWN. F2 ASSEMBLY CONDUIT BOX ON OPPOSITE SIDE FROM SHOWN LOCATION.  
 NOTE 3: MOUNTING SURFACES WILL BE SQUARE AND CONCENTRIC WITH SHAFT WITHIN .004 T.I.R.  
 NOTE 4: SHAFT RUNOUT WILL NOT EXCEED .001 T.I.R.  
 NOTE 5: ALL DIMENSIONS ARE IN INCHES, BRACKETED DIMENSIONS ARE IN METRIC (MILLIMETERS).

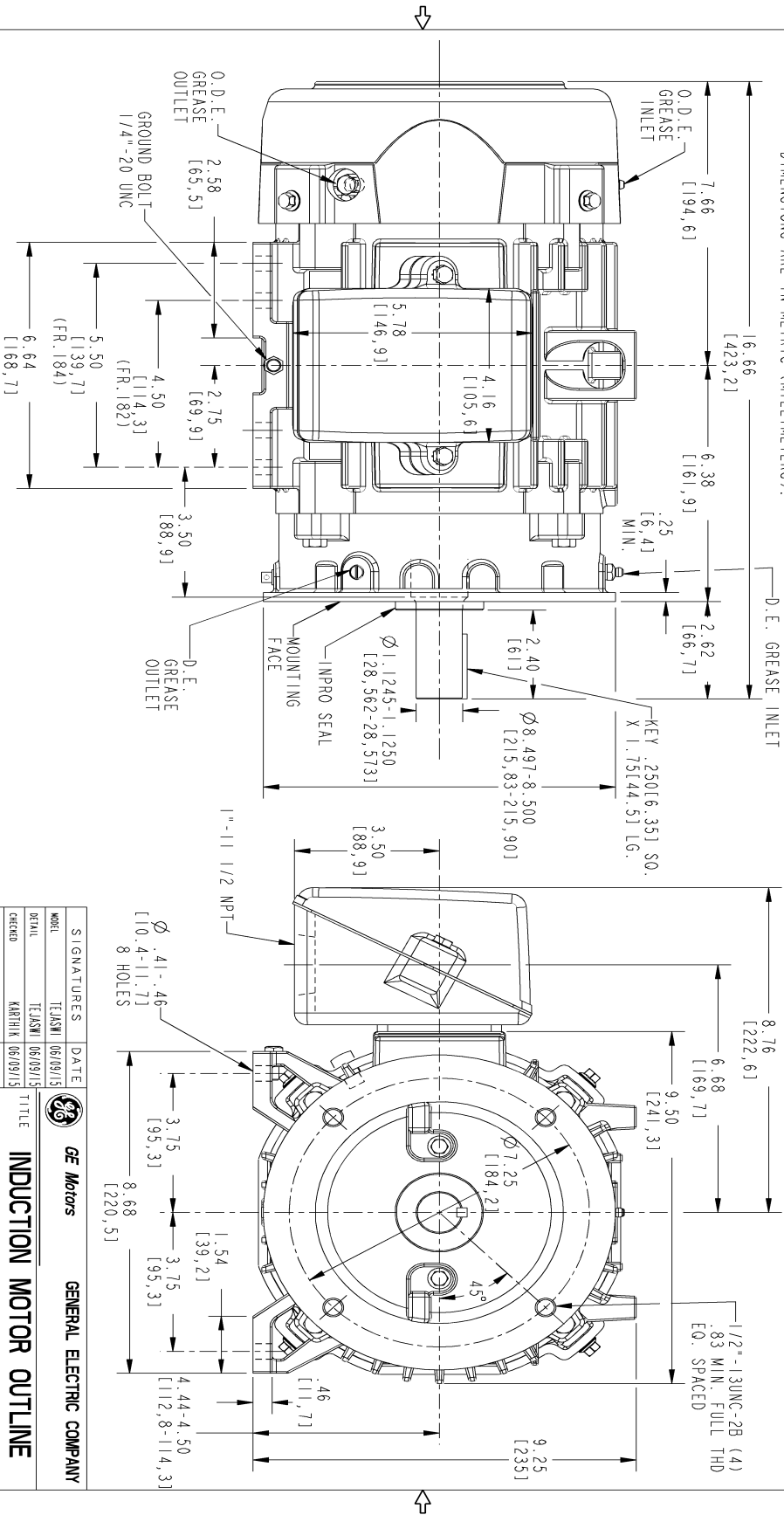

SIZE DRAWING NO. 4002B5818PBP5311 0

REV.	DESCRIPTION	DATE	APPROVED

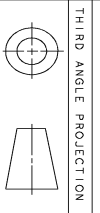

THIRD ANGLE PROJECTION

SIGNATURES	DATE	GE Motors	GENERAL ELECTRIC COMPANY
MODEL	TEJASNI 06/09/15		
DETAIL	TEJASNI 06/09/15		
CHECKED	KARTHIK 06/09/15		
ENGR	VENKAT 06/09/15		
QC			
QUALITY	TEJASNI 06/09/15		
ISSUED	B		
SOLD MODEL	4002B5818PBP5311		
SCALE: 0.400 REF. No. 4002B5818PBP5301			
TITLE			
INDUCTION MOTOR OUTLINE			
IEEE-841 SPEC. "C" FACE AT DE (850° RABBIT)			
FR182/184 TC TERC			
4002B5818PBP5311	REV		
0			
			SHEET 1 of 1

Marks:

**Connection Diagram**  
**GEM2034E-FIG1**

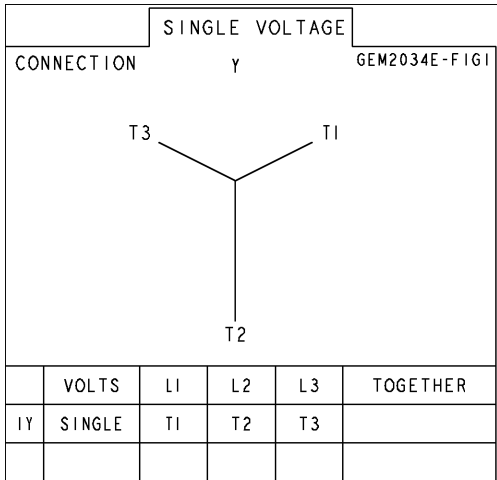

End shield Assembly		
Part Description	DE Side Part#	ODE Side Part#
End Shield	4004D5286PE1	4004D5281SG1
Bearing	235A2601AA01	235A2602AA01
Slinger/Inproseal	316A5384AJ1	4002B5914AG2

Fan & Fan Cover Assembly	
Part Description	Part#
Fan	4001A5914AM-G01
Fan Cover	4003C5786PA1

Conduit & Accessories Box Assembly	
Part Description	Part#
Conduit Box	4002B5721PA-G01

Mechanical Accessories	
Part Description	Part#
Brake	
Tachometer	