

TYPE	OUTPUT		POLE	TIME RATING	VOLTAGE V	Hz	SYN.SPEED R.P.M
	HP.	kW.					
AEHGTK	150	112	6	CONT.	2300/4160	60	1200

TOTALLY ENCLOSED FAN-COOLED TYPE, SQUIRREL-CAGE ROTOR

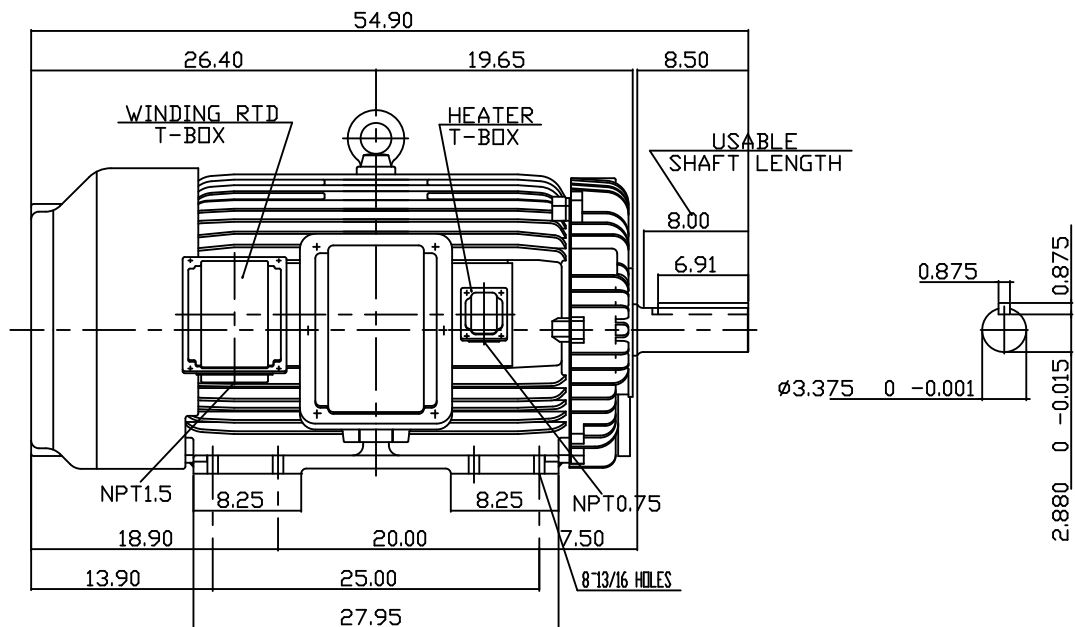
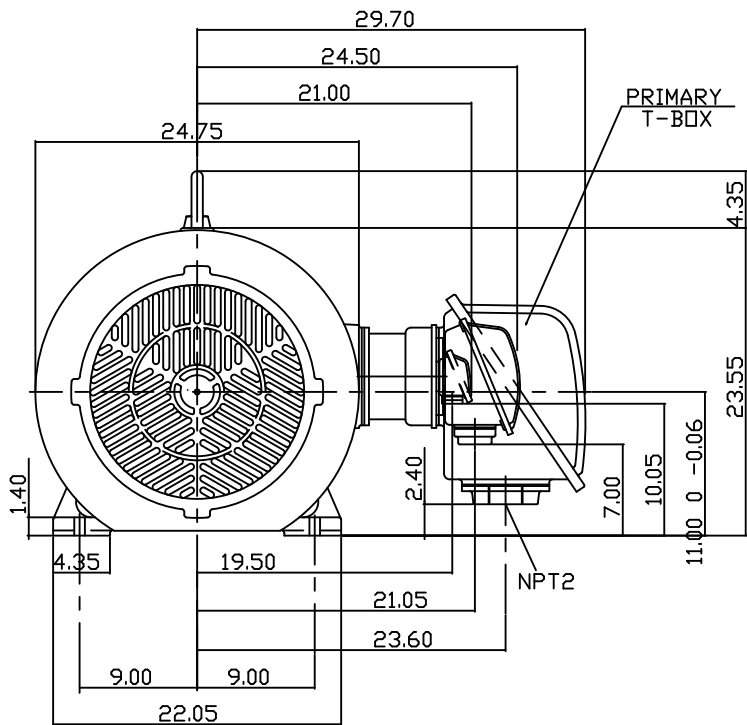

NOTE:

1. DIMENSIONS IN INCH
2. FRAME NO. 449T
3. F CLASS INSULATION, S.F.1.15
4. FOR DIRECT FLEXIBLE COUPLING
5. WITH WINDING RTD & SPACE HEATER
6. ENCLOSURE: IP54
7. BEARING SIZE DRIVE END: NU320
NON-DRIVE END: 6316
8. APPROX. WEIGHT: 2730 LBS

TW-56C

DATE: MAY 13, 2013	OUTLINE DIMENSIONS
CATALOG # KG1506R	3-PHASE INDUCTION MOTOR

DWN.	C. COOK	09-20-13

TEC Westinghouse

DWG NO. REV: 00
3B040C101