

TYPE	OUTPUT HP.	OUTPUT KW.	POLE	TIME RATING	VOLTAGE V	Hz	SYNSPEED R.P.M.
AEH8N	150	111.9	4	CONT.	460	60	1800

TOTALLY ENCLOSED FAN-COOLED TYPE, SQUIRREL-CAGE ROTOR

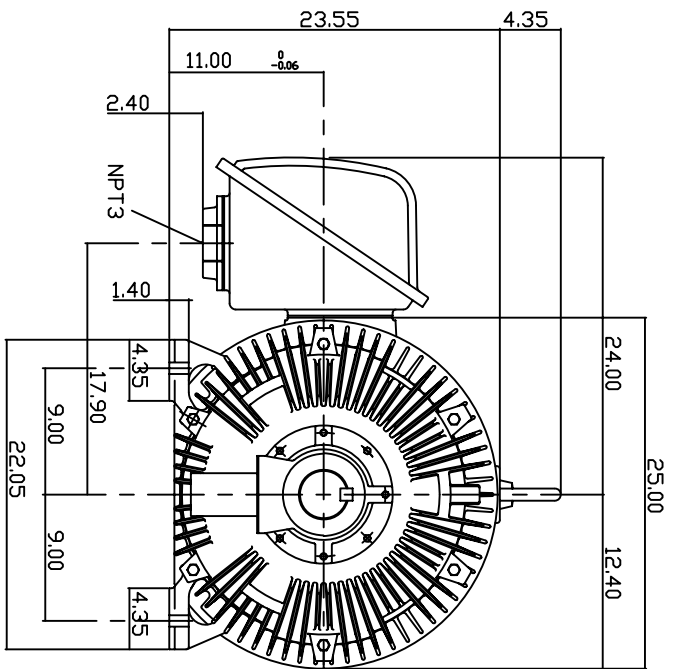
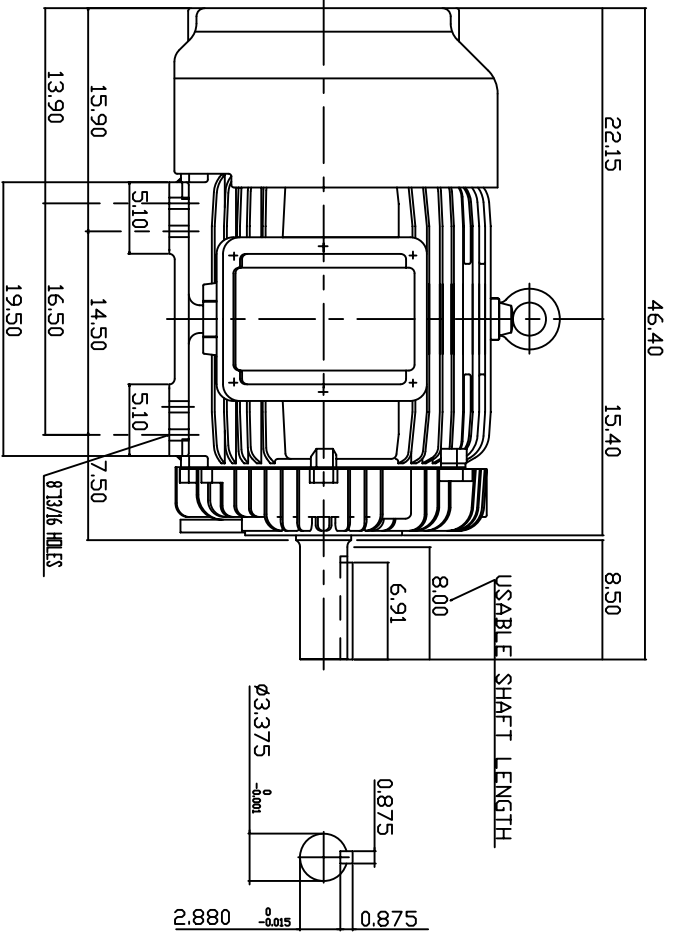

NOTE:

1. DIMENSIONS IN INCH
2. FRAME NO. 445T
3. F CLASS INSULATION, S.F.115
4. FOR BELTED SERVICE
5. ENCLOSURE: IP54
6. BEARING SIZE: DRIVE END: NU318
NON-DRIVE END: 6316
7. APPROX. WEIGHT: 1900 LBS

TW-56C

DWN.	S.DING	JAN '28 '2005
CHKD.	H.HUANG	JAN '28 '2005
APPD.	C.WANG	JAN '28 '2005

DATE 20050616
CATALOG # EP1504R

OUTLINE DIMENSIONS
3-PHASE INDUCTION MOTOR



DWG NO. 3A040Y651
REV: 00