

DATE
APRIL 5, 2011
CAT. #: XP1002C

OUTLINE DIMENSIONS
3-PHASE INDUCTION MOTOR

MOTOR TYPE:
AEHHXF
FRAME NO. 405TSC

| Pole | HP | KW | Hz | VOLT | Syn. Speed r/min(rpm) |
|------|-----|----|----|---------|--------------------------|
| 2 | 100 | 75 | 60 | 230/460 | 3600 |

| Ins | Rating | Dimension in | Approx Weight | Bearings |
|-----|--------|--------------|---------------|------------------------|
| F | CONT. | inches | 1360 LBS | DE: 6313C3 NDE: 6313C3 |

Totally Enclosed Fan Cooled Type. Squirrel-cage Rotor.

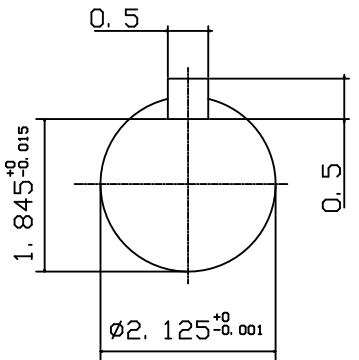
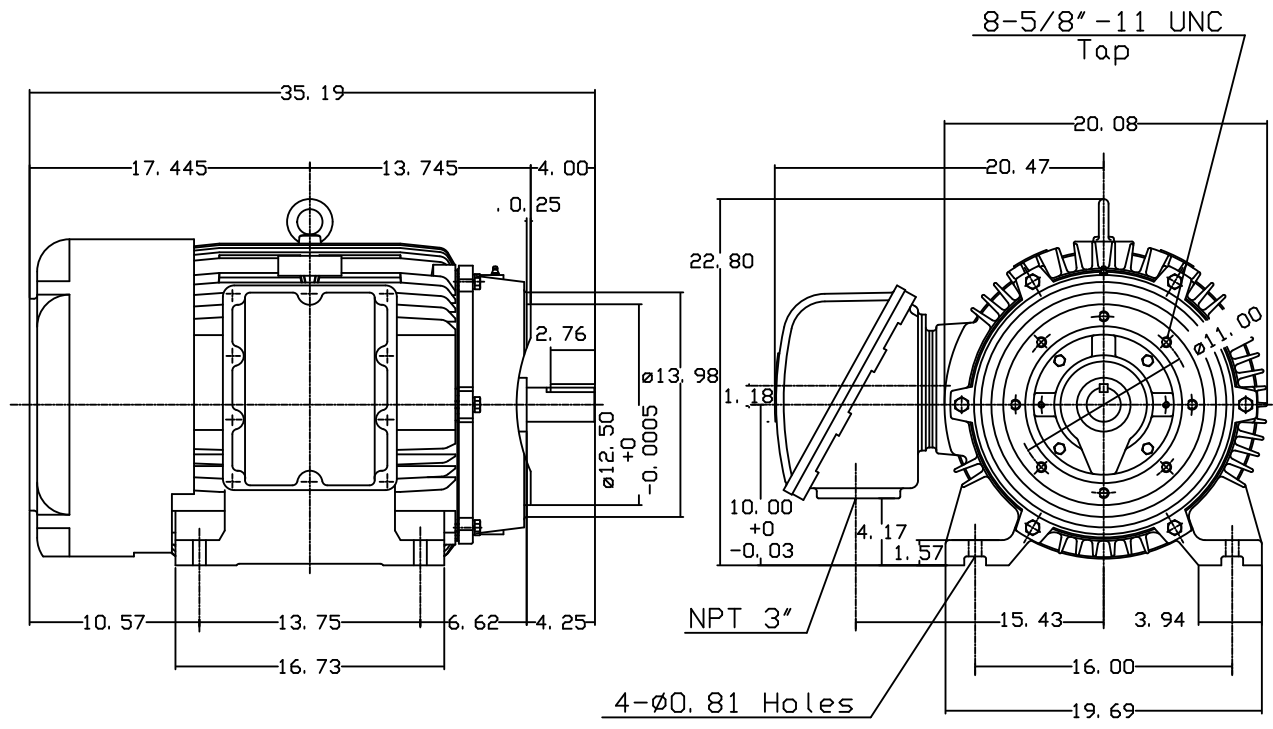

Note:
1. Explosion proof:
Class I Group D and
Class II Group E, F, G.

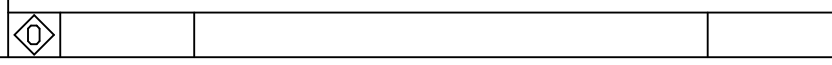

| | | |
|-------|-------------|----------|
| DWN. | J. H. LIANG | 11-30-00 |
| CHKD. | C. H. KAO | 03-07-01 |
| APPD. | Y. B. HUANG | 03-07-01 |



DWG NO.
31049M634220