

### Dimensional Drawing

| Catalogue | Model  | HP | Pole | kW  | Rating     | Voltage | Hz | RPM  |
|-----------|--------|----|------|-----|------------|---------|----|------|
| PDH01045C | AEHH8N | 10 | 4    | 7.5 | Continuous | 575 V   | 60 | 1800 |

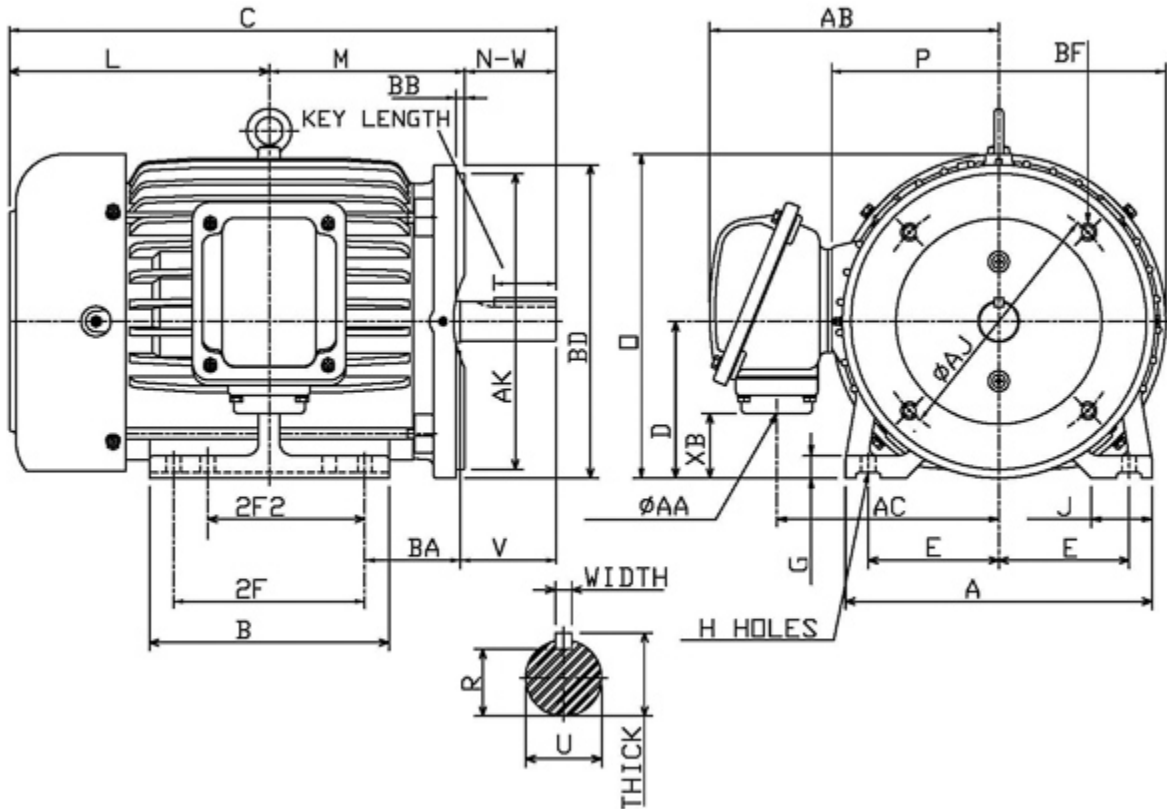

| Frame Size       | Mounting |      |          |        |                    | A           | B          | C     | CD                           | D          |           |
|------------------|----------|------|----------|--------|--------------------|-------------|------------|-------|------------------------------|------------|-----------|
|                  | E        | 2F   | 2F2      | H      | BA                 |             |            |       |                              |            |           |
| 215TC            | 4.25     | 7    | 5.5      | 0.41   | 3.5                | 9.85        | 8.35       | 19.48 |                              | 5.25       |           |
| G                | J        | K    | L        | M      | O                  | P           | T          | Key   |                              |            | Keyseat   |
| 0.7              | 1.75     |      | 9.1      | 6.81   | 10.8               | 11.1        | 1.46       | Width | Thick                        | Length     | R         |
|                  |          |      |          |        |                    |             |            | 0.312 | 0.312                        | 2.41       | 1.201     |
| Terminal Housing |          |      | Aux Box  |        |                    | C/D Flange  |            |       |                              |            |           |
| AA               | AB       | AC   | XB       | AE     | AX                 | BB          | AH         | AK    | BD                           | AJ         | BF        |
| 1 NPT            | 9.78     | 7.34 | 2.34     |        |                    | 0.25        | 3.12       | 8.5   | 9                            | 7.25       | 1/2-13UNC |
| Shaft Extension  |          |      | Bearings |        | Approx. Weight Lbs | SPL dBA/3ft | Ins. Class | S.F.  | Drive Method                 | Dimensions |           |
| N-W              | U        | V    | DE       | NDE    |                    |             |            |       |                              |            |           |
| 3.38             | 1.375    | 3.3  | 6308ZZ   | 6306ZZ | 200                | 60          | F          | 1.15  | Direct Coupling / Belt Drive | Inches     |           |

### Technical Data Sheet

Motor Type: AEHH8N

Catalogue No: PDH01045C

#### Nameplate Information

|           |            |                |             |             |              |                |
|-----------|------------|----------------|-------------|-------------|--------------|----------------|
| HP        | Pole       | RPM            | Frame       | Voltage     | Hz           | Phase          |
| 10        | 4          | 1755           | 215TC       | 575         | 60           | 3              |
| Enclosure | Ins. Class | Service Factor | Time Rating | NEMA Design | Rated Amb.   | Rated Altitude |
| TEFC      | F          | 1.15           | Continuous  | B           | -40 to 40 °C | <3300 ft       |

#### Typical Performance

| Efficiency (%)    |                             |                                 |                                      | Power Factor (%)    |           |                                |
|-------------------|-----------------------------|---------------------------------|--------------------------------------|---------------------|-----------|--------------------------------|
| Full Load         |                             | 3/4 Load                        | 1/2 Load                             | Full Load           | 3/4 Load  | 1/2 Load                       |
| Nom.              | Min.                        |                                 |                                      |                     |           |                                |
| 91.7              | 90.2                        | 91.0                            | 91.0                                 | 88.0                | 84.0      | 75.5                           |
| Torque            |                             |                                 |                                      | Current (A)         |           |                                |
| Full Load (lb-ft) | Locked Rotor (% FLT)        | Pull Up (% FLT)                 | Break Down (% FLT)                   | No Load             | Full Load | Locked Rotor                   |
| 29.92             | 250                         | 145                             | 260                                  | 2.7                 | 9.3       | 65                             |
| NEMA KVA Code     | Inertia (WR <sup>2</sup> )  |                                 |                                      | Safe Stall Time (s) |           | Noise Level Sound Press. dB(A) |
|                   | Rotor (lb-ft <sup>2</sup> ) | NEMA Load (lb-ft <sup>2</sup> ) | Max. Allowable (lb-ft <sup>2</sup> ) | Cold                | Hot       |                                |
| H                 | 1.082                       | 51.0                            | 175.0                                | 40                  | 28        | 60                             |

#### VFD Duty Information

| Speed Range     |                 |                | VFD     |              | S.F. |
|-----------------|-----------------|----------------|---------|--------------|------|
| Constant Torque | Variable Torque | Constant Power | Carrier | Type         |      |
| 6-60Hz          | 3-60Hz          | 60-120Hz       | ≤ 5 kHz | VPWM or CPWM |      |

#### Additional Information

| Bearings |        | Approx. Weight |
|----------|--------|----------------|
| DE       | NDE    | lbs            |
| 6308ZZ   | 6306ZZ | 200            |

#### Hazardous Locations Information

| CSA Certified                             |           |
|---|-----------|
| Class I, Div 2, Groups B, C & D           |           |
| Class I, Zone 2, Groups IIB+H2, IIB & IIA |           |
| Temp Code (Sinewave / VFD)                | T3C / T3B |