

# Product Information Packet

January 12, 2017

Data shown is for the current revision model #. Ensure your nameplate model # matches.

<b>Model Number:</b>	<b>5KS513AAG206A</b>
<b>Catalog Number:</b>	<b>P384</b>
<b>Instruction Manual:</b>	GEI-100351
<b>Connection Diagram:</b>	GEM2034E-FIG2
<b>Outline Drawing:</b>	50DP4187G004DBT

Accessory Connection Diagrams			
<b>Bearing Thermocouple:</b>	None	<b>Heater:</b>	3027JE-1C
<b>RTD:</b>	235A3027XC	<b>Thermistor:</b>	None
<b>Thermostat:</b>	None	<b>Winding Thermocouple:</b>	None
<b>Bearing RTD:</b>	None		

## Table of Contents

Specification	01
Performance Characteristics	02
Outline Drawing	03
Connection Drawing(s)	04
Spare parts	05



**Marks:**

<b>MODEL NUMBER:</b>	<b>5KS513AAG206A</b>	<b>Estimated Weight:</b>	5400 Lbs
<b>Outline Drawing:</b>	50DP4187G004DBT	<b>Time Rating:</b>	CONT
<b>Connection Diagram:</b>	GEM2034E-FIG2	<b>Enclosure:</b>	WPI
<b>Instruction Book:</b>	GEI-100351	<b>Encl Construction:</b>	OPEN
<b>Design Code:</b>	50ED1320E	<b>Ambient Max(°C):</b>	40
<b>Type:</b>	KS	<b>Alt Ambient Max(°C):</b>	XX
<b>Frame:</b>	5013S	<b>Insulation Class:</b>	F
<b>Phases:</b>	3	<b>NEMA Design:</b>	-
<b>Poles:</b>	4	<b>Nominal Efficiency:</b>	96.2 %
<b>Output Power:</b>	1000HP 740KW	<b>Guaranteed Efficiency:</b>	95.4
<b>RPM:</b>	1780	<b>3/4 Load Efficiency:</b>	96.6
<b>Voltage:</b>	2300/4000	<b>KVA Code:</b>	F
<b>Hertz:</b>	60	<b>Max KVAR:</b>	182.5
<b>Amps - FL:</b>	217.4/125.0	<b>Power Factor:</b>	89.5
<b>Service Factor:</b>	1.15	<b>Bearing - DE:</b>	SLEEVE
<b>Alt Service Factor:</b>	XX	<b>Bearing - ODE:</b>	SLEEVE

**Enclosure is Weather Protected One**

**Stamped Nameplate Notes:**

NEMA ENCLOSURE WP-I, CSA ENCL DP  
 GE SELF DECLARED CLASS I DIV 2 MOTOR  
 MAX EXPOSED INTERNAL AND EXTERNAL SURFACE  
 TEMPERATURES UNDER USUAL SERVICE CONDITION  
 AT 1.00 S.F. DO NOT EXCEED 200 DEG C  
 VIBRATION LIMIT = 0.150 IN/SEC  
 TEMP CONTRL HTR LDS HE1-HE2 115V 200W  
 MAXIMUM SPACE HEATER SURFACE  
 TEMPERATURE 160 DEG C

**Additional Information:**

4 POLE, S SHAFT EXTN  
 FORMED COIL  
 SLEEVE BEARINGS  
 (2)GROUND BOLTS ON FRAME  
 TEMP CONTRL 115V HEATER LEADS TO ACC BOX  
 100 OHM WINDING RTD LEADS TO ACC BOX  
 SUGGESTED WINDING RTD SETTINGS  
 ALARM 165C TRIP 175C  
 100 OHM BEARING RTD BOTH ENDS  
 SUGGESTED BEARING RTD SETTINGS  
 ALARM 90C TRIP 100C  
 2500 Cu. In. CBOX  
 DP-WPI STOCK 09/23/16  
 ENGINEER : HAREHARAN B/NATH T

**Performance Characteristics**

1st Winding 1st Connection

**Design: 50ED1320E**

**Marks:**

LOAD %	125.0	115.0	100.0	75.0	50.0	25.0	0.0
% EFF	95.42	95.71	96.3	96.6	96.79	95.89	0.00
% PF	89.36	89.56	90.37	88.17	83.15	65.23	2.92
AMPS	157.79	144.4	123.56	94.78	66.87	43.02	29.27

**TORQ(FL)#FT** 2947.06  
**AMPS(LR)** 791.14

**TORQ(LR)%FL** 108.31  
**PF AT START** 0.22

**TORQ(BD)%FL** 230.19

This motor is capable of two cold or one hot start with a maximum connected load inertia of 4038 Lb-Ft Sq (170 Kg-meter Sq)at 100% voltage, where the load torque varies with the square of the speed. Acceleration time with maximum inertia and the above load type is 9 seconds. Safe stall time at 100% voltage is 38 seconds cold, 17 seconds hot. Rotor inertia is 242.28 Lb-Ft Sq (10.2 Kg-meter Sq).

**Open Circuit A-C:** 1.096

**Short Circuit D-C:** 0.025

**Short Circuit A-C:** 0.038

**X/R Ratio:** 9.571

**Stator Slots:** 72

**Rotor Slots:** 58

**Speed Torque Current Curve (First Connection, First Speed)**

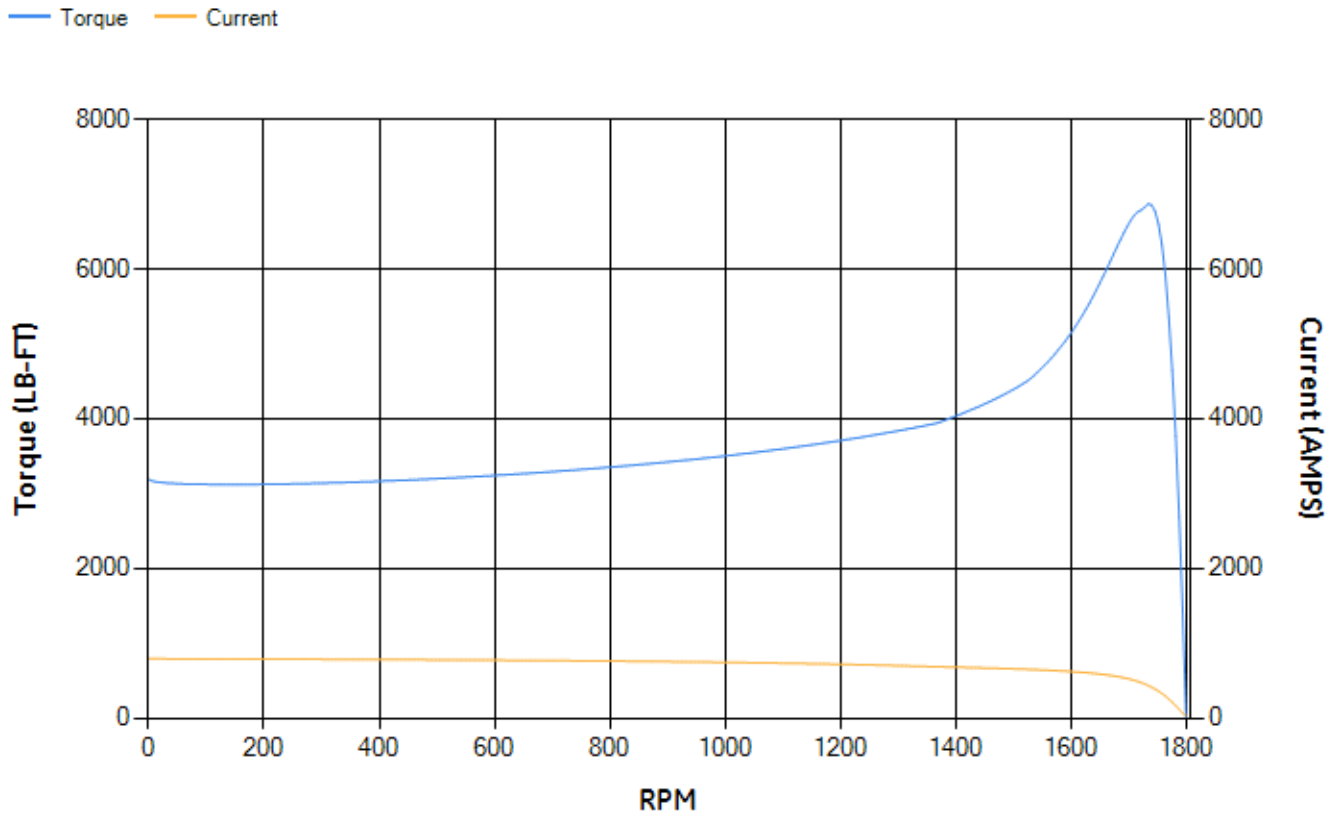

Marks:

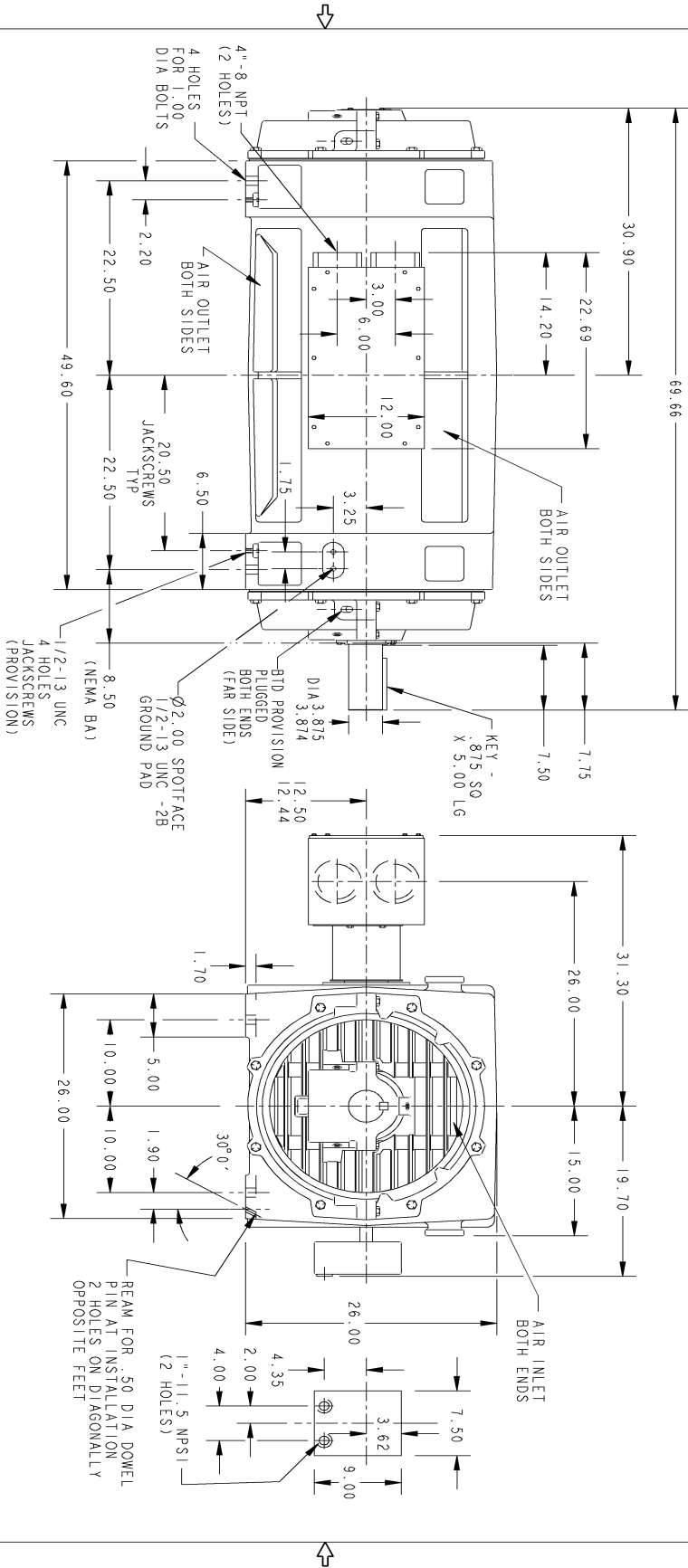

- NOTES:
- CONDUIT BOX MAY BE TURNED SO THAT ENTRANCE CAN BE MADE UPWARDS, DOWNWARDS, OR FROM EITHER SIDE. WHEN DOWNWARDS ENTRANCE IS BELOW THE FEET.
  - F-1 ASSEMBLY SHOWN. F-2 ASSEMBLY HAS CONDUIT BOX LOCATED OPPOSITE SIDE.

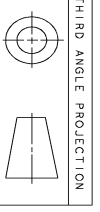

SIZE DRAWING NO. **B** REV SHEET **0** **50DP4187G004DBT**

REV.	DESCRIPTION	DATE	APPROVED

SIGNATURES	DATE	<p><b>GENERAL ELECTRIC COMPANY</b></p> <p><b>OUTLINE</b></p> <p><b>5013 S DP SLEEVE BRG JACK SCREW PROV.</b></p> <p><b>2500 CU INL BOX &amp; ACC C/B, DUAL GROUND PAD, RTD PROV.</b></p> <p><b>50DP4187G004DBT</b></p>
MODEL	RAJU K 09/29/16	
DETAIL	TRIPATI 09/29/16	
CHECKED	TRIPATI 09/29/16	
ENGR	TRIPATI 09/29/16	
ISSUED	RAJU K 09/29/16	
QUALITY		
SCALE: .09		REV <b>0</b>
SHEET 1 of 1		

Marks:

**Connection Diagram**  
**GEM2034E-FIG2**

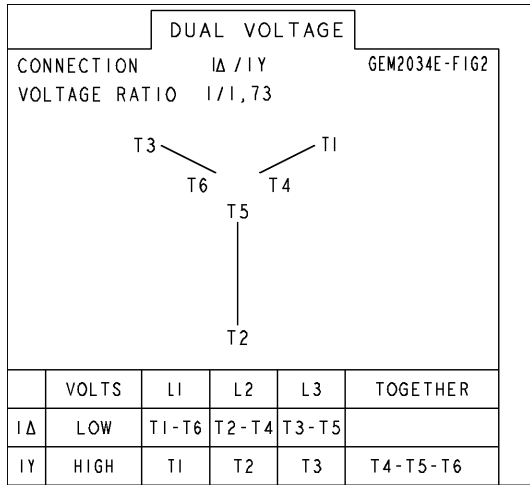

**Heater Connection**  
**3027JE-1C**



SHEET 0  
REV 0  
235A3027XC  
A  
SIZE DRAWING NO.

**GE PROPRIETARY INFORMATION**  
This document is the property of General Electric Company ("GE") and contains proprietary information of GE. This document is loaned on the express condition that neither it nor the information contained therein shall be disclosed to others without the express written consent of GE Industrial Systems, and that the information shall be used by the recipient only as approved expressly by GE Industrial Systems. This document shall be returned to GE upon its request. This document may be subject to certain restrictions under U.S. export control laws and regulations.

REVISIONS			
REV.	DESCRIPTION	DATE	APPROVED

THIRD ANGLE PROJECTION

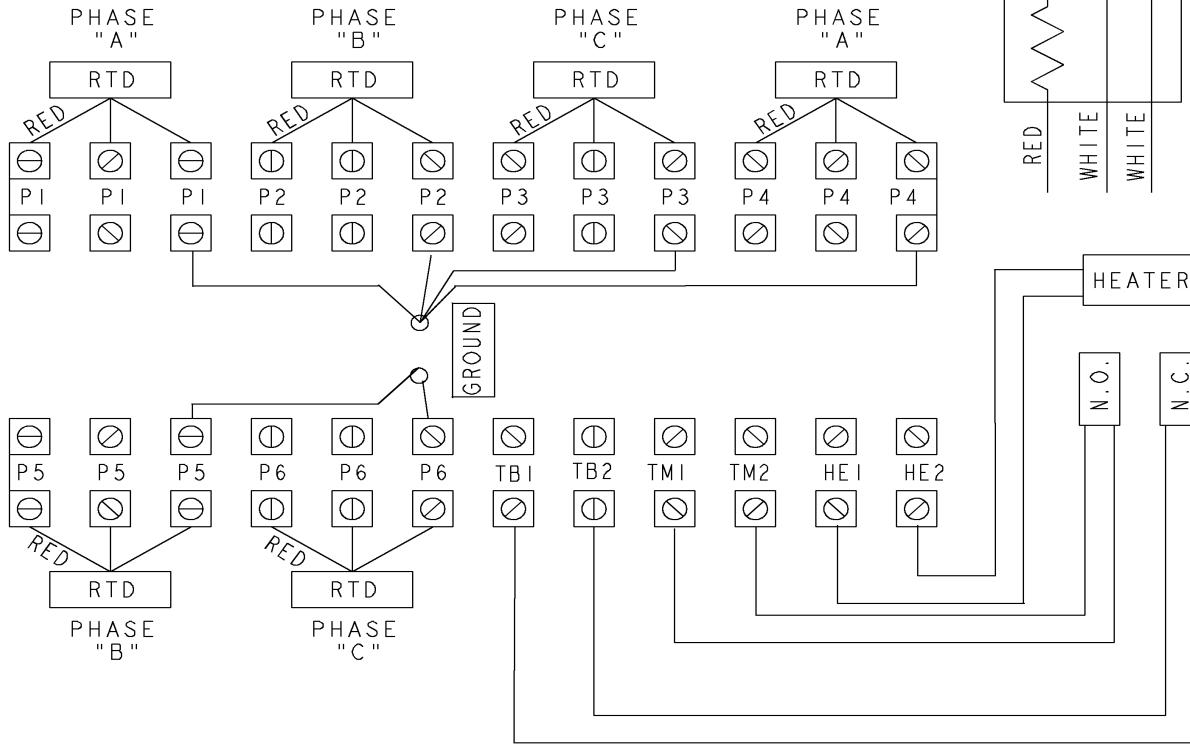
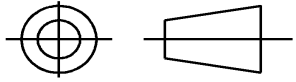

- NOTE 1: TERMINAL LABELS ARE PROVIDED FOR ACCESSORIES THAT MAY OR MAY NOT BE INCLUDED WITH THE MOTOR.
- NOTE 2: SPARE RTDS (P7 & P8) FURNISHED IN CASE OF FAILURE IN OTHER RTDS (P1-P6). PHASE LOCATION WILL DEPEND UPON NUMBER OF POLES WINDING CONFIGURATION.
- NOTE 3: IT IS RECOMMENDED THAT RTDS BE GROUNDED AT EITHER THE MACHINE OR CONNECTED TO A GROUNDED CONTROL CIRCUIT. FOR PROPER OPERATION DO NOT GROUND AT THE MACHINE IF CONNECTED TO A GROUND CIRCUIT AT THE CONTROL.

Part must conform to SI 900000 Sect. 4, Toxicity Procedure

FOR ADDITIONAL INFO REFER TO:	SIGNATURES	DATE
APPLIED PRACTICES	MODEL	
DIMENSIONS ARE IN INCHES	DETAIL VIVEK	01/08/15
TOLERANCE ON:	CHECKED KARTHIK	01/08/15
1 PL DECIMALS ± 0.1	ENGRG	
2 PL DECIMALS ± 0.02	MFG	
3 PL DECIMALS ± 0.005	QUALITY	
ANGLES ± 0.5	ISSUED VIVEK	01/08/15
FRACTIONS ±		
FINISH ✓		
MATERIAL	SOLID MODEL: MODEL NAME	

**GE Motors** GENERAL ELECTRIC COMPANY

TITLE: **CONNECTION DIAGRAM**  
IEC  
WINDING RTD'S & T'STATS & HEATERS

SIZE DRAWING: A  
235A3027XC  
REV 0

SCALE: NA  
SHEET 1 of 1

End shield Assembly		
Part Description	DE Side Part#	ODE Side Part#
End Shield	119D1877DH2	119D1877DP1
Bearing	153B4435AD-G01	153B4435AD-G01
Slinger/Inproseal		

Fan & Fan Cover Assembly	
Part Description	Part#
Fan	
Fan Cover	

Conduit & Accessories Box Assembly	
Part Description	Part#
Conduit Box	179B9025G01

Mechanical Accessories	
Part Description	Part#
Brake	
Tachometer	

