

Product Information Packet

June 16, 2017

Data shown is for the current revision model #. Ensure your nameplate model # matches.

Model Number:	5KS405DAJ6022B
Catalog Number:	V4425
Instruction Manual:	GEK-95353
Connection Diagram:	GEM2034E-FIG19
Outline Drawing:	148CB40VMHKCCAA0001

Accessory Connection Diagrams			
Bearing Thermocouple:	None	Heater:	3027JE-1C
RTD:	None	Thermistor:	None
Thermostat:	None	Winding Thermocouple:	None
Bearing RTD:	None		

Table of Contents

Specification	01
Performance Characteristics	02
Outline Drawing	03
Connection Drawing(s)	04
Spare parts	05



Marks:

MODEL NUMBER:	5KS405DAJ6022B	Estimated Weight:	1200 Lbs
Outline Drawing:	148CB40VMHKCCAA0001	Time Rating:	CONT
Connection Diagram:	GEM2034E-FIG19	Enclosure:	WPI
Instruction Book:	GEK-95353	Encl Construction:	OPEN
Design Code:	40BD1119AB	Ambient Max(°C):	40
Type:	KS	Alt Ambient Max(°C):	--
Frame:	L405TP16	Insulation Class:	H
Phases:	3	NEMA Design:	B
Poles:	4	Nominal Efficiency:	95.4 %
Output Power:	125HP 92.5KW	Guaranteed Efficiency:	94.5 %
RPM:	1785	3/4 Load Efficiency:	94.9 %
Voltage:	460	KVA Code:	G
Hertz:	60	Max KVAR:	40.4
Amps - FL:	149.0	Power Factor:	82.5
Service Factor:	1.15	Bearing - DE:	6215C3
Alt Service Factor:	--	Bearing - ODE:	235A2532AA01

Enclosure is Weather Protected One

Stamped Nameplate Notes:

HTR LDS HE1-HE2 115V 100W
 ROT CCW FACING ODE LEAD/PH SEQ 1-2-3/1-2-3
 INVERTER DUTY PER NEMA MG1 PART 31
 ALTERNATE RATING FOR PWM CONTROL:1.0SF 40C AMBIENT
 VAR TORQUE RANGE 5-60 HZ
 UPPER BRG LUBE OIL: 6 QTS
 0 DEG C TO 40 DEG C : ISO 32(MINERAL OR SYNTHETIC)
 -15 DEG C TO 0 DEG C : ISO 32 SYNTHETIC
 SUITABLE FOR 100 HP, 380V, 50 HZ WITH
 145.0 AMPS AND 1485 RPM AT 1.0 SF

Additional Information:

4P, VERT HOLLOW SHAFT HIGH THRUST (2D)
 700 CU IN - 3.00" NPT
 OIL RESISTANT SLEEVING ON LEADS
 115V HTR LDS TO MAIN CONDUIT BOX
 BEARING LIFE 8760 HRS AT 14609 LB THRUST
 PART WINDING START
 CG:18.50 IN FROM P-BASE FACE, STAT DEF:0.0033 IN
 RCF:3240 CPM AT C/BOX SIDE, 3360 CPM AT
 90 DEG FROM C/ BOX SIDE
 NON-REVERSE BALL CARRIER
 COUPLING NOT INCLUDED IN BOM, WILL BE
 ORDERED SEPERATELY
 SPECIAL BALANCE

Performance Characteristics

1st Winding 1st Connection

Design: 40BD1119AB

Marks:

LOAD %	125.0	115.0	100.0	75.0	50.0	25.0	0.0
% EFF	94.63	94.79	95.15	94.91	94.11	90.64	0.00
% PF	83.38	83.15	82.27	78.63	69.68	48.18	4.81
AMPS	185.33	170.69	149.46	117.57	89.2	66.97	56.3

TORQ(FL)#FT	367.66	TORQ(LR)%FL	139.74	TORQ(BD)%FL	220.1
AMPS(LR)	729.84	PF AT START	0.29		

This motor is capable of two cold or one hot start with a maximum connected load inertia of 3197 Lb-Ft Sq (134.59 Kg-meter Sq)at 100% voltage, where the load torque varies with the square of the speed. Acceleration time with maximum inertia and the above load type is 52 seconds. Safe stall time at 100% voltage is 95 seconds cold, 62 seconds hot. Rotor inertia is 25.78 Lb-Ft Sq (1.09 Kg-meter Sq).

Open Circuit A-C:	0.815	Short Circuit D-C:	0.036
Short Circuit A-C:	0.053	X/R Ratio:	13.683
Stator Slots:	72	Rotor Slots:	58

Speed Torque Current Curve (First Connection, First Speed)

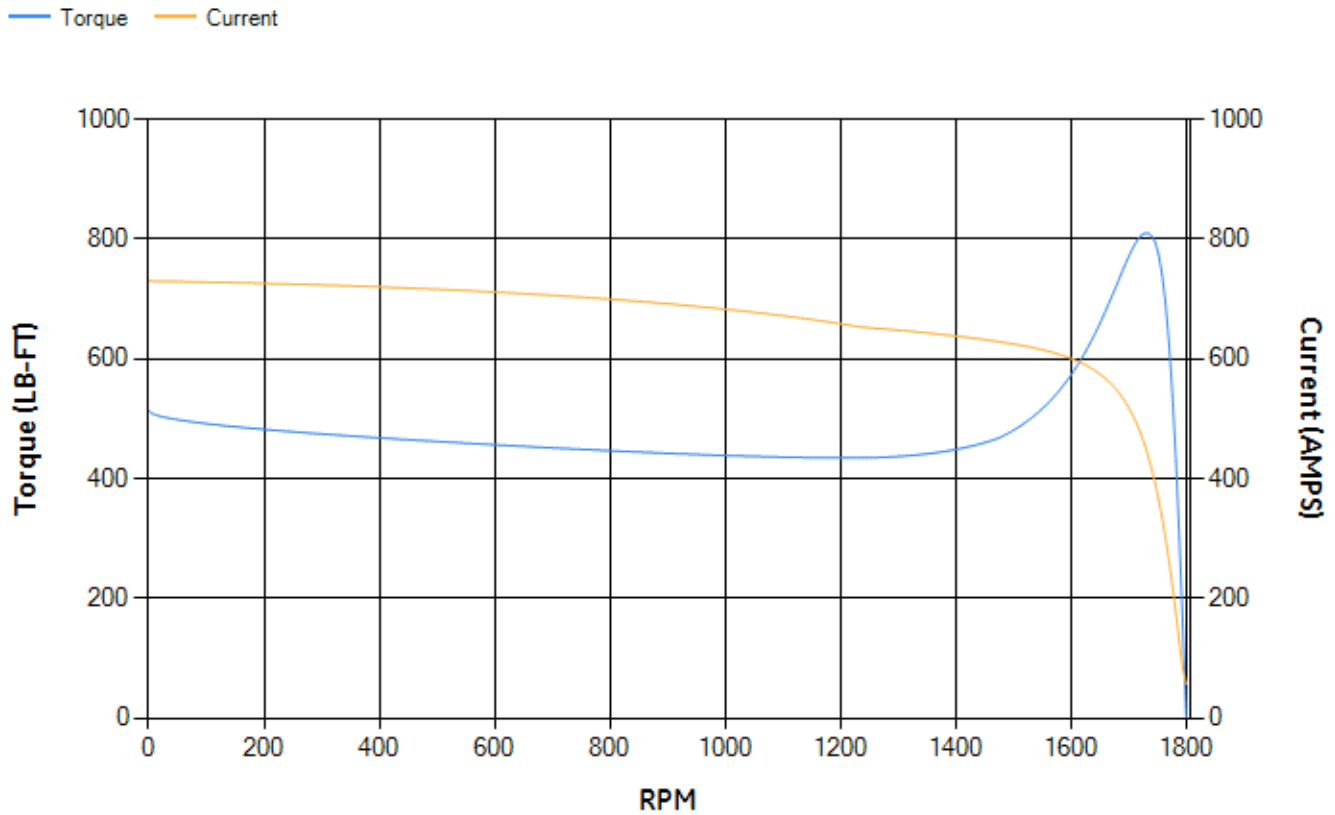

Marks:

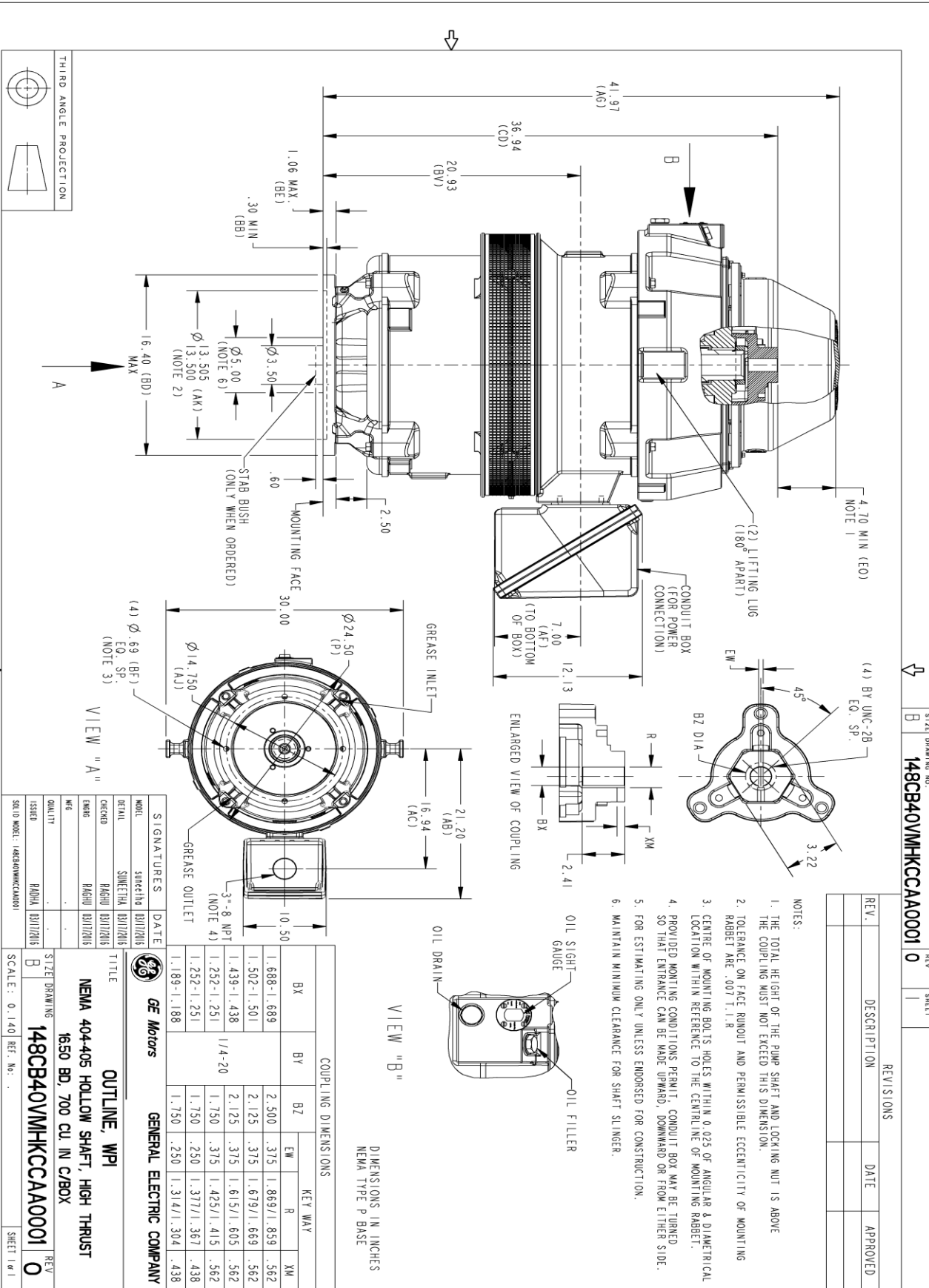

REVISIONS

REV.	DESCRIPTION	DATE	APPROVED

- NOTES:
1. THE TOTAL HEIGHT OF THE PUMP SHAFT AND LOCKING NUT IS ABOVE THE COUPLER MUST NOT EXCEED THIS DIMENSION.
 2. TOLERANCE ON FACE RUNOUT AND PERMISSIBLE ECCENTRICITY OF MOUNTING RABBET ARE .007 T.I.R
 3. CENTRE OF MOUNTING BOLTS HOLES WITHIN 0.025 OF ANGULAR & DIAMETRICAL LOCATION WITHIN REFERENCE TO THE CENTRELINE OF MOUNTING RABBET.
 4. PROVIDED MOUNTING CONDITIONS PERMIT, CONDUIT BOX MAY BE TURNED SO THAT ENTRANCE CAN BE MADE UPWARD, DOWNWARD OR FROM EITHER SIDE.
 5. FOR ESTIMATING ONLY UNLESS ENDORSED FOR CONSTRUCTION.
 6. MAINTAIN MINIMUM CLEARANCE FOR SHAFT SLINGER.

VIEW "B"

DIMENSIONS IN INCHES
NEMA TYPE P BASE

COUPLING DIMENSIONS		KEY WAY	
BX	BY	BZ	EW
1.688-1.689	2.500	.375	1.869/1.859
1.502-1.501	2.125	.375	1.679/1.669
1.439-1.438	1/4-20	2.125	.375
1.252-1.251	1.750	.375	1.425/1.415
1.252-1.251	1.750	.250	1.377/1.367
1.189-1.188	1.750	.250	1.314/1.304

VIEW "A"

GENERAL ELECTRIC COMPANY

SIGNATURES	DATE

GE Motors

DETAIL: SURETHERM QUALIZATION
ORDERED: RABBIT QUALIZATION
ENG: RABBIT QUALIZATION
MFG: RABBIT QUALIZATION
ISSUED: RABBIT QUALIZATION
SOLD MODEL: 148CB40VMHKCCAA0001

VIEW "A"

OUTLINE, WPI

NEMA 404-405 HOLLOW SHAFT, HIGH THRUST

1650 BD, 700 CU. IN. C/BOX

148CB40VMHKCCAA0001

SCALE: 0.140 REF. No.

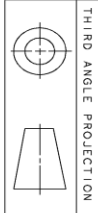

SIZE DRAWING NO. B 148CB40VMHKCCAA0001 0

REV. SHEET 1

SHEET 1 OF 1

Marks:

Connection Diagram
GEM2034E-FIG19

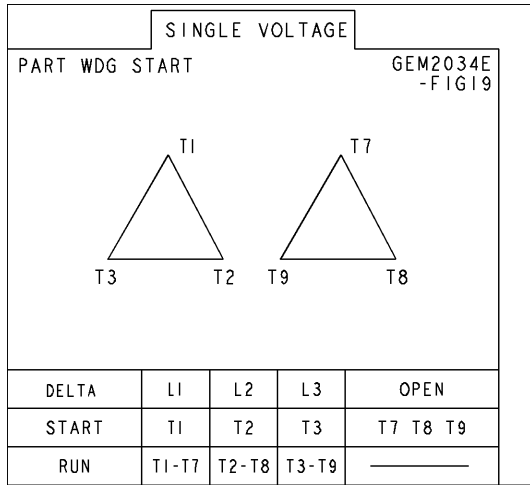

Heater Connection
3027JE-1C

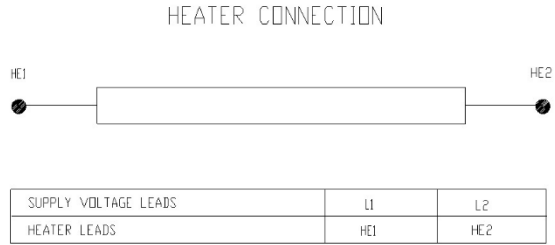

End shield Assembly		
Part Description	DE Side Part#	ODE Side Part#
End Shield	115E7306AC1	115E7310LA1
Bearing	235A2513AL01	235A2532AA01
Slinger/Inproseal	235A2300HW1	

Fan & Fan Cover Assembly	
Part Description	Part#
Fan	
Fan Cover	161C1054AA1

Conduit & Accessories Box Assembly	
Part Description	Part#
Conduit Box	118D4408AD2

Mechanical Accessories	
Part Description	Part#
Brake	
Tachometer	