

Product Information Packet

November 8, 2016

Data shown is for the current revision model #. Ensure your nameplate model # matches.

Model Number:	5KS215XAA341B
Catalog Number:	M9500
Instruction Manual:	GEI-56128
Connection Diagram:	GEM2034E-FIG1
Outline Drawing:	4002B5821PDP5310

Accessory Connection Diagrams			
Bearing Thermocouple:	None	Heater:	None
RTD:	None	Thermistor:	None
Thermostat:	None	Winding Thermocouple:	None
Bearing RTD:	None		

Table of Contents

Specification	01
Performance Characteristics	02
Outline Drawing	03
Connection Drawing(s)	04
Spare parts	05



Marks:

MODEL NUMBER:	5KS215XAA341B	Estimated Weight:	220 Lbs
Outline Drawing:	4002B5821PDP5310	Time Rating:	CONT
Connection Diagram:	GEM2034E-FIG1	Enclosure:	TEFC
Instruction Book:	GEI-56128	Encl Construction:	841
Design Code:	21BD3000A	Ambient Max(°C):	40
Type:	KS	Alt Ambient Max(°C):	--
Frame:	215TC	Insulation Class:	H
Phases:	3	NEMA Design:	B
Poles:	6	Nominal Efficiency:	89.5 %
Output Power:	5HP 3.7KW	Guaranteed Efficiency:	88.5
RPM:	1170	3/4 Load Efficiency:	90.5
Voltage:	460	KVA Code:	J
Hertz:	60	Max KVAR:	2.2
Amps - FL:	6.8	Power Factor:	77.0
Service Factor:	1.15	Bearing - DE:	6309ZC3
Alt Service Factor:	--	Bearing - ODE:	6208ZC3

Enclosure is Totally Enclosed Fan-Cooled

Stamped Nameplate Notes:

IEEE-STD-841-2009
 DE BRG 45BC03JP30 ODE BRG 40BC02JP30
 STAMP NP249A5564P051 AS BELOW:
 MODEL:5KS215XAA341B S/N: XXX
 CSA CERTIFIED CSA09.2216219 FOR EX NA IIC 200C GC
 CL 1 ZONE2 AEX NA IIC 200C;CL 1 DIV2 GRP ABCD 200C
 IN -25C <= AMB <= 40C, 1.0 SF ON SINE-WAVE PWR
 SURF TEMP 200C AT 1.15SF ON SINE-WAVE PWR
 OR 200 C VT OR 200 C CT OR 200 C CHP PWM CONTROL
 ALTERNATE RATING FOR PWM CONTROL 1.0SF 40C AMB
 VT 0-60 HZ, CT 3-60 HZ, CHP 60-90 HZ.

Additional Information:

6P - T EXTN
 C/BOX 55 CU IN-1.00 NPT
 "C" FACE AT DE ENDSHIELD ROUND FRAME
 VERTICAL MOUNT SHAFT DOWN WITH DRIPCOVER
 PAINTED FRAME ID & SHAFT,
 FAN COVER INSIDE & ODE E/S OUTSIDE
 ROUTINE AND 5 POINT VIBRATION TESTS INCL IN C/BOX
 INPRO SEAL BOTH ENDS
 E/SHLD GROUND STUD MTD ON DE C/BOX SIDE NEAR FOOT
 ROTATE D.E. E/SHIELD 90 DEG. PER OUTLINE
 SHAFT RUNOUT LIMIT .001" TIR
 COPPER WASHER UNDER HEADS OF BEARING CAP BOLTS
 APPLY TITE-SEAL (A50CD427A) ON BEARING CAP SCREWS, RABBETS,
 AND PLUG THREADS

OIL RESISTANT SLEEVING ON LEADS

Performance Characteristics

1st Winding 1st Connection

Design: 21BD3000A

Marks:

LOAD %	125.0	115.0	100.0	75.0	50.0	25.0	0.0
% EFF	87.99	88.71	89.8	90.51	90.26	86.29	0.00
% PF	79.23	78.62	77.01	71.68	60.71	39.48	5.09
AMPS	8.39	7.72	6.77	5.41	4.27	3.43	3.03

TORQ(FL)#FT	22.42	TORQ(LR)%FL	187.13	TORQ(BD)%FL	283.56
AMPS(LR)	42.82	PF AT START	0.45		

This motor is capable of two cold or one hot start with a maximum connected load inertia of 559 Lb-Ft Sq (23.53 Kg-meter Sq)at 100% voltage, where the load torque varies with the square of the speed. Acceleration time with maximum inertia and the above load type is 54 seconds. Safe stall time at 100% voltage is 121 seconds cold, 86 seconds hot. Rotor inertia is 0.91 Lb-Ft Sq (0.04 Kg-meter Sq).

Open Circuit A-C:	0.238	Short Circuit D-C:	0.01
Short Circuit A-C:	0.014	X/R Ratio:	3.642
Stator Slots:	36	Rotor Slots:	44

Speed Torque Current Curve (First Connection, First Speed)

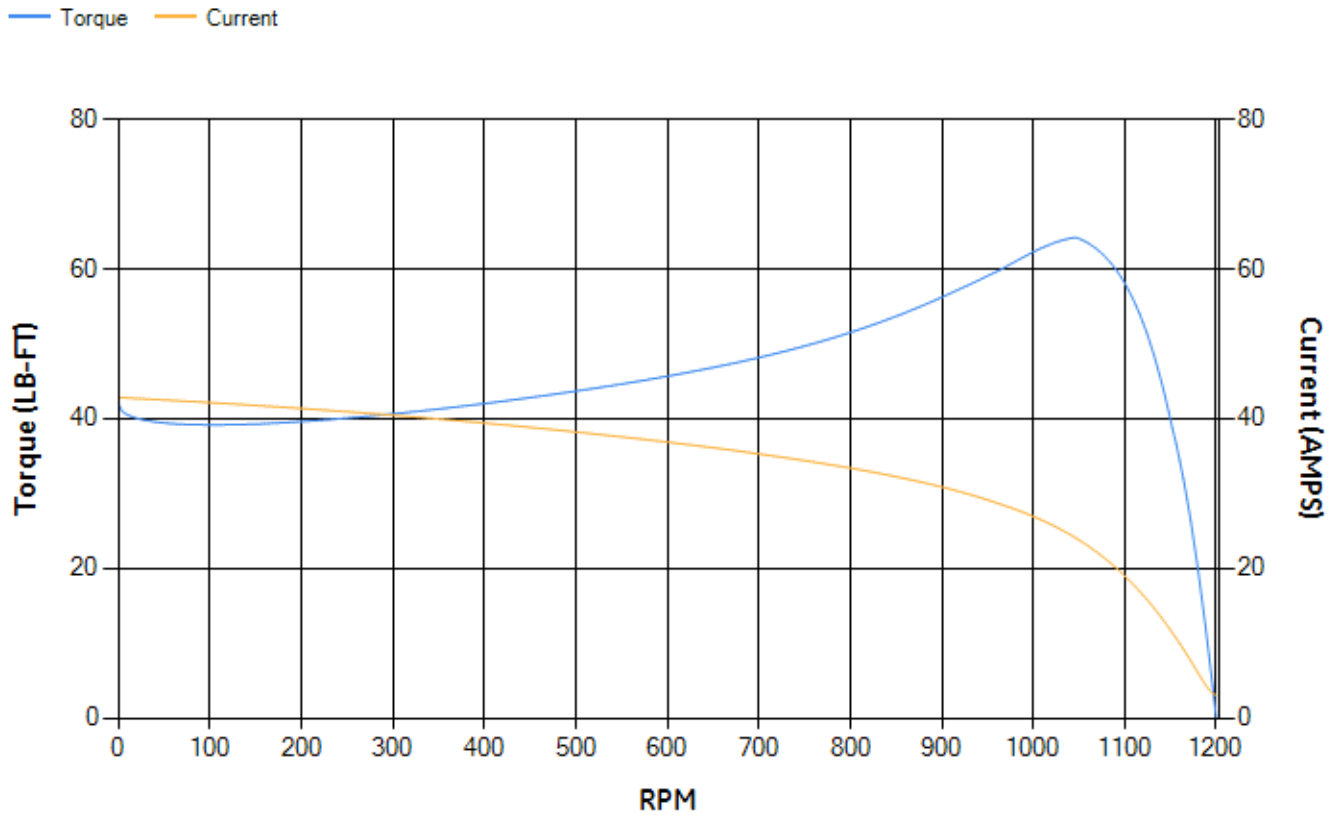

Marks:

- NOTE 1: CONDUIT BOX MAY BE ASSEMBLED WITH ENTRANCE UP, DOWN OR TO EITHER SIDE.
- NOTE 2: F1 ASSEMBLY AS SHOWN. F2 ASSEMBLY CONDUIT BOX ON OPPOSITE SIDE FROM SHOWN LOCATION.
- NOTE 3: MOUNTING SURFACES WILL BE SQUARE AND CONCENTRIC WITH SHAFT WITHIN .004 T.I.R.
- NOTE 4: SHAFT RUNOUT NOT TO EXCEED .001 T.I.R.
- NOTE 5: D.E. ENDSHIELD ROTATED 90°

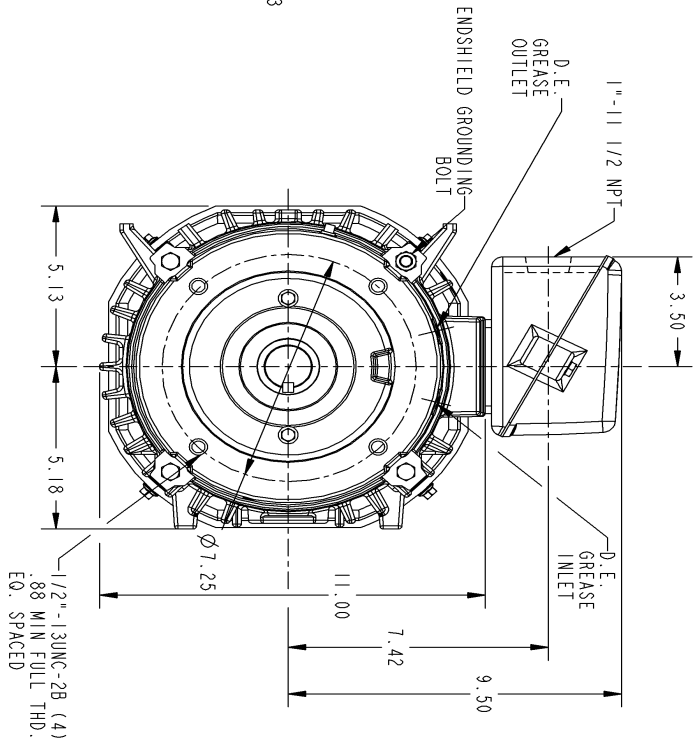
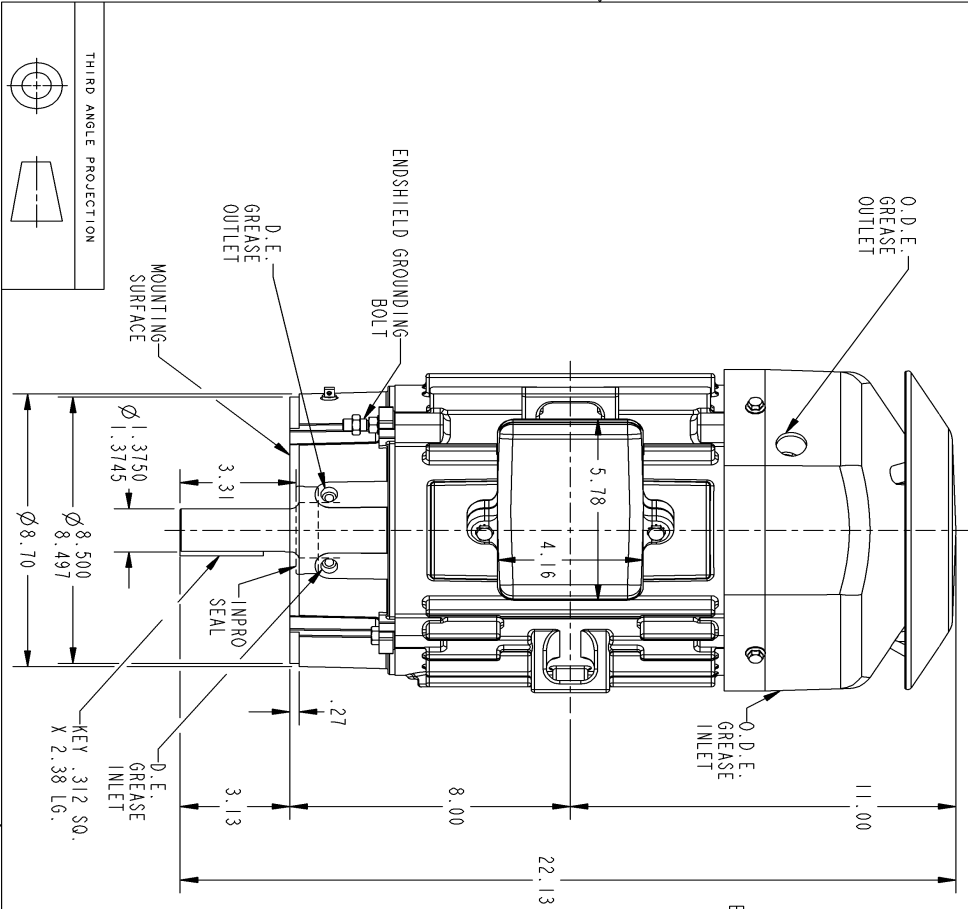

SIZE DRAWING NO.
B 4002B5821PDP5310

SM REV
1 1

REV.	DESCRIPTION	DATE	APPROVED
1	FRAME SIZE DESCRIPTION CHANGED TO 210C - N FRAM	06/06/05	TAMMY

SIGNATURES	DATE	REV
DRAM P. RAJU	10/13/03	
CHECKED SHIVA	10/13/03	
ISSUED P. RAJU	10/13/03	
APPLIED PRACTICES		

GE Industrial Systems
GENERAL ELECTRIC COMPANY
 Fort Wayne, Indiana

INDUCTION MOTOR OUTLINE
 IEEE-941 SPEC. "C" FACE AT DE FTLS WITH DRIP COVER
 FME: KS210TC TERC "C" FACE (850V RABBET)

SIZE DRAWING
4002B5821PDP5310 REV. 1

SCALE: 0.300 REF. NO.: 4002B5821PDP5310 SHEET 1 OF 1

DISTRIBUTION: PMP-18K15

Marks:

Connection Diagram
GEM2034E-FIG1



End shield Assembly		
Part Description	DE Side Part#	ODE Side Part#
End Shield	128D6006PJ1	4004D5282SJ1
Bearing	235A2607AA01	235A2603AA01
Slinger/Inproseal	235A4575GC6	4002B5914AG3

Fan & Fan Cover Assembly	
Part Description	Part#
Fan	159C6700G01
Fan Cover	4003C5521BN-G01

Conduit & Accessories Box Assembly	
Part Description	Part#
Conduit Box	4002B5721PA-G01

Mechanical Accessories	
Part Description	Part#
Brake	
Tachometer	