

DATE  
JAN 4, 2012  
CATALOG NO.  
XPO016C

# OUTLINE DIMENSIONS

## 3-PHASE INDUCTION MOTOR

MOTOR TYPE:  
AEHHXF  
FRAME NO. 145TC

Pole	HP	KW	Hz	VOLT	Syn. Speed RPM
6	1	.75	60	230/460	1200

Ins	Rating	Dimension in	Approx Weight	Bearings
F	CONT.	inches	102 lbs.	DE: 6205ZZ NDE: 6205ZZ

Totally Enclosed Fan-Cooled Type, Squirrel-Cage Rotor.

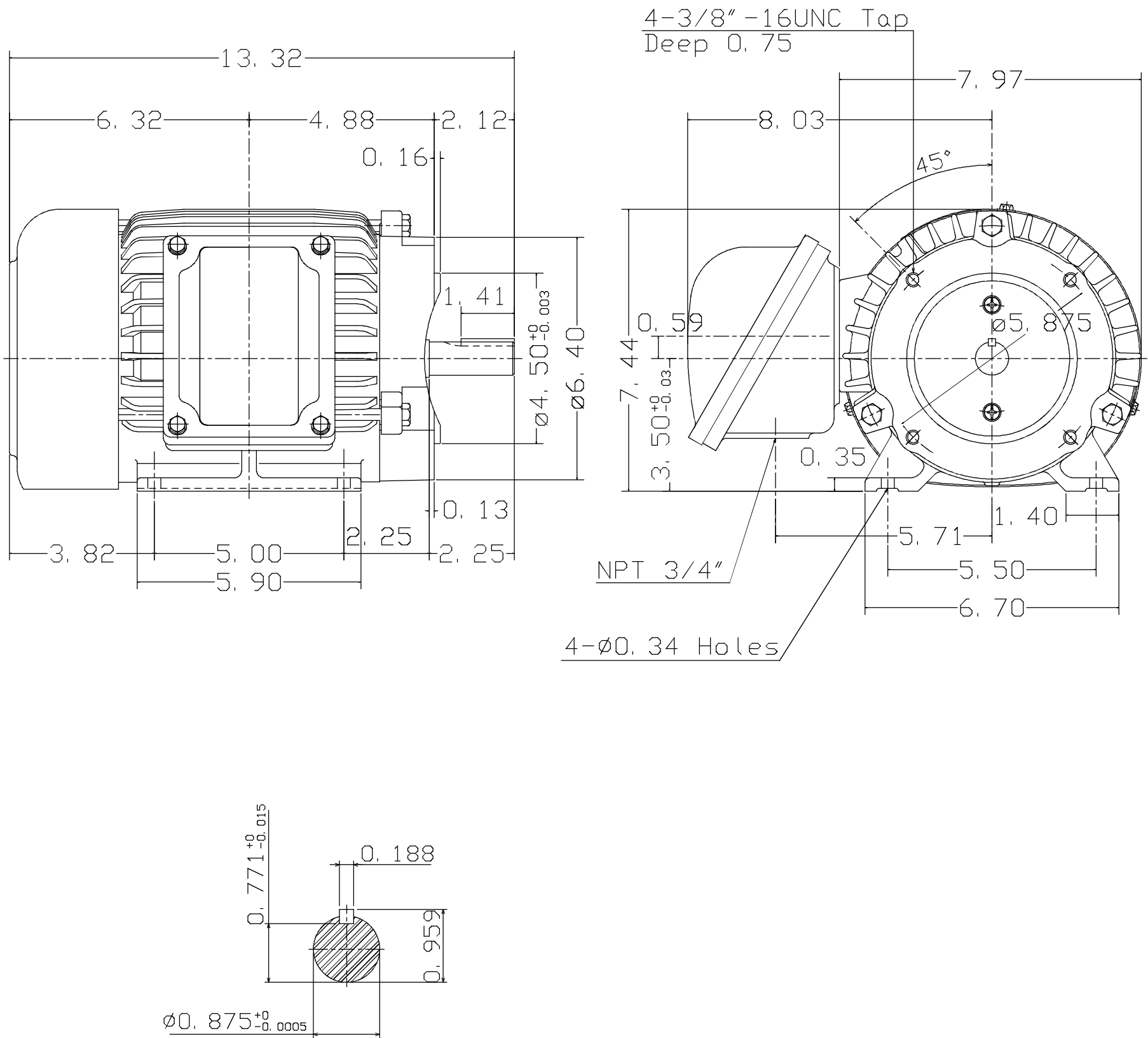

NOTE:  
1. EXPLOSION PROOF:  
CLASS I GROUP C, D AND  
CLASS II GROUP E, F, G.

--	--	--	--

DWN.	J. H. LIANG	11-12-98		DWG NO.	31049M620020
CHKD.	C. S. LO	11-23-98			
APPD.	Y. B. HUANG	11-23-98			