

Product Information Packet

November 9, 2016

Data shown is for the current revision model #. Ensure your nameplate model # matches.

Model Number:	5KS286SAA300D2
Catalog Number:	M9902
Instruction Manual:	GEI-56128
Connection Diagram:	GEM2034E-FIG7
Outline Drawing:	4002B5828PBP5316

Accessory Connection Diagrams			
Bearing Thermocouple:	None	Heater:	None
RTD:	None	Thermistor:	None
Thermostat:	None	Winding Thermocouple:	None
Bearing RTD:	None		

Table of Contents

Specification	01
Performance Characteristics	02
Outline Drawing	03
Connection Drawing(s)	04
Spare parts	05



Marks:

MODEL NUMBER:	5KS286SAA300D2	Estimated Weight:	510 Lbs
Outline Drawing:	4002B5828PBP5316	Time Rating:	CONT
Connection Diagram:	GEM2034E-FIG7	Enclosure:	TEFC
Instruction Book:	GEI-56128	Encl Construction:	X\$D
Design Code:	28BD3094A	Ambient Max(°C):	40
Type:	KS	Alt Ambient Max(°C):	65
Frame:	286TC	Insulation Class:	H
Phases:	3	NEMA Design:	B
Poles:	6	Nominal Efficiency:	91.7 %
Output Power:	20HP 14.8KW	Guaranteed Efficiency:	91.0
RPM:	1180	3/4 Load Efficiency:	92.4
Voltage:	460	KVA Code:	G
Hertz:	60	Max KVAR:	8.6
Amps - FL:	26.2	Power Factor:	78.0
Service Factor:	1.25	Bearing - DE:	6310ZC3
Alt Service Factor:	1.00	Bearing - ODE:	6310ZC3

Enclosure is Totally Enclosed Fan-Cooled

Stamped Nameplate Notes:

SF AMPS 32.1
 STAMP NP249A5564P051 AS BELOW:
 MODEL:5KS286SAA300D2 S/N: XXX
 CSA CERTIFIED CSA09.2216219 FOR EX NA IIC 200C GC
 CL 1 ZONE2 AEX NA IIC 200C;CL 1 DIV2 GRP ABCD 200C
 IN -25C <= AMB <= 40C, 1.0 SF ON SINE-WAVE PWR
 SURF TEMP 260C AT 1.25SF ON SINE-WAVE PWR
 OR 200C VT OR 215C CT OR 200C CHP PWM CONTROL
 ALTERNATE RATING FOR PWM CONTROL 1.0SF 40C AMB
 VT 0 - 60 HZ, CT 7.5-60 HZ, CHP 60-90 HZ.

Additional Information:

6P - T EXTN
 STANDARD FLOOR MOUNT
 C/BOX 137 CU IN-1.50 NPT
 F1 CONDUIT BOX MOUNTING
 "C" FACE AT DE ENDSHIELD
 INPRO SEAL DE ONLY
 OIL RESISTANT SLEEVING ON LEADS

Performance Characteristics

1st Winding 1st Connection

Design: 28BD3094A

Marks:

LOAD %	125.0	115.0	100.0	75.0	50.0	25.0	0.0
% EFF	90.77	91.26	92.06	92.43	92.06	88.54	0.00
% PF	80.3	79.62	77.92	72.45	61.19	39.34	4.17
AMPS	32.1	29.63	26.12	20.97	16.61	13.44	12.03

TORQ(FL)#FT	88.9	TORQ(LR)%FL	157.12	TORQ(BD)%FL	264.09
AMPS(LR)	142.83	PF AT START	0.36		

This motor is capable of two cold or one hot start with a maximum connected load inertia of 1029 Lb-Ft Sq (43.32 Kg-meter Sq)at 100% voltage, where the load torque varies with the square of the speed. Acceleration time with maximum inertia and the above load type is 35 seconds. Safe stall time at 100% voltage is 89 seconds cold, 52 seconds hot. Rotor inertia is 6.17 Lb-Ft Sq (0.26 Kg-meter Sq).

Open Circuit A-C:	0.346	Short Circuit D-C:	0.013
Short Circuit A-C:	0.026	X/R Ratio:	4.937
Stator Slots:	54	Rotor Slots:	42

Speed Torque Current Curve (First Connection, First Speed)

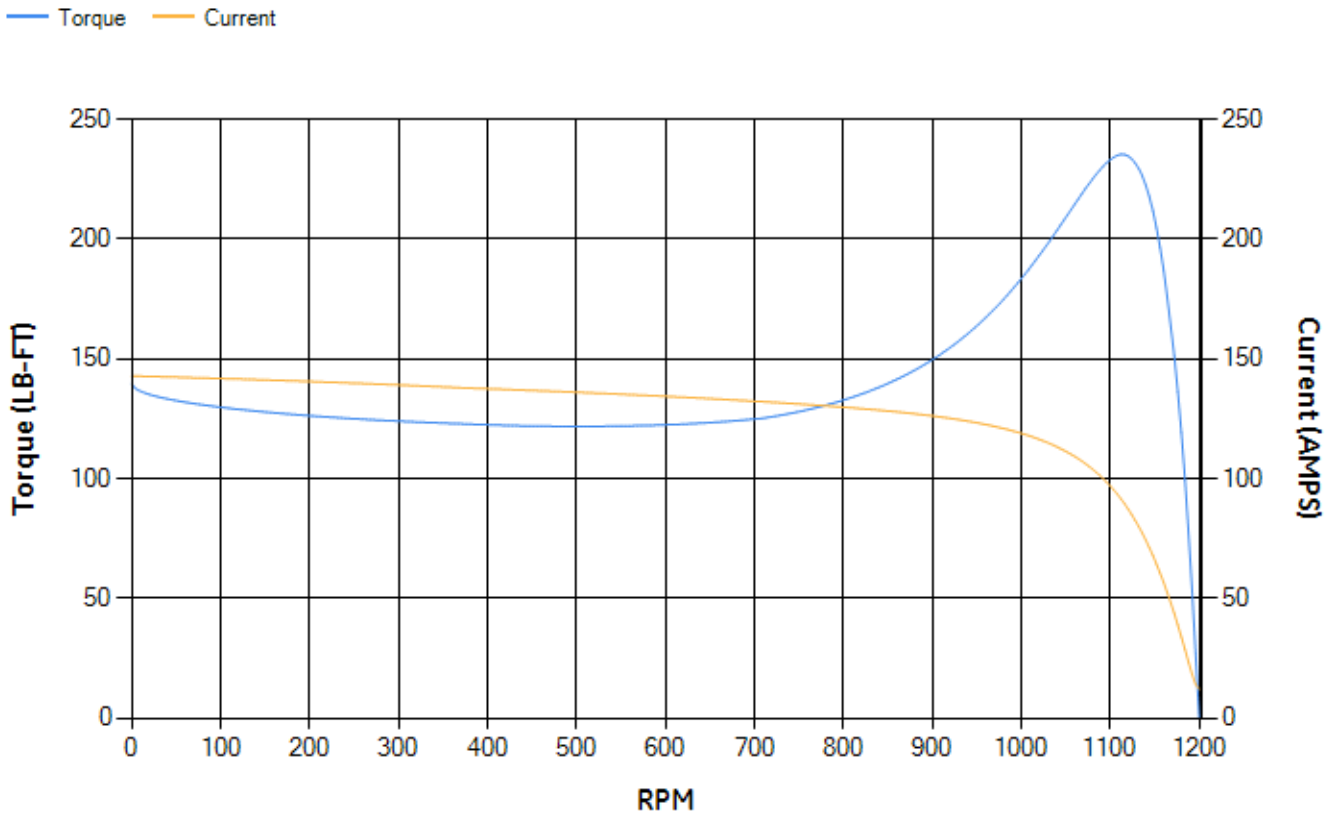

Marks:

NOTE 1: CONDUIT BOX MAY BE ASSEMBLED WITH ENTRANCE UP, DOWN OR TO EITHER SIDE.
 NOTE 2: F1 ASSEMBLY AS SHOWN. F2 ASSEMBLY CONDUIT BOX ON OPPOSITE SIDE FROM SHOWN LOCATION.
 NOTE 3: MOUNTING SURFACES WILL BE SQUARE AND CONCENTRIC WITH SHAFT WITHIN .004 T.I.R.
 NOTE 4: SHAFT RUNOUT WILL NOT EXCEED .002 T.I.R.

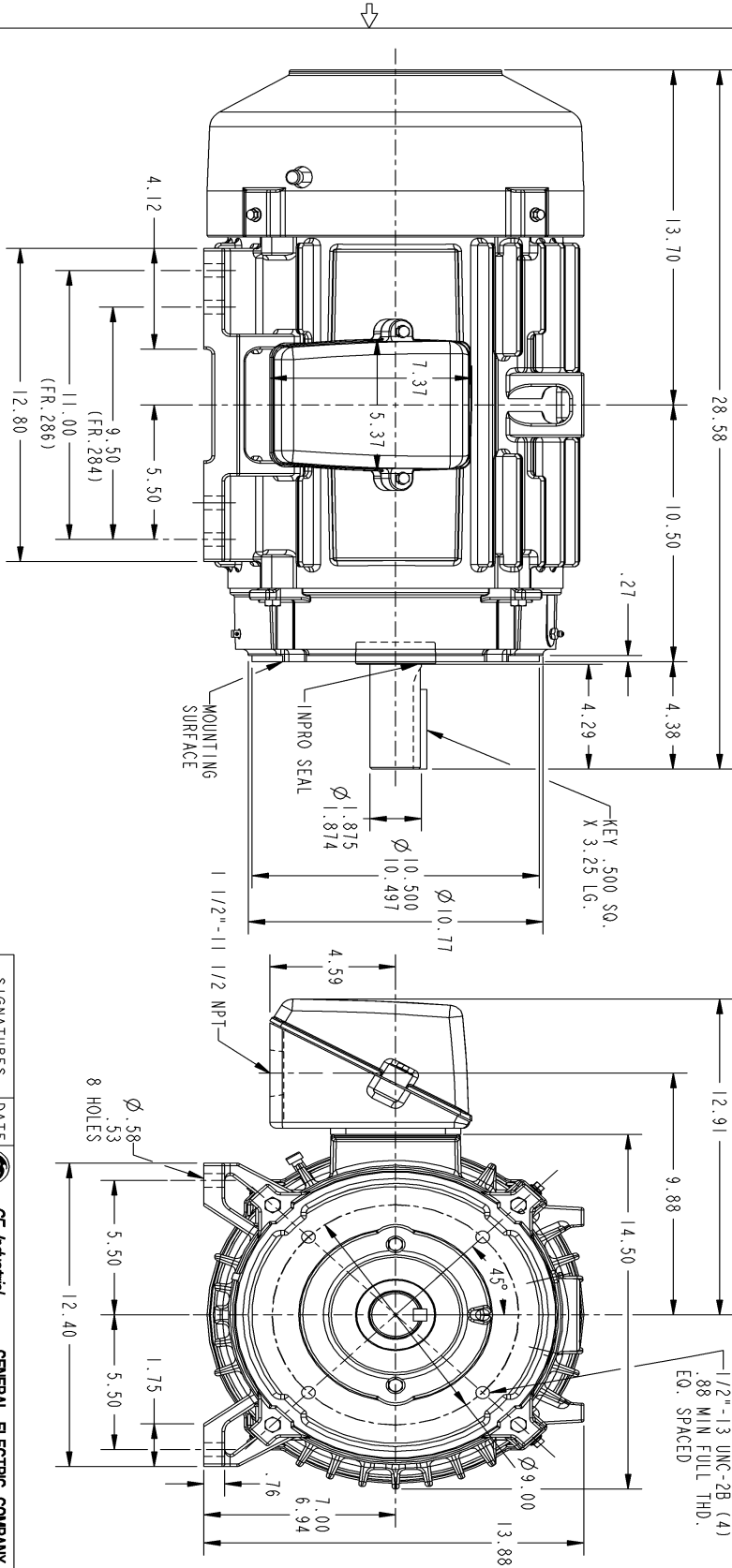

SIZE B 4002B5828PBP5316

SM 0

REV.	DESCRIPTION	DATE	APPROVED

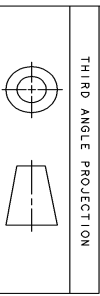

SIGNATURES	DATE	REV
DRWN: N PRAJSD	11/05/06	0
CHEK: BMT HMR	11/05/06	
ISSD: N PRAJSD	11/05/06	

APPLIED PRACTICES: B

SCALE: 0.250 REF. NO.: 4002B5828PBP5201 SHEET 1 OF 1

GE Industrial Systems
GENERAL ELECTRIC COMPANY
 Fort Wayne, Indiana

INDUCTION MOTOR OUTLINE
 "C" FACE AT DE WITH INPROSEAL
 FMR: KS284TC TFC "C" FACE 1050° RABBERT

SIZE DRAWING: 4002B5828PBP5316

DISTRIBUTION: PMP-18K15

Marks:

Connection Diagram
GEM2034E-FIG7

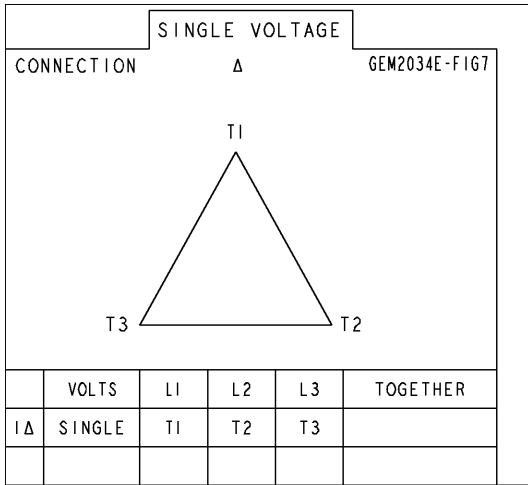

End shield Assembly		
Part Description	DE Side Part#	ODE Side Part#
End Shield	128D6206PM1	4004D5284SE1
Bearing	235A2608AA01	235A2608AA01
Slinger/Inproseal	235A4575GC7	149C4399G03

Fan & Fan Cover Assembly	
Part Description	Part#
Fan	159C6900G01
Fan Cover	4003C5789PA1

Conduit & Accessories Box Assembly	
Part Description	Part#
Conduit Box	4002B5728PA-G01

Mechanical Accessories	
Part Description	Part#
Brake	
Tachometer	