

CATALOG NO. CD0208	OUTLINE DIMENSIONS 3-PHASE INDUCTION MOTOR	MOTOR TYPE: AEEAGD
DATE JULY-12-15		FRAME NO. 324T

Pole	HP	kW	Hz	VOLT	r/min(rpm)
8	20	15	60	230/460	900

Ins	Rating	Dimension in	Approx Weight	Bearings	
F	CONT.	inches	557 lbs.	DE: 6312	NDE: 6212

Totally Enclosed Fan-Cooled Type, Squirrel-Cage Rotor.

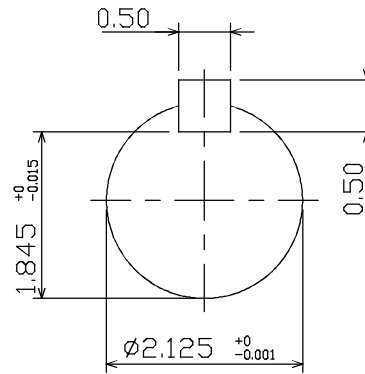
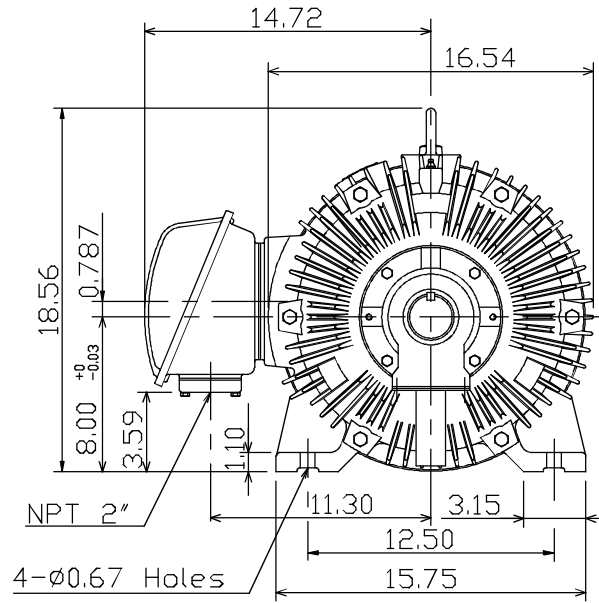
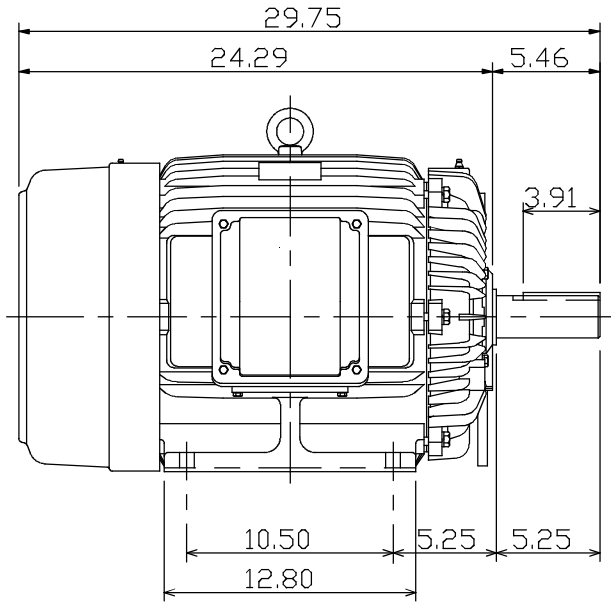

NOTE:

1. ENCLOSURE: IP55
2. SHAFT MATERIAL: SCM440 Q&T (AISI 4140 EQUIV)
3. WITH THERMISTOR: PTC 140°C × 3PCS
WIRED IN MAIN TERMINAL BOX

TW-36C

◇	DWG. C. RAM	07 12 15
---	-------------	----------

DWG.	J.S.LIN	06.15.13	TEC Westinghouse	DWG NO.	31057H257550
CHKD.	K.L.KUD	06.15.13			
APPD.	C.H.SHYU	06.15.13			