

DATE
JULY 11, 2005
CATALOG NO.
G0/32

OUTLINE DIMENSIONS
3-PHASE INDUCTION MOTOR

MODEL TYPE:
AEGA
FRAME NO. A56

Pole	HP	KW	Hz	VOLT	Syn. Speed R. P. M
2	1/3		60	230/460	3600

Ins.	Rating	Dimensions in	Approx Weight	Bearings
F	CONT.	inch	16.36 lbs	DE: 6205ZZ NDE: 6204ZZ

Totally Enclosed Fan Cooled
Squirrel-Cage

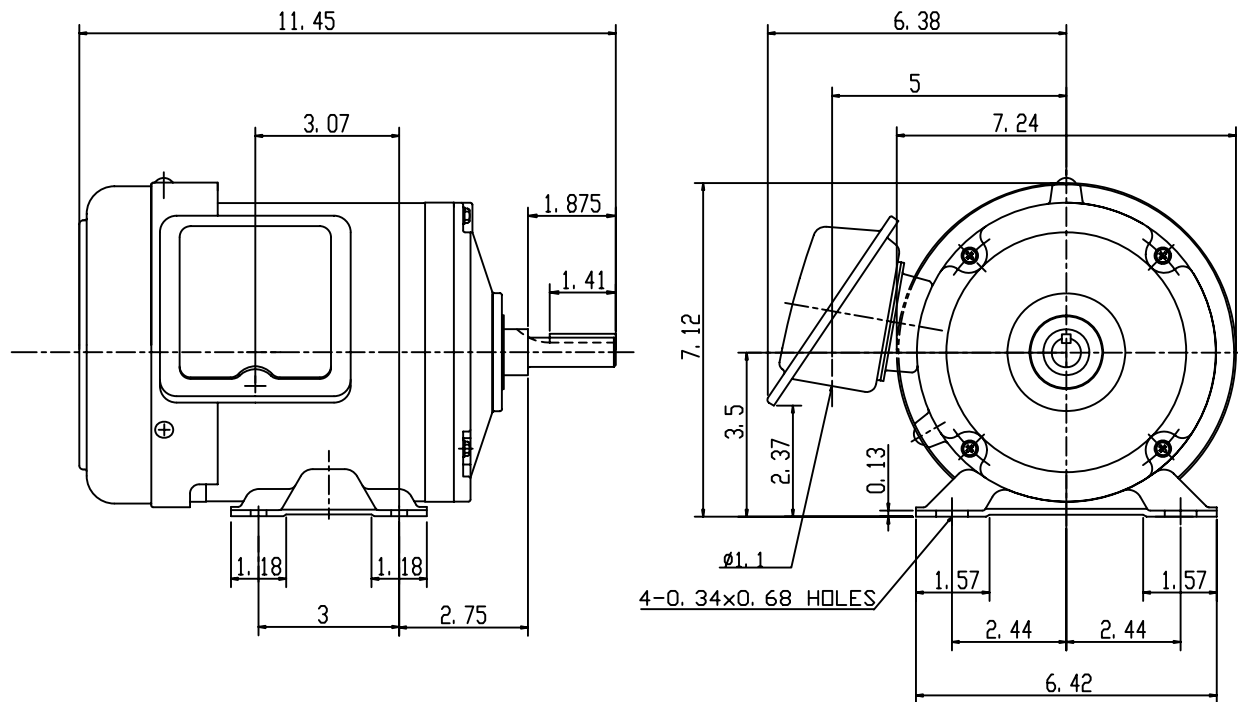

SCALE 4: 1

APPD.	W. H. TSAI	07 21 03
CHKD.	J. B. CHEN	07 20 03
DWN.	Y. Y. CHEN	07 20 03



DWG NO.
31049Z105
2166