

DATE
JULY 15, 2013
CATALOG NO.
XP0508

OUTLINE DIMENSIONS
3-PHASE INDUCTION MOTOR

MOTOR TYPE:
AEHHXU
FRAME NO. 404T

Pole	HP	KW	Hz	VOLT	RPM
8	50	37.3	60	230/460	900

Ins	Rating	Dimension in	Approx Weight	Bearings	
F	CONT.	inches	1287 lbs.	DE: 6317	NDE: 6313

Totally Enclosed Fan-Cooled Type, Squirrel-cage Rotor.

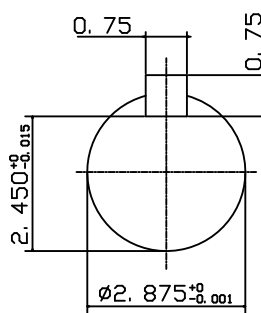
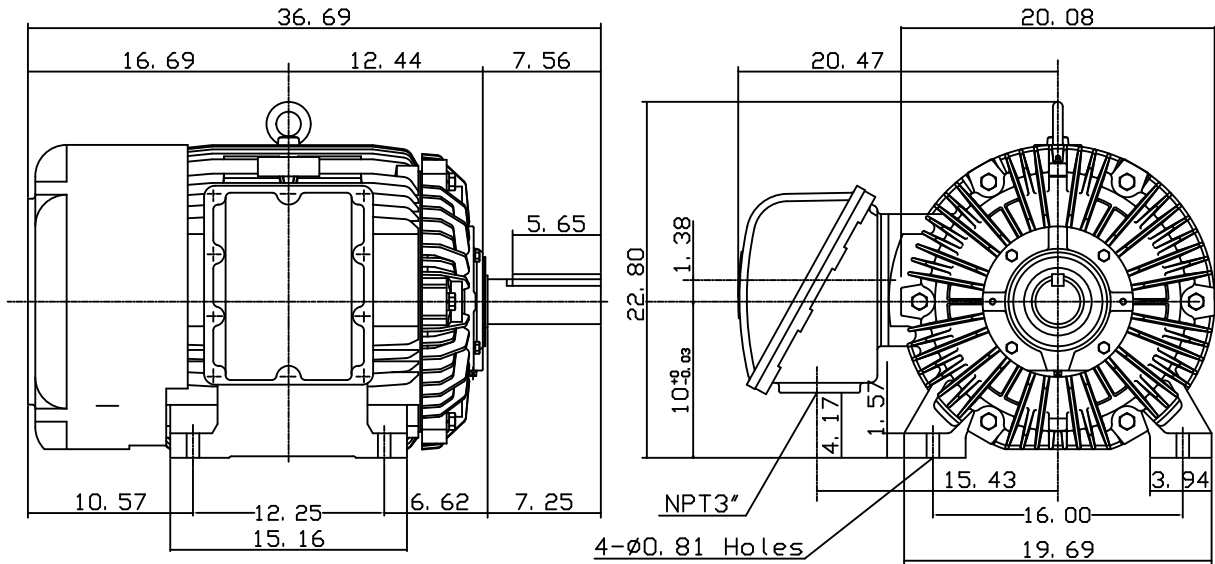

Note:
1. EXPLOSION-PROOF:
CLASS I GROUP D AND
CLASS II GROUP E,F,G.

Note:
1. EXPLOSION-PROOF:
Class I GROUP D AND
CLASS II GROUP E,F,G.

WC0293-1

DWN.	G. L. GUD	06-19-00
CHKD.	C. H. KAD	06-22-00
APPD.	Y. B. HUANG	06-22-00



DWG NO.
31049M633050