

Product Information Packet

November 8, 2016

Data shown is for the current revision model #. Ensure your nameplate model # matches.

Model Number:	5KS254SAA104D1
Catalog Number:	M9741
Instruction Manual:	GEI-56128
Connection Diagram:	GEM2034E-FIG1
Outline Drawing:	4002B5825PAP5201

Accessory Connection Diagrams			
Bearing Thermocouple:	None	Heater:	None
RTD:	None	Thermistor:	None
Thermostat:	None	Winding Thermocouple:	None
Bearing RTD:	None		

Table of Contents

Specification	01
Performance Characteristics	02
Outline Drawing	03
Connection Drawing(s)	04
Spare parts	05



Marks:

MODEL NUMBER:	5KS254SAA104D1	Estimated Weight:	315 Lbs
Outline Drawing:	4002B5825PAP5201	Time Rating:	CONT
Connection Diagram:	GEM2034E-FIG1	Enclosure:	TEFC
Instruction Book:	GEI-56128	Encl Construction:	X\$D
Design Code:	25BD0090B	Ambient Max(°C):	40
Type:	KS	Alt Ambient Max(°C):	65
Frame:	254T	Insulation Class:	H
Phases:	3	NEMA Design:	B
Poles:	2	Nominal Efficiency:	91 %
Output Power:	15HP 11.1KW	Guaranteed Efficiency:	90.2
RPM:	3550	3/4 Load Efficiency:	91.8
Voltage:	575	KVA Code:	G
Hertz:	60	Max KVAR:	2.9
Amps - FL:	13.9	Power Factor:	89.0
Service Factor:	1.25	Bearing - DE:	6309ZC3
Alt Service Factor:	1.00	Bearing - ODE:	6309ZC3

Enclosure is Totally Enclosed Fan-Cooled

Stamped Nameplate Notes:

SF AMPS 17.7
 STAMP NP249A5564P051 AS BELOW:
 MODEL:5KS254SAA104D1 S/N: XXX
 CSA CERTIFIED CSA09.2216219 FOR EX NA IIC 200C GC
 CL 1 ZONE2 AEX NA IIC 200C;CL 1 DIV2 GRP ABCD 200C
 IN -40C <= AMB <= 40C, 1.0 SF ON SINE-WAVE PWR
 SURF TEMP 280C AT 1.25SF ON SINE-WAVE PWR
 OR 200 C VT OR 215 C CT OR 200 C CHP PWM CONTROL
 ALTERNATE RATING FOR PWM CONTROL 1.0SF 40C AMB
 VT 0-60 HZ, CT 3-60 HZ , CHP 60-90 HZ.

Additional Information:

2P - T EXTN
 STANDARD FLOOR MOUNT
 C/BOX 137 CU IN-1.25 NPT
 F1 CONDUIT BOX MOUNTING
 OIL RESISTANT SLEEVING ON LEADS

Performance Characteristics

1st Winding 1st Connection

Design: 25BD0090B

Marks:

LOAD %	125.0	115.0	100.0	75.0	50.0	25.0	0.0
% EFF	89.41	90.08	91.1	91.78	91.66	88.38	0.00
% PF	88.67	89.04	89.2	88.1	83.48	67.11	9.45
AMPS	17.71	16.1	13.82	10.42	7.34	4.73	3.28

TORQ(FL)#FT	22.19	TORQ(LR)%FL	185.05	TORQ(BD)%FL	263.8
AMPS(LR)	88.3	PF AT START	0.3		

This motor is capable of two cold or one hot start with a maximum connected load inertia of 100 Lb-Ft Sq (4.21 Kg-meter Sq) at 100% voltage, where the load torque varies with the square of the speed. Acceleration time with maximum inertia and the above load type is 45 seconds. Safe stall time at 100% voltage is 93 seconds cold, 59 seconds hot. Rotor inertia is 1.05 Lb-Ft Sq (0.04 Kg-meter Sq).

Open Circuit A-C:	0.836	Short Circuit D-C:	0.012
Short Circuit A-C:	0.031	X/R Ratio:	4.631
Stator Slots:	36	Rotor Slots:	26

Speed Torque Current Curve (First Connection, First Speed)

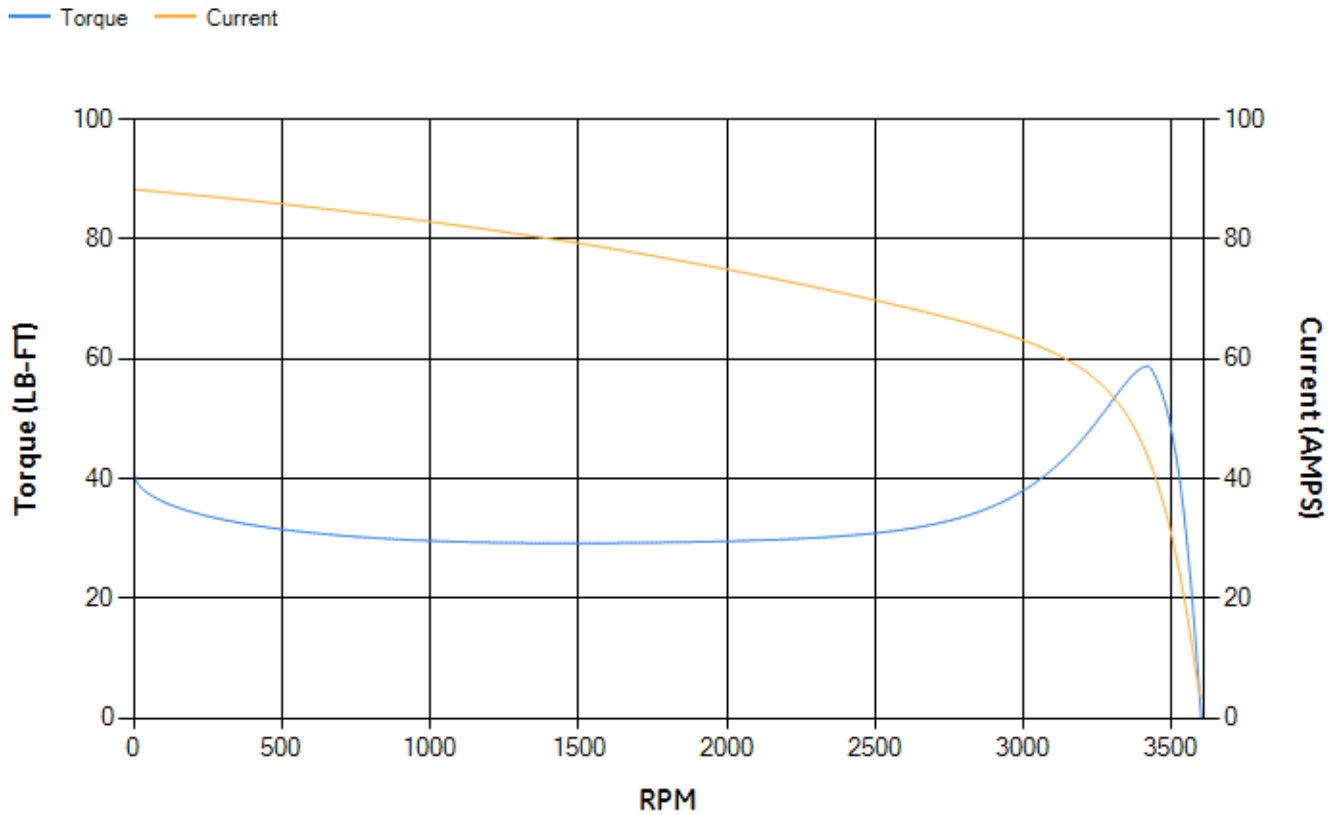

Marks:

NOTE 1: CONDUIT BOX MAY BE ASSEMBLED WITH ENTRANCE UP, DOWN OR TO EITHER SIDE.
 NOTE 2: F1 ASSEMBLY AS SHOWN. F2 ASSEMBLY CONDUIT BOX ON OPPOSITE SIDE FROM SHOWN LOCATION.
 NOTE 3: SHAFT RUNOUT WILL NOT EXCEED .002 T.I.R.

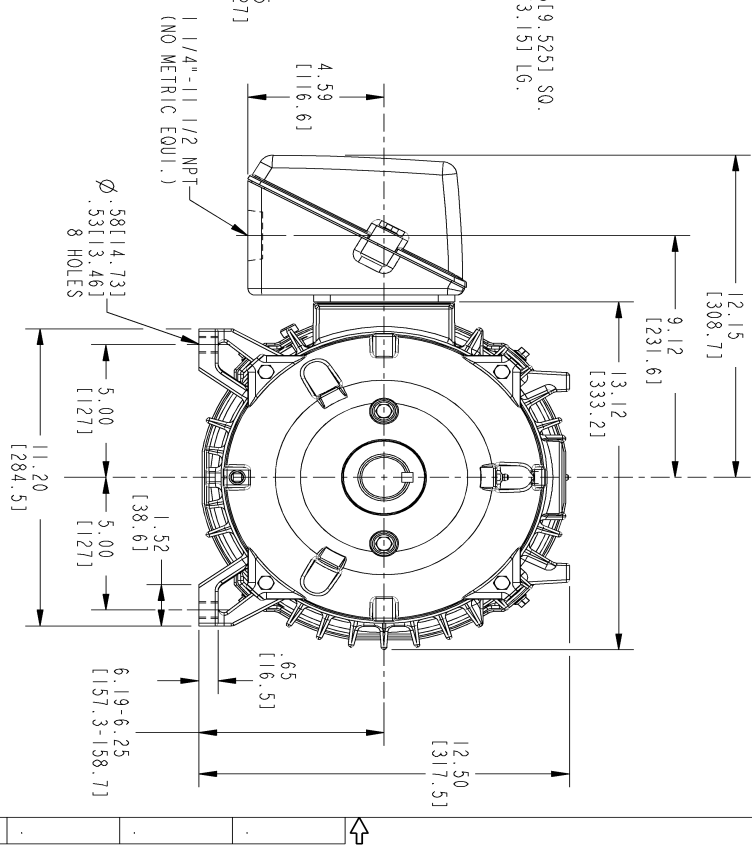
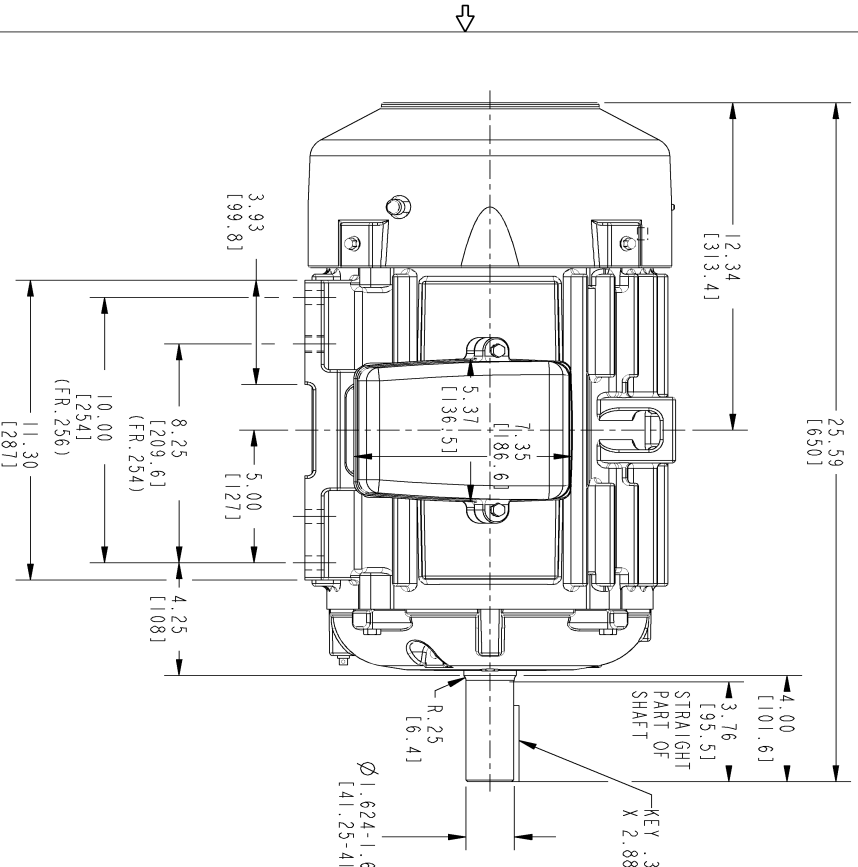

REV.	DESCRIPTION	DATE	APPROVED
1	NOTE X50 ULTRA DELETED	05/20/03	SAJAJAY
2	ISAAC 09-0868	09/29/09	SAVANTHI
3	ISAAC 09-1036	12/02/09	RAGHU
4	ISSAC 12-0025	01/09/11	RAGHU

SIZE B DRAWING NO. 4002B5825PAP5201 SH 4 REV

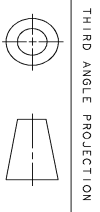

SIGNATURES	DATE	APPROVED
DRAWN: GARY WARRNER	JAN 16/02	<p>GENERAL ELECTRIC COMPANY Fort Wayne, Indiana</p> <p>INDUCTION MOTOR OUTLINE STANDARD CONSTRUCTION FMR: FR250T TEEC</p>
CHECKED: GARY WARRNER	JAN 16/02	
ENGR: GARY WARRNER	JAN 16/02	
ISSUED: GARY WARRNER	JAN 16/02	

DISTRIBUTION: PMP-18K15

SCALE: 0.250 REF. NO: 4002B5825PAP201 SHEET 0F 1

Marks:

Connection Diagram
GEM2034E-FIG1



End shield Assembly		
Part Description	DE Side Part#	ODE Side Part#
End Shield	4004D5283PB1	4004D5283SE1
Bearing	235A2607AA01	235A2607AA01
Slinger/Inproseal	149C4399G02	149C4399G02

Fan & Fan Cover Assembly	
Part Description	Part#
Fan	159C6704G02
Fan Cover	4003C5788PA1

Conduit & Accessories Box Assembly	
Part Description	Part#
Conduit Box	4002B5728PA-G04

Mechanical Accessories	
Part Description	Part#
Brake	
Tachometer	