

# Product Information Packet

November 8, 2016

Data shown is for the current revision model #. Ensure your nameplate model # matches.

<b>Model Number:</b>	<b>5KS284XAA208D3</b>
<b>Catalog Number:</b>	<b>M9443</b>
<b>Instruction Manual:</b>	GEI-56128
<b>Connection Diagram:</b>	GEM2034E-FIG7
<b>Outline Drawing:</b>	4002B5828PAP5311

## Accessory Connection Diagrams

<b>Bearing Thermocouple:</b>	None	<b>Heater:</b>	None
<b>RTD:</b>	None	<b>Thermistor:</b>	None
<b>Thermostat:</b>	None	<b>Winding Thermocouple:</b>	None
<b>Bearing RTD:</b>	None		

## Table of Contents

Specification	01
Performance Characteristics	02
Outline Drawing	03
Connection Drawing(s)	04
Spare parts	05



**Marks:**

<b>MODEL NUMBER:</b>	<b>5KS284XAA208D3</b>	<b>Estimated Weight:</b>	460 Lbs
<b>Outline Drawing:</b>	4002B5828PAP5311	<b>Time Rating:</b>	CONT
<b>Connection Diagram:</b>	GEM2034E-FIG7	<b>Enclosure:</b>	TEFC
<b>Instruction Book:</b>	GEI-56128	<b>Encl Construction:</b>	841
<b>Design Code:</b>	28BD1162A	<b>Ambient Max(°C):</b>	40
<b>Type:</b>	KS	<b>Alt Ambient Max(°C):</b>	--
<b>Frame:</b>	284T	<b>Insulation Class:</b>	H
<b>Phases:</b>	3	<b>NEMA Design:</b>	B
<b>Poles:</b>	4	<b>Nominal Efficiency:</b>	93.6 %
<b>Output Power:</b>	25HP 18.5KW	<b>Guaranteed Efficiency:</b>	93.0
<b>RPM:</b>	1780	<b>3/4 Load Efficiency:</b>	94.1
<b>Voltage:</b>	460	<b>KVA Code:</b>	G
<b>Hertz:</b>	60	<b>Max KVAR:</b>	7.0
<b>Amps - FL:</b>	29.1	<b>Power Factor:</b>	86.0
<b>Service Factor:</b>	1.15	<b>Bearing - DE:</b>	6310ZC3
<b>Alt Service Factor:</b>	--	<b>Bearing - ODE:</b>	6310ZC3

**Enclosure is Totally Enclosed Fan-Cooled**

**Stamped Nameplate Notes:**

IEEE-STD-841-2009  
 DE BRG 50BC03JP30 ODE BRG 50BC03JP30  
 STAMP NP249A5564P051 AS BELOW:  
 MODEL:5KS284XAA208D3 S/N: XXX  
 CSA CERTIFIED CSA09.2216219 FOR EX NA IIC 200 C GC  
 CL1ZONE2 AEXNAIIC 200 C; CL1DIV2 GRP ABCD 200 C  
 IN -25C <= AMB <= 40C, 1.0 SF ON SINE-WAVE PWR  
 SURF TEMP 200 C AT 1.15 SF ON SINE-WAVE PWR  
 OR 200 C VT OR 200 C CT OR 200 C CHP PWM CONTROL  
 ALTERNATE RATING FOR PWM CONTROL 1.0 SF 40 C AMB  
 VT 0-60 HZ, CT 3-60 HZ, CHP 60-90 HZ.

**Additional Information:**

4P - T EXTN  
 STANDARD FLOOR MOUNT  
 C/BOX 137 CU IN-1.50 NPT  
 F1 CONDUIT BOX MOUNTING  
 PAINTED FRAME ID & SHAFT,  
 FAN COVER INSIDE & ODE E/S OUTSIDE  
 ROUTINE AND 5 POINT VIBRATION TESTS INCL IN C/BOX  
 INPRO SEAL BOTH ENDS  
 GROUND SCREW ON FRAME  
 SHAFT RUNOUT LIMIT .0015" TIR  
 COPPER WASHER UNDER HEADS OF BEARING CAP BOLTS  
 APPLY TITE-SEAL (A50CD427A) ON BEARING CAP SCREWS, RABBETS,  
 AND PLUG THREADS  
 OIL RESISTANT SLEEVING ON LEADS





**Performance Characteristics**

1st Winding 1st Connection

**Design: 28BD1162A**

**Marks:**

LOAD %	125.0	115.0	100.0	75.0	50.0	25.0	0.0
% EFF	92.52	92.94	93.68	94.08	94.02	91.68	0.00
% PF	86.96	86.73	85.92	82.68	74.44	52.93	4.42
AMPS	36.35	33.38	29.05	22.56	16.72	12.05	9.8

<b>TORQ(FL)#FT</b>	73.83	<b>TORQ(LR)%FL</b>	181.28	<b>TORQ(BD)%FL</b>	286.96
<b>AMPS(LR)</b>	178.14	<b>PF AT START</b>	0.38		

This motor is capable of two cold or one hot start with a maximum connected load inertia of 887 Lb-Ft Sq (37.34 Kg-meter Sq) at 100% voltage, where the load torque varies with the square of the speed. Acceleration time with maximum inertia and the above load type is 56 seconds. Safe stall time at 100% voltage is 100 seconds cold, 67 seconds hot. Rotor inertia is 4.93 Lb-Ft Sq (0.21 Kg-meter Sq).

<b>Open Circuit A-C:</b>	0.627	<b>Short Circuit D-C:</b>	0.016
<b>Short Circuit A-C:</b>	0.028	<b>X/R Ratio:</b>	5.887
<b>Stator Slots:</b>	48	<b>Rotor Slots:</b>	40

**Speed Torque Current Curve (First Connection, First Speed)**

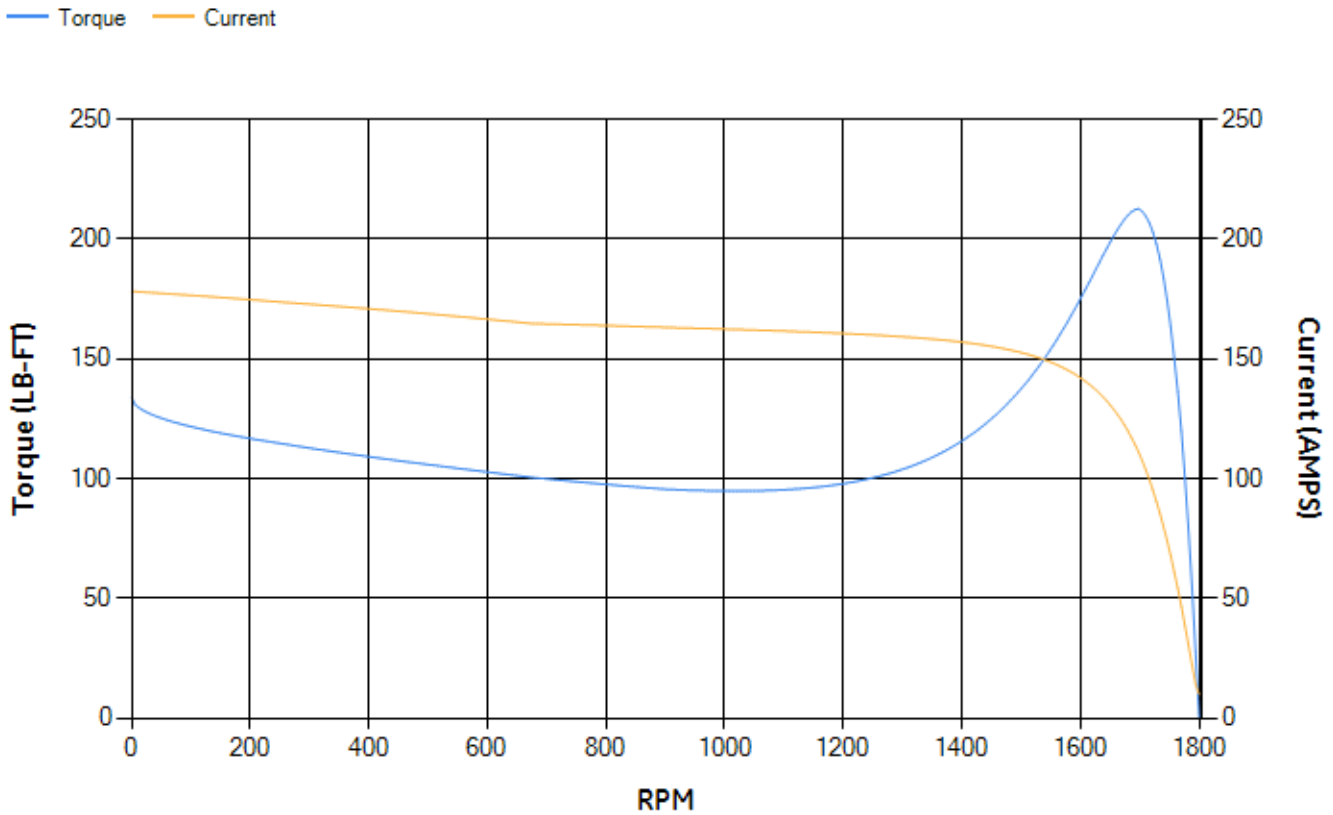

Marks:

NOTE 1: CONDUIT BOX MAY BE ASSEMBLED WITH ENTRANCE UP, DOWN OR TO EITHER SIDE.  
 NOTE 2: F1 ASSEMBLY AS SHOWN. F2 ASSEMBLY CONDUIT BOX ON OPPOSITE SIDE FROM SHOWN LOCATION.  
 NOTE 3: SHAFT RUNOUT WILL NOT EXCEED .0015 T.I.R.  
 NOTE 4: ALL DIMENSIONS ARE IN INCHES. BRACKETED DIMENSIONS ARE IN METRIC (MILLIMETERS).

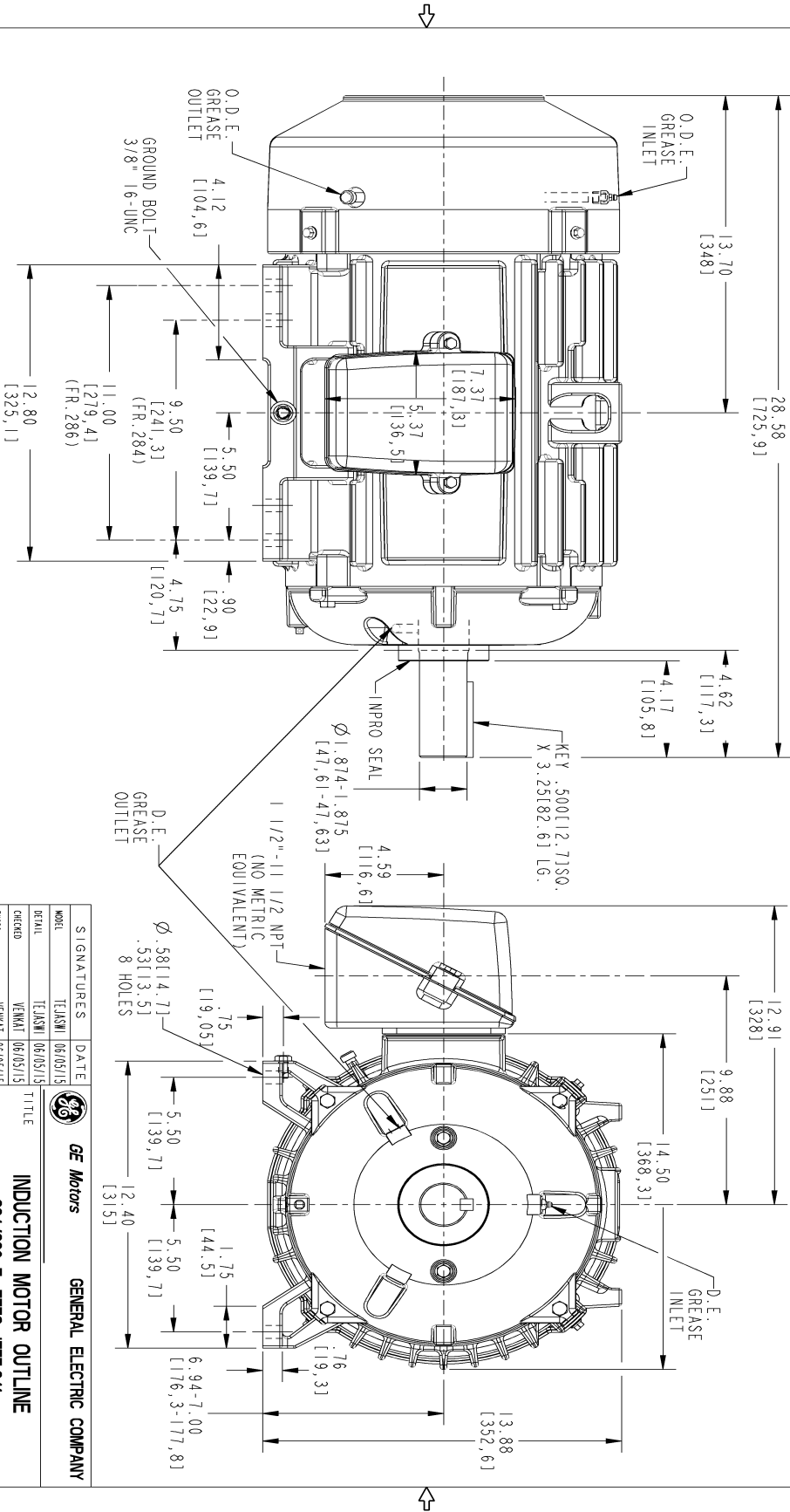

SIZE	DRAWING NO.	REV	SHEET
B	4002B5828PAP5311	0	1

REVISIONS			
REV.	DESCRIPTION	DATE	APPROVED

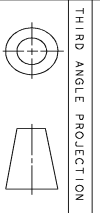

SIGNATURES		DATE	
MODEL	TEJASWI	06/05/15	
DETAIL	TEJASWI	06/05/15	
CHECKED	VENKAT	06/05/15	
ENGR	VENKAT	06/05/15	
QUALITY	TEJASWI	06/05/15	
ISSUED			
SOLID MODEL: 4002B5828PAP5311			

**GE Motors**  
 GENERAL ELECTRIC COMPANY

**INDUCTION MOTOR OUTLINE**  
 284/286 T, TEFC, IEEE-841

**CBOX 137 CUL - 150 NPT, IMPRO SEAL, GROUND PAD**  
 4002B5828PAP5311

SCALE: 0.250 REF. No.: 4002B5828PAP5301 SHEET 1 of 1

Marks:

**Connection Diagram**  
**GEM2034E-FIG7**



End shield Assembly		
Part Description	DE Side Part#	ODE Side Part#
End Shield	4004D5284PB1	4004D5284SE1
Bearing	235A2608AA01	235A2608AA01
Slinger/Inproseal	4002B5914AF5	4002B5914AG5

Fan & Fan Cover Assembly	
Part Description	Part#
Fan	159C6700G02
Fan Cover	4003C5789PA1

Conduit & Accessories Box Assembly	
Part Description	Part#
Conduit Box	4002B5728PA-G01

Mechanical Accessories	
Part Description	Part#
Brake	
Tachometer	