

Product Information Packet

November 9, 2016

Data shown is for the current revision model #. Ensure your nameplate model # matches.

Model Number:	5KS445SAA304D6
Catalog Number:	M9870
Instruction Manual:	GEI-56128
Connection Diagram:	GEM2034E-FIG7
Outline Drawing:	239C6600AA

Accessory Connection Diagrams			
Bearing Thermocouple:	None	Heater:	None
RTD:	None	Thermistor:	None
Thermostat:	None	Winding Thermocouple:	None
Bearing RTD:	None		

Table of Contents

Specification	01
Performance Characteristics	02
Outline Drawing	03
Connection Drawing(s)	04
Spare parts	05



Marks:

MODEL NUMBER:	5KS445SAA304D6	Estimated Weight:	2040 Lbs
Outline Drawing:	239C6600AA	Time Rating:	CONT
Connection Diagram:	GEM2034E-FIG7	Enclosure:	TEFC
Instruction Book:	GEI-56128	Encl Construction:	X\$D
Design Code:	44BD3089B	Ambient Max(°C):	40
Type:	KS	Alt Ambient Max(°C):	65
Frame:	445T	Insulation Class:	H
Phases:	3	NEMA Design:	B
Poles:	6	Nominal Efficiency:	95.0 %
Output Power:	125HP 92.5KW	Guaranteed Efficiency:	94.5
RPM:	1190	3/4 Load Efficiency:	95.5
Voltage:	575	KVA Code:	G
Hertz:	60	Max KVAR:	42.6
Amps - FL:	120.0	Power Factor:	82.0
Service Factor:	1.25	Bearing - DE:	6318ZC3
Alt Service Factor:	1.00	Bearing - ODE:	6318ZC3

Enclosure is Totally Enclosed Fan-Cooled

Stamped Nameplate Notes:

SF AMPS 147.3
 STAMP NP249A5564P051 AS BELOW:
 MODEL:5KS445SAA304D6 S/N: XXX
 CSA CERTIFIED CSA09.2216219 FOR EX NA IIC 200 C GC
 CL 1 ZONE2 AEX NA IIC 200C;CL 1 DIV2 GRP ABCD 200C
 IN -40C <= AMB <= 40C, 1.0 SF ON SINE-WAVE PWR
 SURF TEMP 260C AT 1.25SF ON SINE-WAVE PWR
 OR 200C VT OR 230C CT OR 200C CHP PWM CONTROL
 ALTERNATE RATING FOR PWM CONTROL 1.0SF 40C AMB
 VT 0-60 HZ, CT 15-60 HZ, CHP 60-90 HZ.

Additional Information:

6P - T EXTN
 C/BOX 700 CU IN - 3.00" NPT
 OIL RESISTANT SLEEVING ON LEADS
 F1 MOUNTING

Performance Characteristics

1st Winding 1st Connection

Design: 44BD3089B

Marks:

LOAD %	125.0	115.0	100.0	75.0	50.0	25.0	0.0
% EFF	94.8	95.02	95.5	95.52	95.17	92.79	0.00
% PF	83.77	83.3	82.06	77.73	67.85	45.49	3.25
AMPS	147.32	135.97	119.43	94.54	72.47	55.43	47.55

TORQ(FL)#FT	550.96	TORQ(LR)%FL	194.21	TORQ(BD)%FL	252.13
AMPS(LR)	730.62	PF AT START	0.35		

This motor is capable of two cold or one hot start with a maximum connected load inertia of 6408 Lb-Ft Sq (269.78 Kg-meter Sq)at 100% voltage, where the load torque varies with the square of the speed. Acceleration time with maximum inertia and the above load type is 38 seconds. Safe stall time at 100% voltage is 77 seconds cold, 46 seconds hot. Rotor inertia is 100.88 Lb-Ft Sq (4.25 Kg-meter Sq).

Open Circuit A-C:	0.862	Short Circuit D-C:	0.026
Short Circuit A-C:	0.051	X/R Ratio:	9.922
Stator Slots:	72	Rotor Slots:	58

Speed Torque Current Curve (First Connection, First Speed)

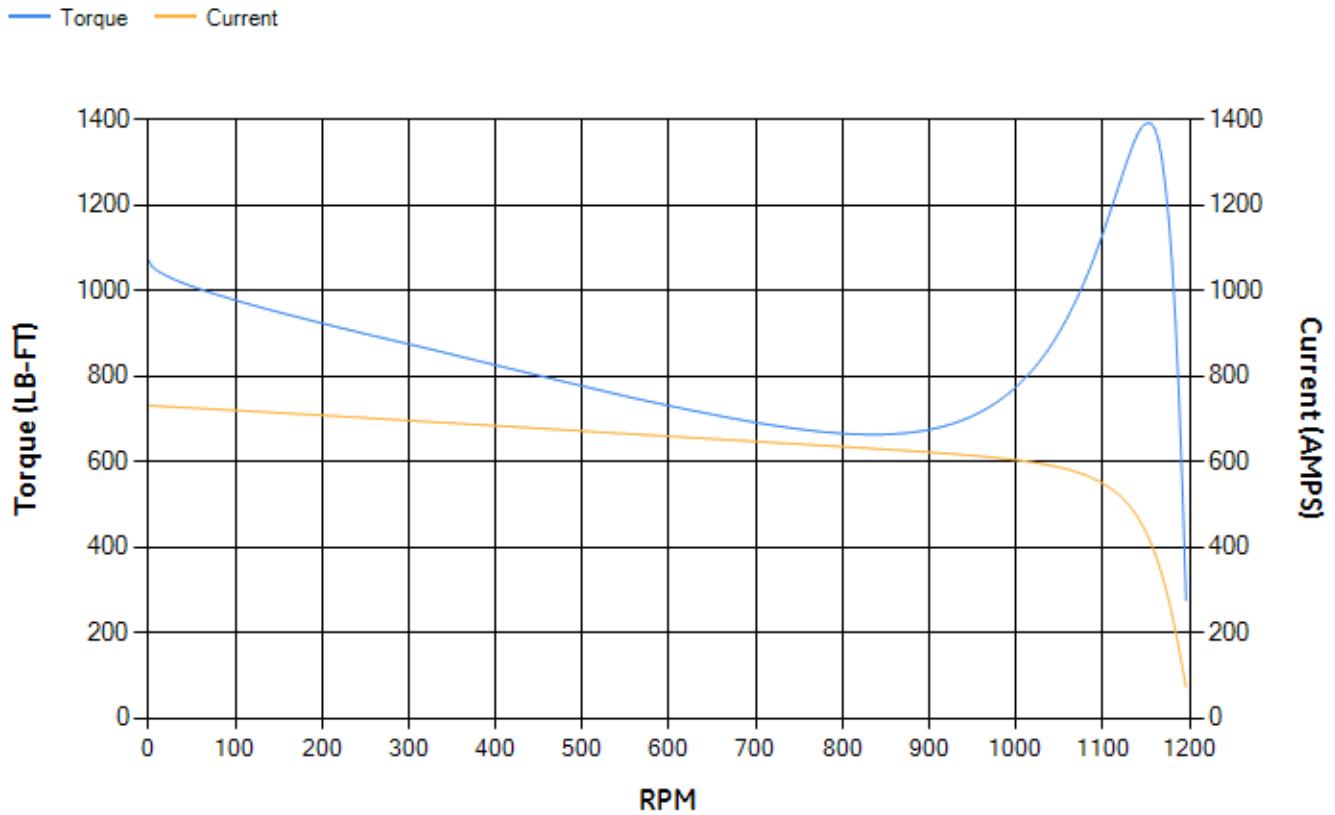

Marks:

REV.	DESCRIPTION	DATE	APPROVED
1	ECH 01-0311	02/05/01	
2	ADDED FAN COVER FIG. CPA	04/30/01	
3	SAC 02-0273 MARGAJ	02/04/02	
4	SAC 03-2024	08/06/03	
5	SAC 13-0248	03/22/13	

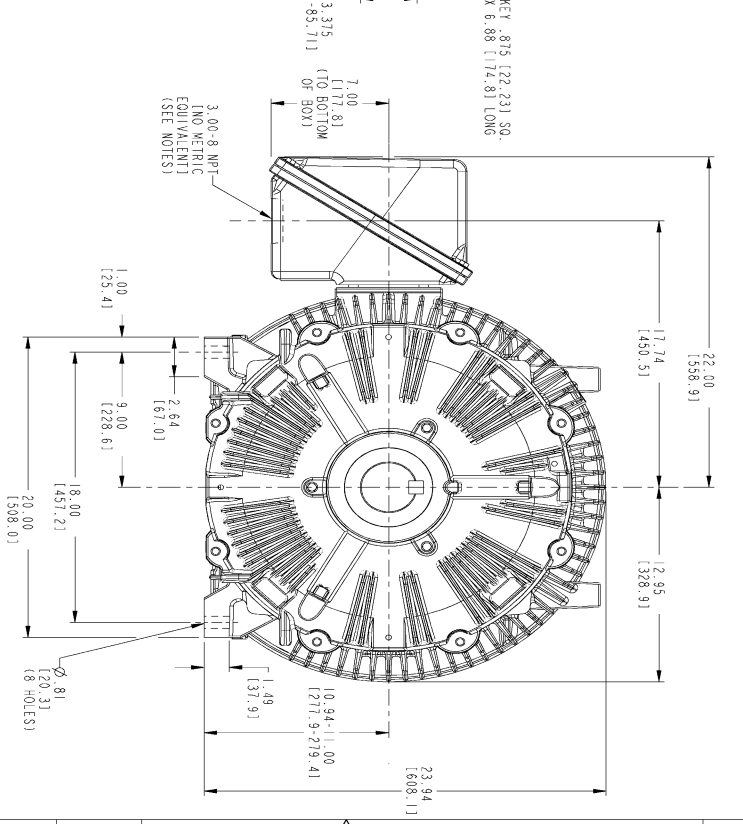
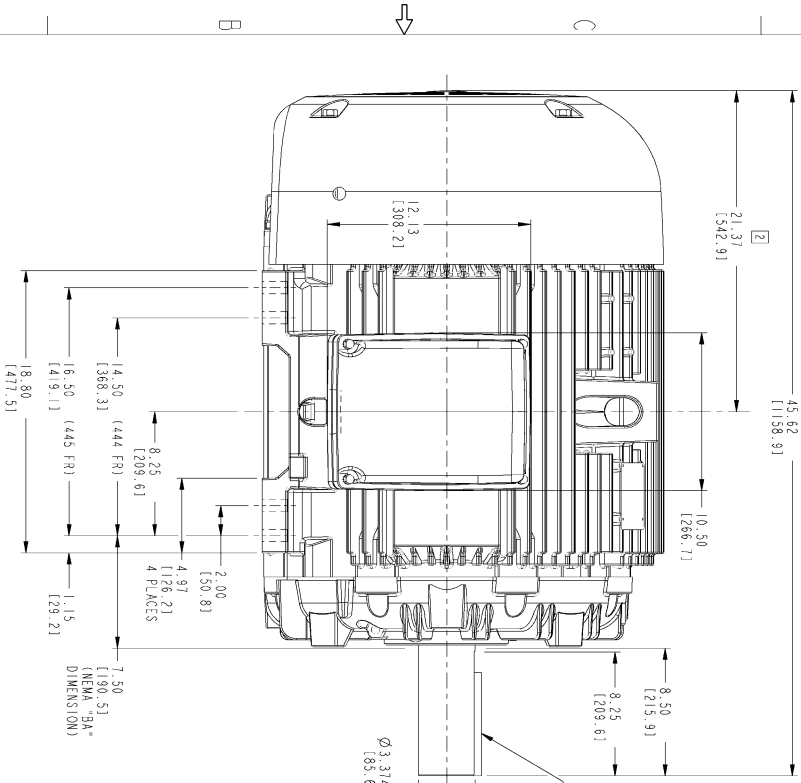

- NOTES:
- CONDUIT BOX MAY BE PLACED WITH THE ENTRANCE DOWN, UP OR ON EITHER SIDE.
 - F-1 ASSEMBLY AS SHOWN.
 - F-2 ASSEMBLY HAS CONDUIT BOX ON OPPOSITE SIDE.
 - BRACKETED DIMENSIONS ARE METRIC (MILLIMETERS).

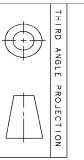

THIRD ANGLE PROJECTION

SIGNATURES	DATE	 GENERAL ELECTRIC COMPANY Fort Wayne, Indiana
J.M. JUREN 04/17/00 W. ELSWORTH 04/17/00 D. STARK 04/17/00 W. ELSWORTH 04/17/00		

APPLIED PRACTICES

SIZE DRAWING

SCALE: 0.200 REF. NO. 239C6600AA

SHEET 1 OF 5

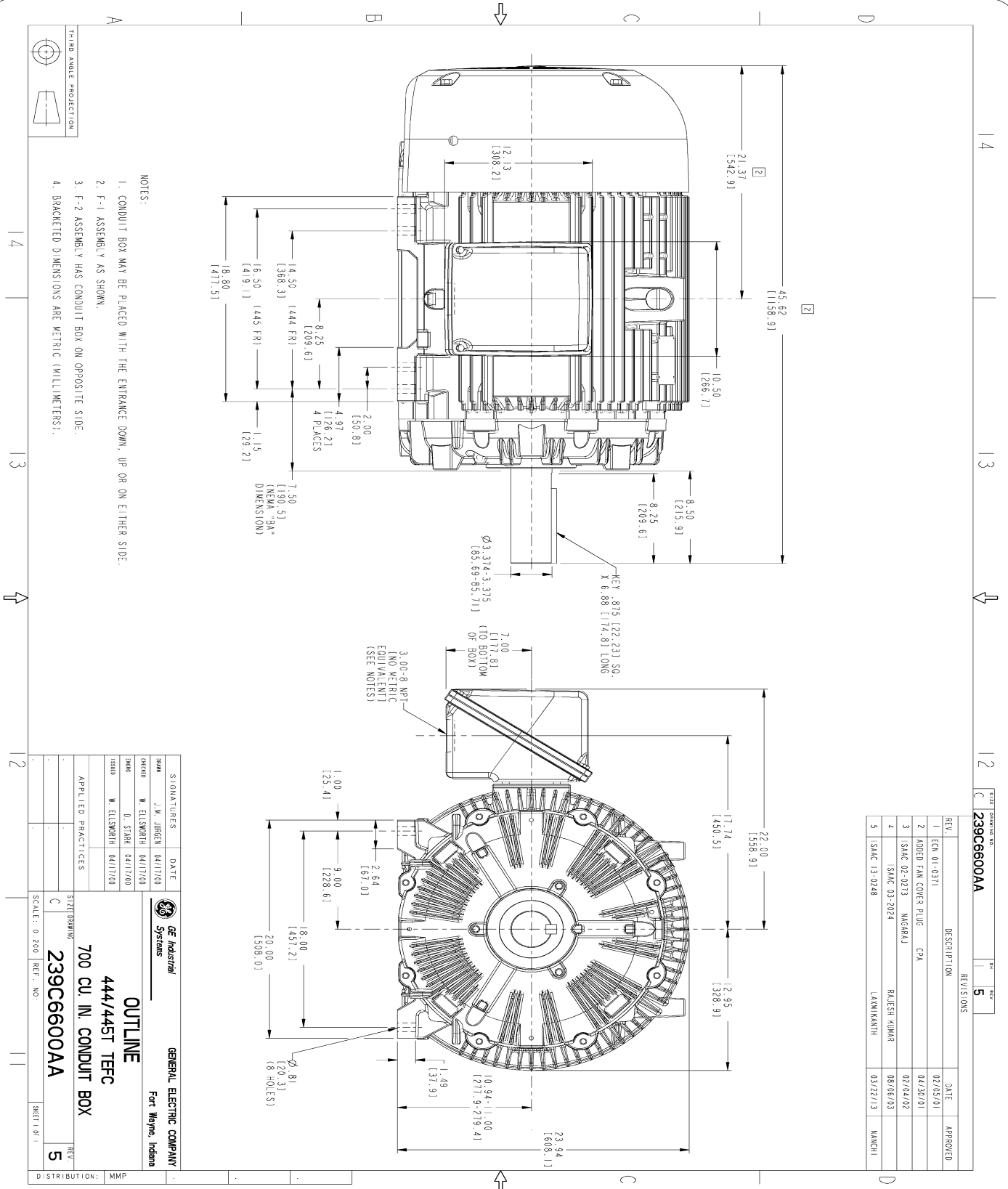

Marks:

Connection Diagram
GEM2034E-FIG7

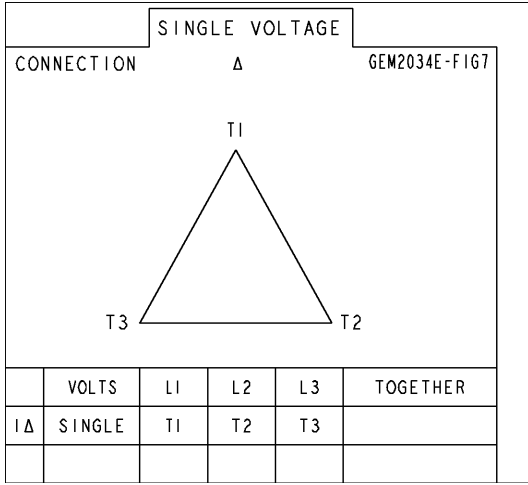

End shield Assembly		
Part Description	DE Side Part#	ODE Side Part#
End Shield	115E4355AA1	115E4355LM1
Bearing	235A2514AG01	235A2514AG01
Slinger/Inproseal	149C4399G07	149C4399G07

Fan & Fan Cover Assembly	
Part Description	Part#
Fan	159C7100G03
Fan Cover	128D6841AA1

Conduit & Accessories Box Assembly	
Part Description	Part#
Conduit Box	118D4408AD2

Mechanical Accessories	
Part Description	Part#
Brake	
Tachometer	