

TYPE	OUTPUT		POLE	TIME RATING	VOLTAGE V	Hz	SYN.SPEED R.P.M
	HP.	kW.					
AEHH8NCF	200	149.2	2	CONT.	460	60	3600

TOTALLY ENCLOSED FAN-COOLED TYPE. SQUIRREL-CAGE ROTOR

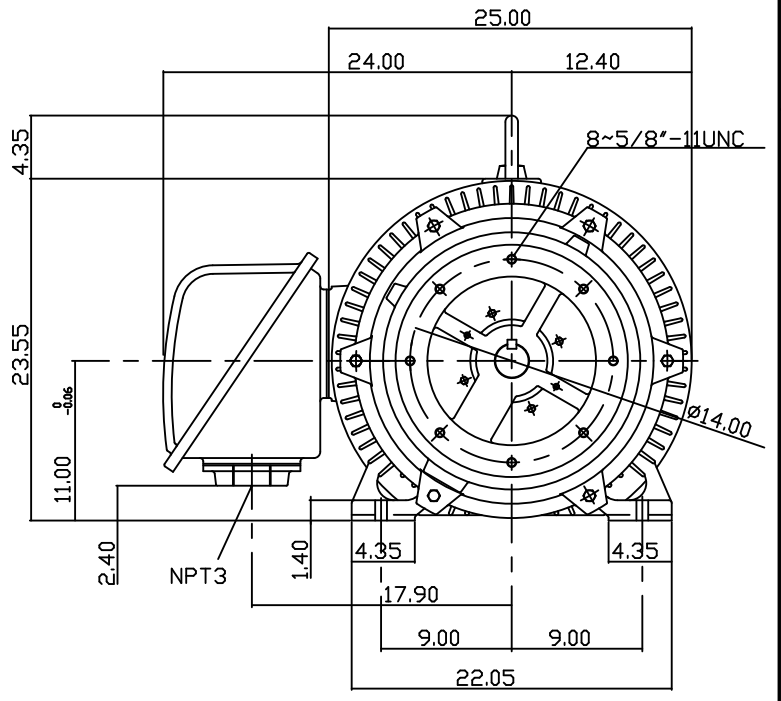
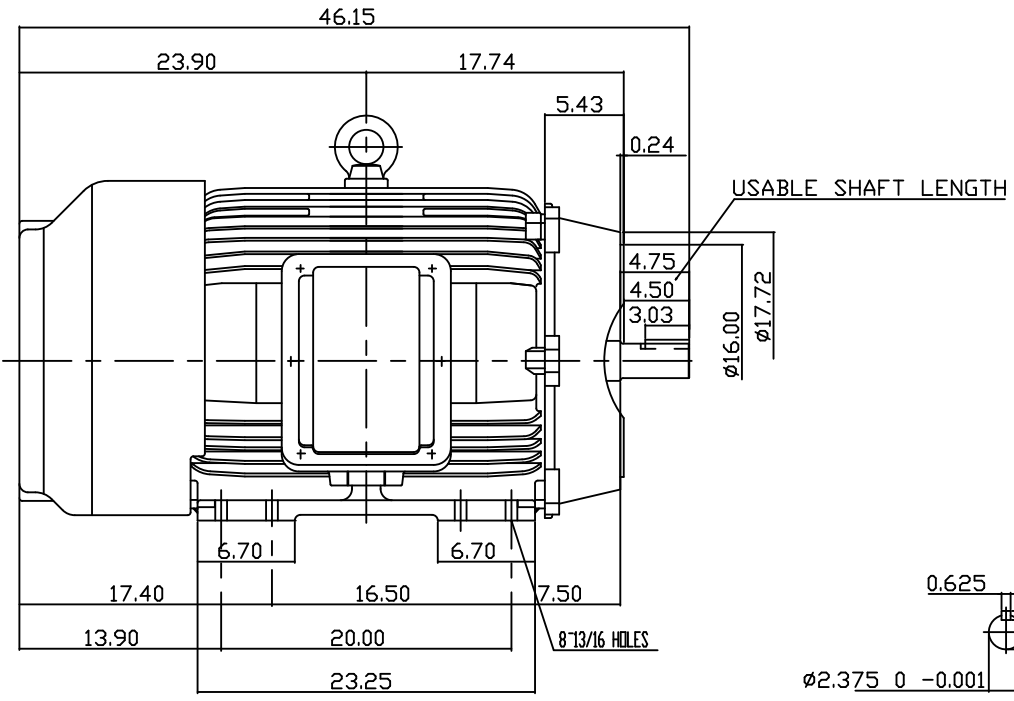

- NOTE:
1. DIMENSIONS IN INCH
  2. FRAME NO. 447TSC
  3. F CLASS INSULATION, S.F.115
  4. FOR DIRECT FLEXIBLE COUPLING
  5. ENCLOSURE: IP54
  6. BEARING SIZE: DRIVE END: 6314C3  
NON-DRIVE END: 6314C3
  7. APPROX. WEIGHT: 2150 LBS

TW-56C

DWN.	Y.ZHU	JAN '06 2006
CHKD.	H.HUANG	JAN '06 2006
APPD.	C.WANG	JAN '06 2006

DATE	MARCH 22, 2013	OUTLINE DIMENSIONS
CATALOG #:	EP2002C	3-PHASE INDUCTION MOTOR
TEC Westinghouse		DWG NO. REV: 00
		3B040C723