

Product Information Packet

November 8, 2016

Data shown is for the current revision model #. Ensure your nameplate model # matches.

Model Number:	5KS284XAA2002D
Catalog Number:	M9519
Instruction Manual:	GEI-56128
Connection Diagram:	GEM2034E-FIG7
Outline Drawing:	4002B5828PDP5310

Accessory Connection Diagrams			
Bearing Thermocouple:	None	Heater:	None
RTD:	None	Thermistor:	None
Thermostat:	None	Winding Thermocouple:	None
Bearing RTD:	None		

Table of Contents

Specification	01
Performance Characteristics	02
Outline Drawing	03
Connection Drawing(s)	04
Spare parts	05



Marks:

MODEL NUMBER:	5KS284XAA2002D	Estimated Weight:	460 Lbs
Outline Drawing:	4002B5828PDP5310	Time Rating:	CONT
Connection Diagram:	GEM2034E-FIG7	Enclosure:	TEFC
Instruction Book:	GEI-56128	Encl Construction:	841
Design Code:	28BD1162A	Ambient Max(°C):	40
Type:	KS	Alt Ambient Max(°C):	--
Frame:	284TC	Insulation Class:	H
Phases:	3	NEMA Design:	B
Poles:	4	Nominal Efficiency:	93.6 %
Output Power:	25HP 18.5KW	Guaranteed Efficiency:	93.0
RPM:	1780	3/4 Load Efficiency:	94.1
Voltage:	460	KVA Code:	G
Hertz:	60	Max KVAR:	7.0
Amps - FL:	29.1	Power Factor:	86.0
Service Factor:	1.15	Bearing - DE:	6310ZC3
Alt Service Factor:	--	Bearing - ODE:	6310ZC3

Enclosure is Totally Enclosed Fan-Cooled

Stamped Nameplate Notes:

IEEE-STD-841-2009
 DE BRG 50BC03JP30 ODE BRG 50BC03JP30
 STAMP NP249A5564P051 AS BELOW:
 MODEL:5KS284XAA2002D S/N: XXX
 CSA CERTIFIED CSA09.2216219 FOR EX NA IIC 200 C GC
 CL1ZONE2 AEXNAIIC 200 C; CL1DIV2 GRP ABCD 200 C
 IN -25C <= AMB <= 40C, 1.0 SF ON SINE-WAVE PWR
 SURF TEMP 200 C AT 1.15 SF ON SINE-WAVE PWR
 OR 200 C VT OR 200 C CT OR 200 C CHP PWM CONTROL
 ALTERNATE RATING FOR PWM CONTROL 1.0 SF 40 C AMB
 VT 0-60 HZ, CT 3-60 HZ, CHP 60-90 HZ.

Additional Information:

4P - T EXTN
 C/BOX 137 CU IN-1.50 NPT
 "C" FACE AT DE ENDSHIELD ROUND FRAME
 VERTICAL MOUNT SHAFT DOWN WITH DRIPCOVER
 PAINTED FRAME ID & SHAFT,
 FAN COVER INSIDE & ODE E/S OUTSIDE
 ROUTINE AND 5 POINT VIBRATION TESTS INCL IN C/BOX
 INPRO SEAL BOTH ENDS
 E/SHLD GROUND STUD MTD ON DE C/BOX SIDE NEAR FOOT
 ROTATE D.E. E/SHIELD 90 DEG. PER OUTLINE
 SHAFT RUNOUT LIMIT .0015" TIR
 COPPER WASHER UNDER HEADS OF BEARING CAP BOLTS
 APPLY TITE-SEAL (A50CD427A) ON BEARING CAP SCREWS, RABBETS,
 AND PLUG THREADS

OIL RESISTANT SLEEVING ON LEADS

Performance Characteristics

1st Winding 1st Connection

Design: 28BD1162A

Marks:

LOAD %	125.0	115.0	100.0	75.0	50.0	25.0	0.0
% EFF	92.52	92.94	93.68	94.08	94.02	91.68	0.00
% PF	86.96	86.73	85.92	82.68	74.44	52.93	4.42
AMPS	36.35	33.38	29.05	22.56	16.72	12.05	9.8

TORQ(FL)#FT	73.83	TORQ(LR)%FL	181.28	TORQ(BD)%FL	286.96
AMPS(LR)	178.14	PF AT START	0.38		

This motor is capable of two cold or one hot start with a maximum connected load inertia of 887 Lb-Ft Sq (37.34 Kg-meter Sq)at 100% voltage, where the load torque varies with the square of the speed. Acceleration time with maximum inertia and the above load type is 56 seconds. Safe stall time at 100% voltage is 100 seconds cold, 67 seconds hot. Rotor inertia is 4.93 Lb-Ft Sq (0.21 Kg-meter Sq).

Open Circuit A-C:	0.627	Short Circuit D-C:	0.016
Short Circuit A-C:	0.028	X/R Ratio:	5.887
Stator Slots:	48	Rotor Slots:	40

Speed Torque Current Curve (First Connection, First Speed)

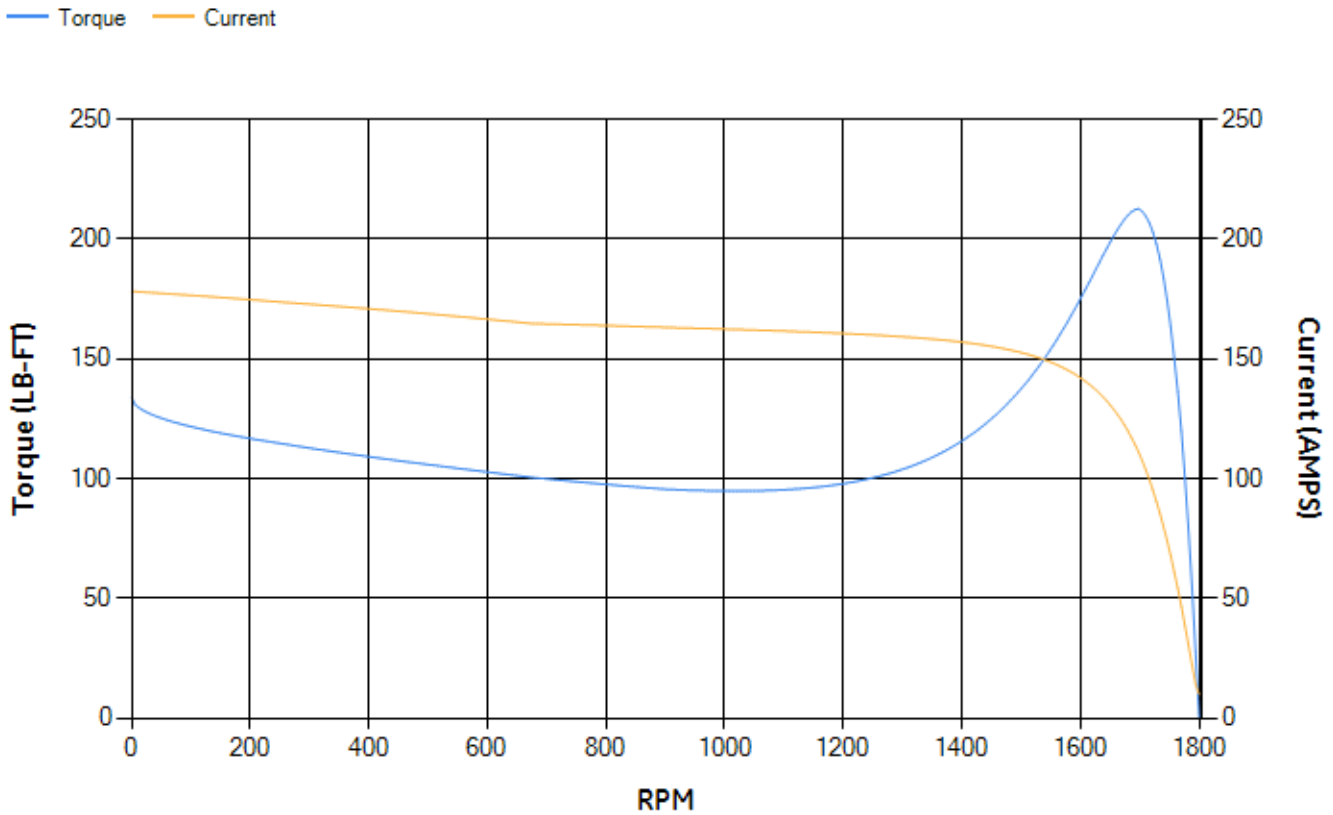

Marks:

- NOTE 1: CONDUIT BOX MAY BE ASSEMBLED WITH ENTRANCE UP, DOWN OR TO EITHER SIDE.
- NOTE 2: F1 ASSEMBLY AS SHOWN. F2 ASSEMBLY CONDUIT BOX ON OPPOSITE SIDE FROM SHOWN LOCATION.
- NOTE 3: MOUNTING SURFACES TO BE SQUARE AND CONCENTRIC WITH SHAFT WITHIN .004 T.I.R.
- NOTE 4: SHAFT RUNOUT WILL NOT EXCEED .0015 T.I.R.
- NOTE 5: DE ENDSHIELD ROTATED 90° COUNTER CLOCKWISE.

GE PROPRIETARY AND CONFIDENTIAL INFORMATION

This document is the property of General Electric Company ("GE") and contains proprietary information of GE. This document is loaned to the recipient for their use in the performance of their duties. It is not to be distributed outside the recipient's organization. The recipient shall be responsible for the protection of this information. This document shall be returned to GE upon its request. This document is not to be copied, reproduced, or otherwise disseminated without the express written consent of GE.

REV.	DESCRIPTION	DATE	APPROVED
1	ISAAC #11-0438	06/27/11	T VIJAYA KUMAR
2	ISAAC # 15-0485	05/14/2015	V. JAY
3	ISAAC#15-1066	11/03/15	HAREHARAN

SIZE DRAWING NO. **B** 4002B5828PDP5310 3

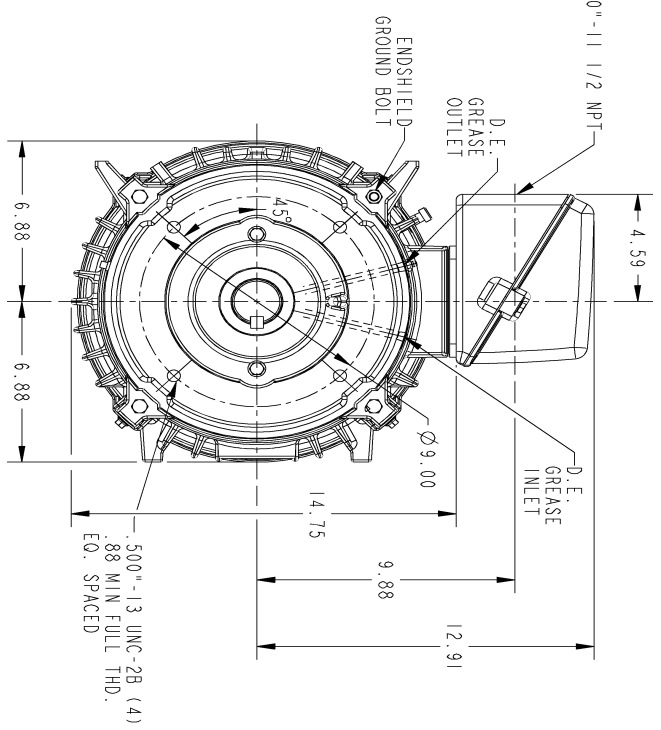
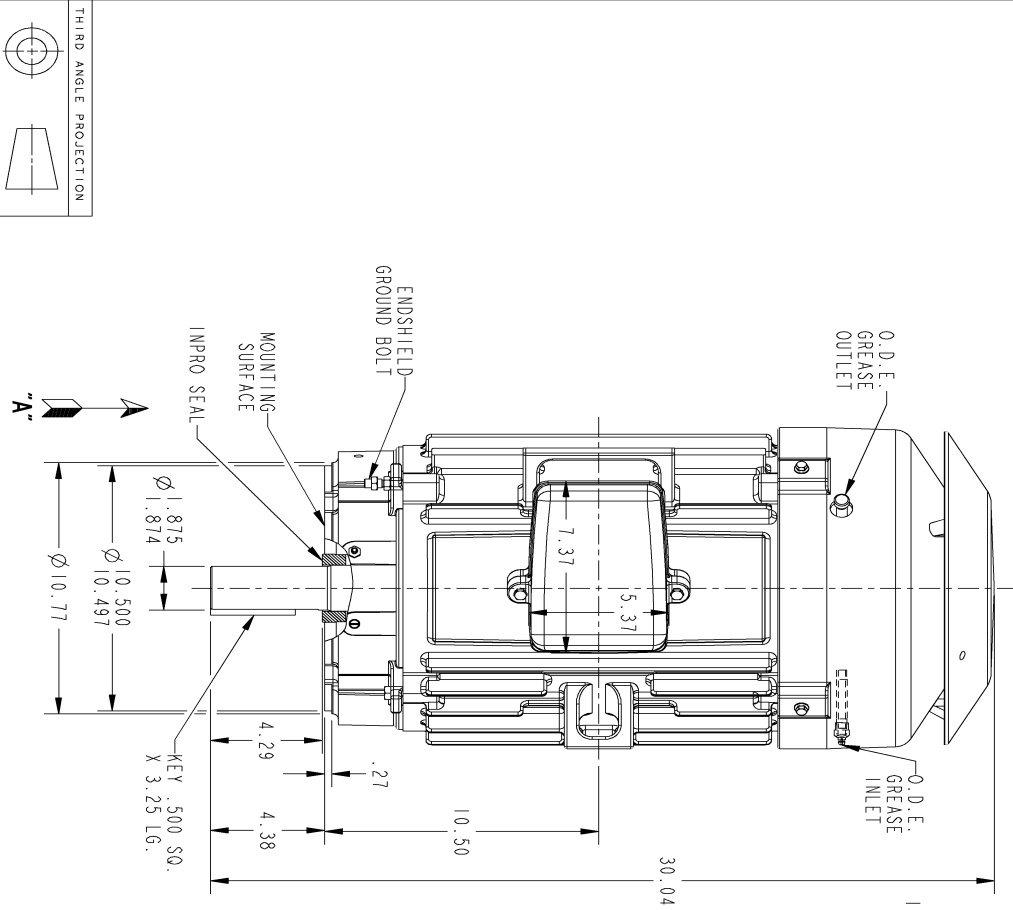

VIEW AT "A"

SIGNATURES	DATE
AMAND	06/10/10
AMAND	06/10/10
CHIEFO	AMIRAYANA
ENGRS	
WGS	
QUALITY	
ISSUED	AMIRAYANA
SOLD MODEL	4002B5828PDP5310

TITLE	SCALE
INDUCTION MOTOR OUTLINE IEEE-841 SPEC AND DRIP COVER (1050° RABBIT) FME: KS284TCV TEC 'C' FACE FOOTLESS	0.220

SIZE DRAWING	REV
4002B5828PDP5310	3

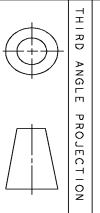

Marks:

Connection Diagram
GEM2034E-FIG7



End shield Assembly		
Part Description	DE Side Part#	ODE Side Part#
End Shield	128D6206PL1	4004D5284SE1
Bearing	235A2608AA01	235A2608AA01
Slinger/Inproseal	235A4575GC7	4002B5914AG5

Fan & Fan Cover Assembly	
Part Description	Part#
Fan	159C6700G02
Fan Cover	4003C5528BN-G01

Conduit & Accessories Box Assembly	
Part Description	Part#
Conduit Box	4002B5728PA-G01

Mechanical Accessories	
Part Description	Part#
Brake	
Tachometer	