

TYPE	OUTPUT		POLE	TIME RATING	VOLTAGE V	Hz	SYN.SPEED R.P.M
	HP.	KW.					
AEHH8NCF	300	223.8	2	CONT.	460	60	3600

TOTALLY ENCLOSED FAN-COOLED TYPE. SQUIRREL-CAGE ROTOR

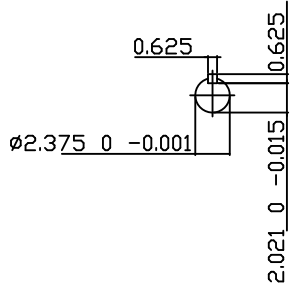
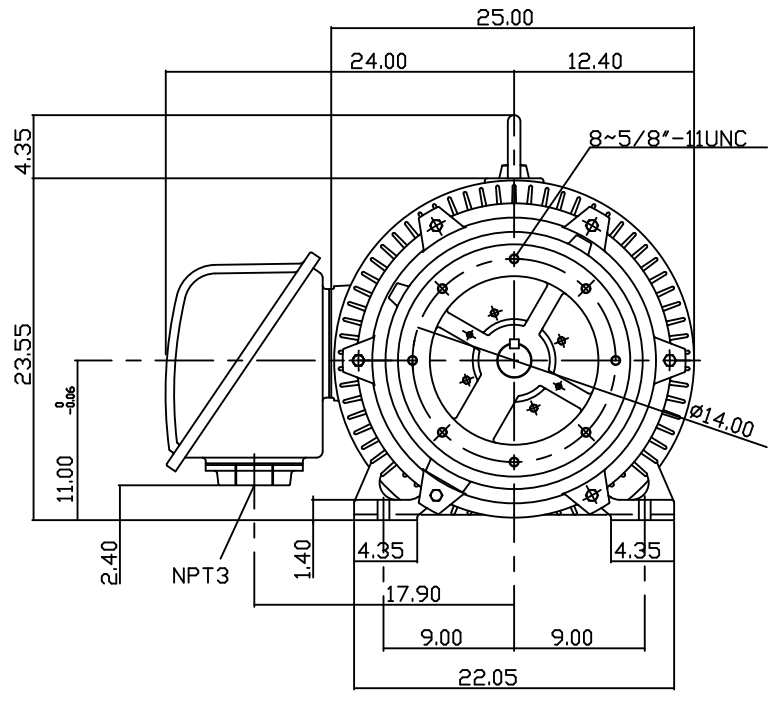
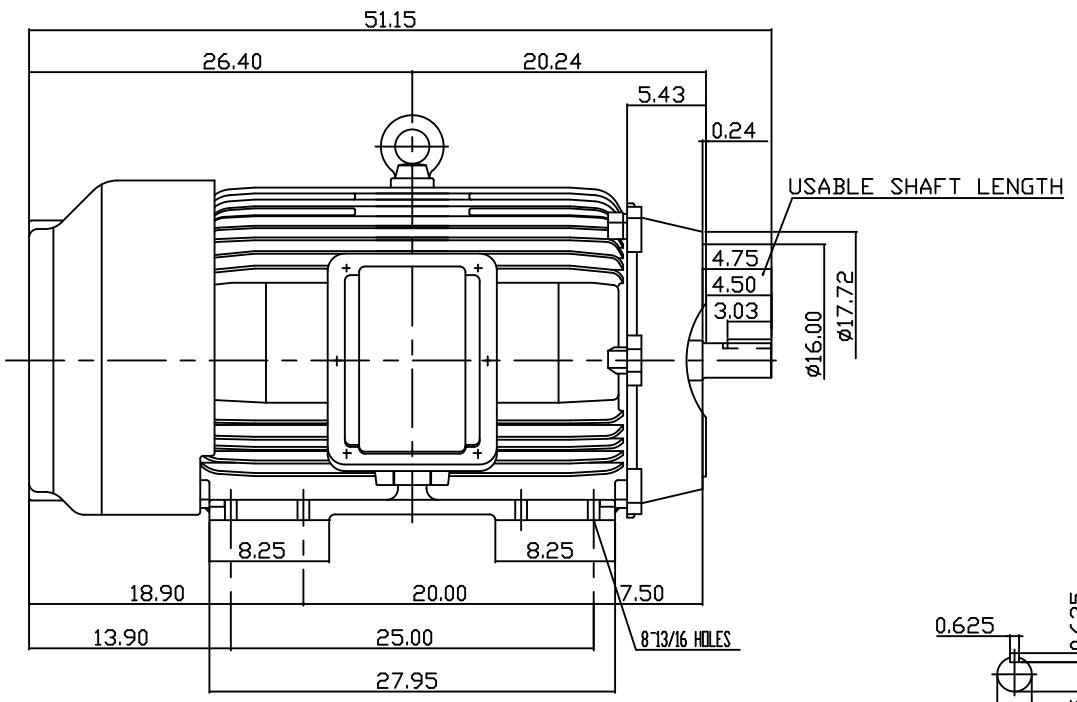

- NOTE:
1. DIMENSIONS IN INCH
 2. FRAME NO. 449TSC
 3. F CLASS INSULATION, S.F.1.15
 4. FOR DIRECT FLEXIBLE COUPLING
 5. ENCLOSURE: IP54
 6. BEARING SIZE: DRIVE END: 6314C3
NON-DRIVE END: 6314C3
 7. APPROX. WEIGHT: 3100 LBS

TW-56C

DWN.	Y.ZHU	JAN 07 2006
CHKD.	H.HUANG	JAN 07 2006
APPD.	C.WANG	JAN 07 2006

DATE	JAN. 11, 2013	OUTLINE DIMENSIONS
CAT. #:	EP3002C	3-PHASE INDUCTION MOTOR
TEC Westinghouse		DWG. NO. REV: 00
		3B040C725