

EIXO/SHAFT	
PADRÃO/STANDARD	X
OPCIONAL/OPTIONAL	
ESPECIAL/SPECIAL	

Dimensões em polegada  
Dimensions in inches

THIS IS AN UPDATED REVISION, THE PREVIOUS ONE MUST BE DISREGARDED.

A

B

C

D

E

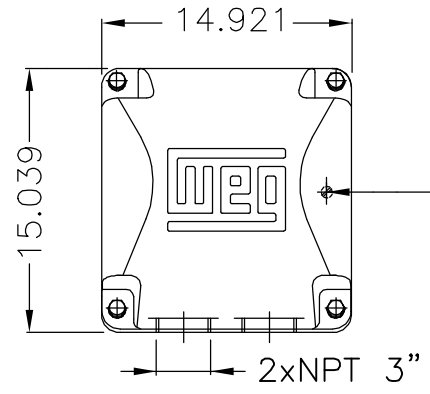
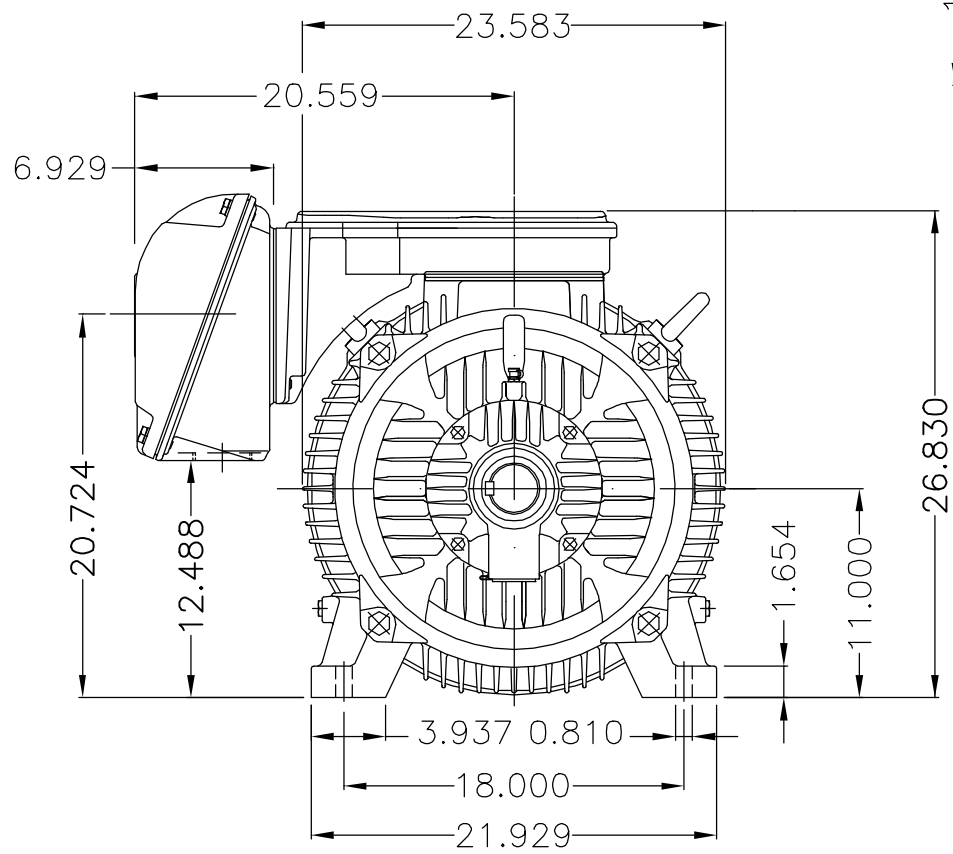

Main terminal box

Grounding for leads 35-70 mm<sup>2</sup> / 1-2/0 AWG

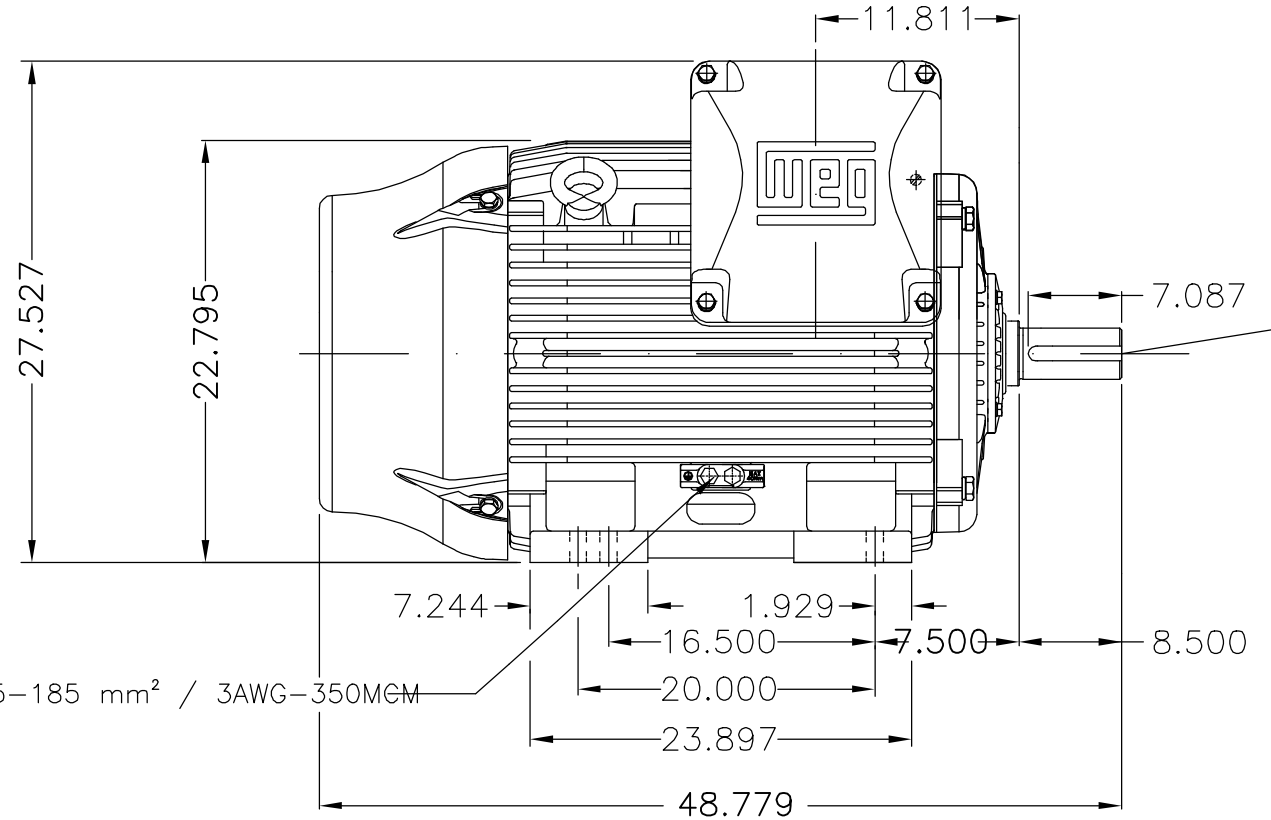

Grounding for leads 25-185 mm<sup>2</sup> / 3AWG-350MCM

Center Hole  
DUNC 3/4"-10 WEG TBG12

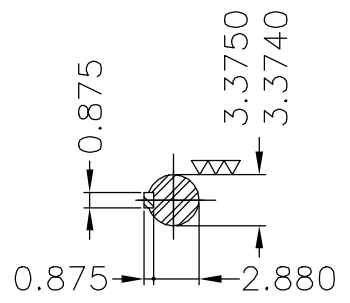

DE Shaft End

Linha do motor: Crusher Duty / Motor purpose: Crusher Duty	
Rolamento dianteiro de rolos / DE roller bearing	
Dispositivo de travamento de eixo / Shaft locking device	
Cor RAL 5009 / Color RAL 5009	
Plano de pintura 203A / Painting plan 203A	
Forma construtiva B3D / Mounting B3R(D)	
<b>WEG EQUIPAMENTOS ELETRICOS S/A</b>	

500001311302	ALT. CONF. CLAIM 414668751	GABRIELID	JMANENTE	23.05.2017	01			
500001307387	DOCUMENTO NOVO	GABRIELID	JMANENTE	09.05.2017	00			
ECM	LOC	SUMMARY OF MODIFICATIONS		EXECUTED	CHECKED	RELEASED	DATE	VER
EXECUTED	GABRIELID		THREE PHASE W22 MOTOR		<b>10004923855</b> 000   01			
CHECKED			FRAME 445/7T IP55 TEFC					
RELEASED	JMANENTE							
REL DT	09.05.2017	WMO	Jaragua do Sul	Product Engineering	SHEET	1 / 1		

200 HP	06 Poles	60Hz	414668751	D
150 HP	06 Poles	60Hz	414668751	C
250 HP	04 Poles	60Hz	414658029	B
200 HP	04 Poles	60Hz	414668751	A