

Dimensional Drawing

Catalogue	Model	HP	Pole	kW	Rating	Voltage	Hz	RPM
SDP0252	ASHH	25	2	19	Continuous	230 / 460 V	60	3600

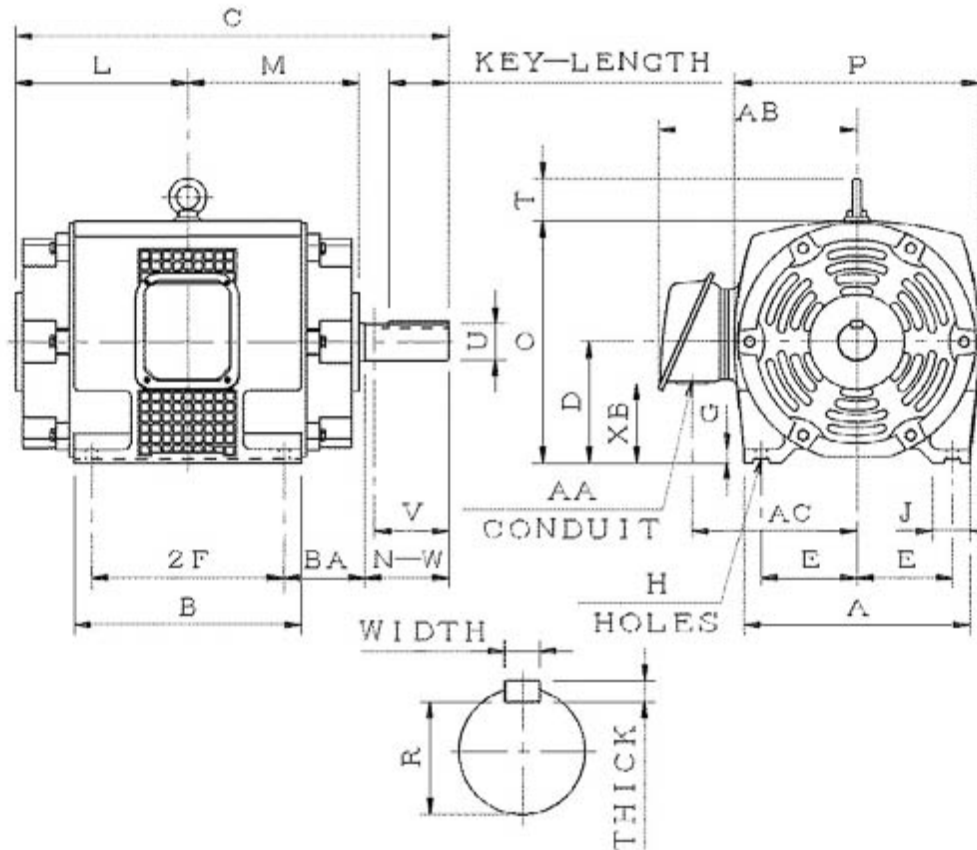

ASHH-SMP-3

Frame Size	Mounting					A	B	C	CD	D	
	E	2F	2F2	H	BA						
256T	5	10		0.53	4.25	11.8	11.8	22.19		6.25	
G	J	K	L	M	O	P	T	Key			Keyseat
0.65	1.95		8.95	8.95	12.7	12.7	2	Width	Thick	Length	R
								0.375	0.375	2.91	1.416
Terminal Housing				Aux Box		C/D Flange					
AA	AB	AC	XB	AE	AX	BB	AH	AK	BD	Aj	BF
1.38	10.28	8.58	4.2								
Shaft Extension			Bearings		Approx. Weight Lbs	SPL dBA/3ft	Ins. Class	S.F.	Drive Method	Dimensions	
N-W	U	V	DE	NDE							
4	1.625	3.9	6310ZZ	6309ZZ	287	75	F	1.15	Direct Coupling / Belt Drive	Inches	

Technical Data Sheet

Motor Type: ASHH

Catalogue No: SDP0252

Nameplate Information

HP	Pole	RPM	Frame	Voltage	Hz	Phase
25	2	3530	256T	230 / 460	60	3
Enclosure	Ins. Class	Service Factor	Time Rating	NEMA Design	Rated Amb.	Rated Altitude
ODP	F	1.15	Continuous	C	-40 to 40 °C	<3300 ft

Typical Performance

Efficiency (%)				Power Factor (%)		
Full Load		3/4 Load	1/2 Load	Full Load	3/4 Load	1/2 Load
Nom.	Min.					
91.7	90.2	92.4	92.4	92.0	91.0	87.0
Torque				Current (A)		
Full Load (lb-ft)	Locked Rotor (% FLT)	Pull Up (% FLT)	Break Down (% FLT)	No Load	Full Load	Locked Rotor
37.18	220	160	260	10.8 / 5.4	55.5 / 27.8	365 / 183
NEMA KVA Code	Inertia (WR ²)			Safe Stall Time (s)		Noise Level Sound Press. dB(A)
	Rotor (lb-ft ²)	NEMA Load (lb-ft ²)	Max. Allowable (lb-ft ²)	Cold	Hot	
G	1.224	26	38	17	12	75

VFD Duty Information

Speed Range			VFD		S.F.
Constant Torque	Variable Torque	Constant Power	Carrier	Type	
6-60Hz	3-60Hz	60-120Hz	≤ 5 kHz	VPWM or CPWM	1.0 Only

Additional Information

Bearings		Approx. Weight
DE	NDE	lbs
6310ZZ	6309ZZ	287

Hazardous Locations Information

N/A	
Temp Code (Sinewave / VFD)	/