

TYPE	OUTPUT		POLE	TIME RATING	VOLTAGE	Hz	SYNSPEED
	HP.	KW.					
AEHGTK	700	522	8	CDNT.	2300/4160	60	R.P.M. 900

TOTALLY ENCLOSED FAN-COOLED TYPE, SQUIRREL-CAGE ROTOR

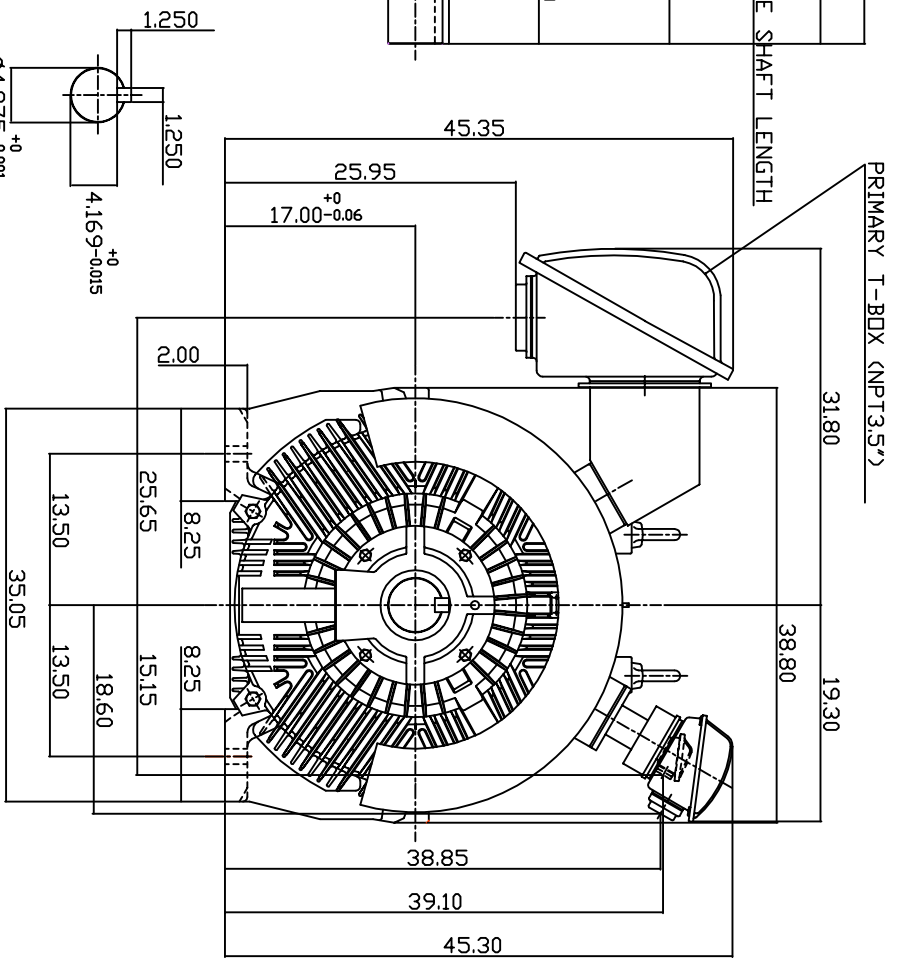
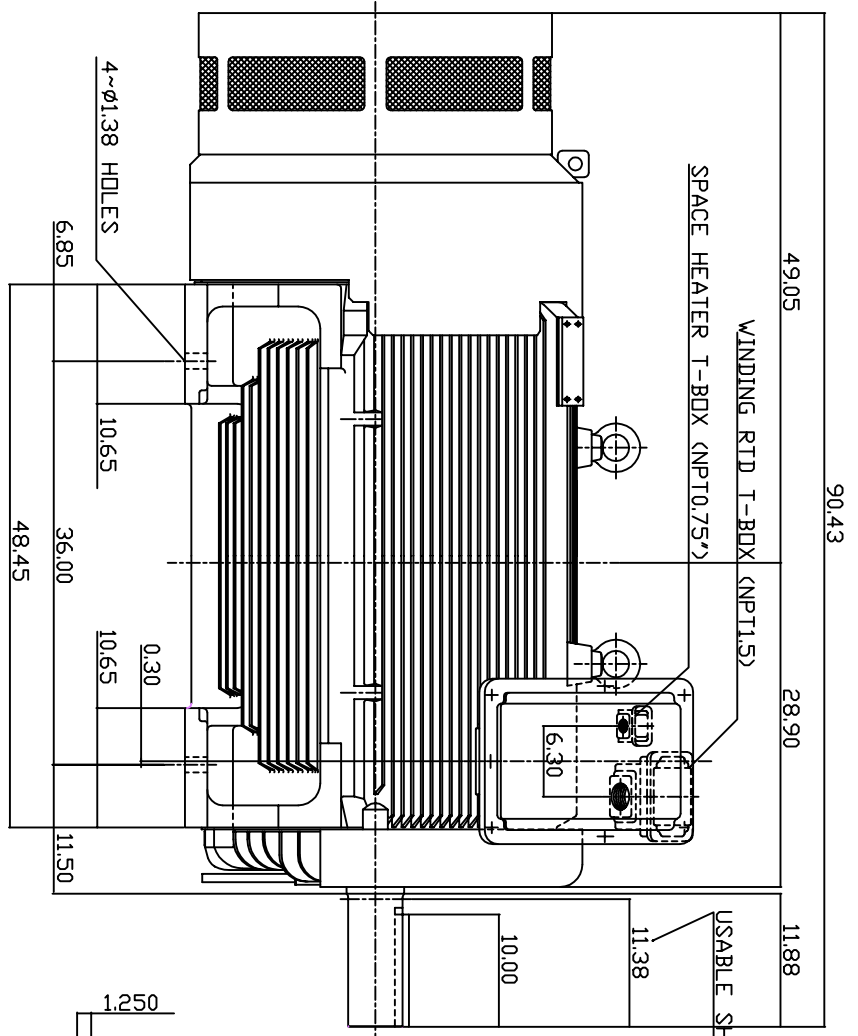

- NOTE: 1. DIMENSIONS IN INCH.
 2. FRAME NO. 6808C
 3. F CLASS INSULATION, S.F.1.15
 4. FOR BELT DRIVE APPLICATIONS
 5. WITH SPACE HEATER 120 VOLT SINGLE PHASE 300 WATTS
 6. 100 OHM PLATINUM WINDING RTD'S 2/PHASE
 7. BEARING SIZE: DRIVE END: NU326
 NDN-DRIVE END: 6322
 8. MOTOR APPROX. WEIGHT: 8650 LBS

D.W.N.	W.L.LIN	APR-17-2003
CHKD.	W.L.LIN	APR-17-2003
APPD.	C.WANG	APR-17-2003

DATE	MAY 6, 2004	OUTLINE DIMENSIONS
CATALOG NO.	KG7008R	3-PHASE INDUCTION MOTOR
DWG NO.	3A040T4623	REV: 00

TW-66C