

Product Information Packet

November 8, 2016

Data shown is for the current revision model #. Ensure your nameplate model # matches.

Model Number:	5KS256XAA204D3
Catalog Number:	M9572
Instruction Manual:	GEI-56128
Connection Diagram:	GEM2034E-FIG1
Outline Drawing:	4002B5825PAP5311

Accessory Connection Diagrams			
Bearing Thermocouple:	None	Heater:	None
RTD:	None	Thermistor:	None
Thermostat:	None	Winding Thermocouple:	None
Bearing RTD:	None		

Table of Contents

Specification	01
Performance Characteristics	02
Outline Drawing	03
Connection Drawing(s)	04
Spare parts	05



Marks:

MODEL NUMBER:	5KS256XAA204D3	Estimated Weight:	350 Lbs
Outline Drawing:	4002B5825PAP5311	Time Rating:	CONT
Connection Diagram:	GEM2034E-FIG1	Enclosure:	TEFC
Instruction Book:	GEI-56128	Encl Construction:	841
Design Code:	25BD1231B	Ambient Max(°C):	40
Type:	KS	Alt Ambient Max(°C):	--
Frame:	256T	Insulation Class:	H
Phases:	3	NEMA Design:	B
Poles:	4	Nominal Efficiency:	93 %
Output Power:	20HP 14.8KW	Guaranteed Efficiency:	92.4
RPM:	1775	3/4 Load Efficiency:	93.8
Voltage:	575	KVA Code:	G
Hertz:	60	Max KVAR:	6.6
Amps - FL:	19.2	Power Factor:	84.0
Service Factor:	1.15	Bearing - DE:	6309ZC3
Alt Service Factor:	--	Bearing - ODE:	6309ZC3

Enclosure is Totally Enclosed Fan-Cooled

Stamped Nameplate Notes:

IEEE-STD-841-2009
 DE BRG 45BC03JP30 ODE BRG 45BC03JP30
 STAMP NP249A5564P051 AS BELOW:
 MODEL:5KS256XAA204D3 S/N: XXX
 CSA CERTIFIED CSA09.2216219 FOR EX NA IIC 200 C GC
 CL1ZONE2 AEXNAIIC 200 C; CL1DIV2 GRP ABCD 200 C
 IN -25C <= AMB <= 40C, 1.0 SF ON SINE-WAVE PWR
 SURF TEMP 200 C AT 1.15 SF ON SINE-WAVE PWR
 OR 200 C VT OR 200 C CT OR 200 C CHP PWM CONTROL
 ALTERNATE RATING FOR PWM CONTROL 1.0 SF 40 C AMB
 VT 0-60 HZ, CT 6-60 HZ, CHP 60-90 HZ.

Additional Information:

4P - T EXTN
 STANDARD FLOOR MOUNT
 C/BOX 137 CU IN-1.25 NPT
 F1 CONDUIT BOX MOUNTING
 PAINTED FRAME ID & SHAFT,
 FAN COVER INSIDE & ODE E/S OUTSIDE
 ROUTINE AND 5 POINT VIBRATION TESTS INCL IN C/BOX
 INPRO SEAL BOTH ENDS
 GROUND SCREW ON FRAME
 SHAFT RUNOUT LIMIT .001" TIR
 COPPER WASHER UNDER HEADS OF BEARING CAP BOLTS
 APPLY TITE-SEAL (A50CD427A) ON BEARING CAP SCREWS, RABBETS,
 AND PLUG THREADS
 OIL RESISTANT SLEEVING ON LEADS



Performance Characteristics

1st Winding 1st Connection

Design: 25BD1231B

Marks:

LOAD %	125.0	115.0	100.0	75.0	50.0	25.0	0.0
% EFF	92.45	92.83	93.51	93.8	93.55	90.75	0.00
% PF	85.69	85.19	83.92	79.62	69.85	47.46	4.29
AMPS	23.63	21.78	19.08	15.04	11.46	8.69	7.41

TORQ(FL)#FT	59.15	TORQ(LR)%FL	216.27	TORQ(BD)%FL	270.37
AMPS(LR)	114.41	PF AT START	0.45		

This motor is capable of two cold or one hot start with a maximum connected load inertia of 673 Lb-Ft Sq (28.33 Kg-meter Sq) at 100% voltage, where the load torque varies with the square of the speed. Acceleration time with maximum inertia and the above load type is 41 seconds. Safe stall time at 100% voltage is 93 seconds cold, 59 seconds hot. Rotor inertia is 3.04 Lb-Ft Sq (0.13 Kg-meter Sq).

Open Circuit A-C:	0.478	Short Circuit D-C:	0.014
Short Circuit A-C:	0.024	X/R Ratio:	5.139
Stator Slots:	48	Rotor Slots:	40

Speed Torque Current Curve (First Connection, First Speed)

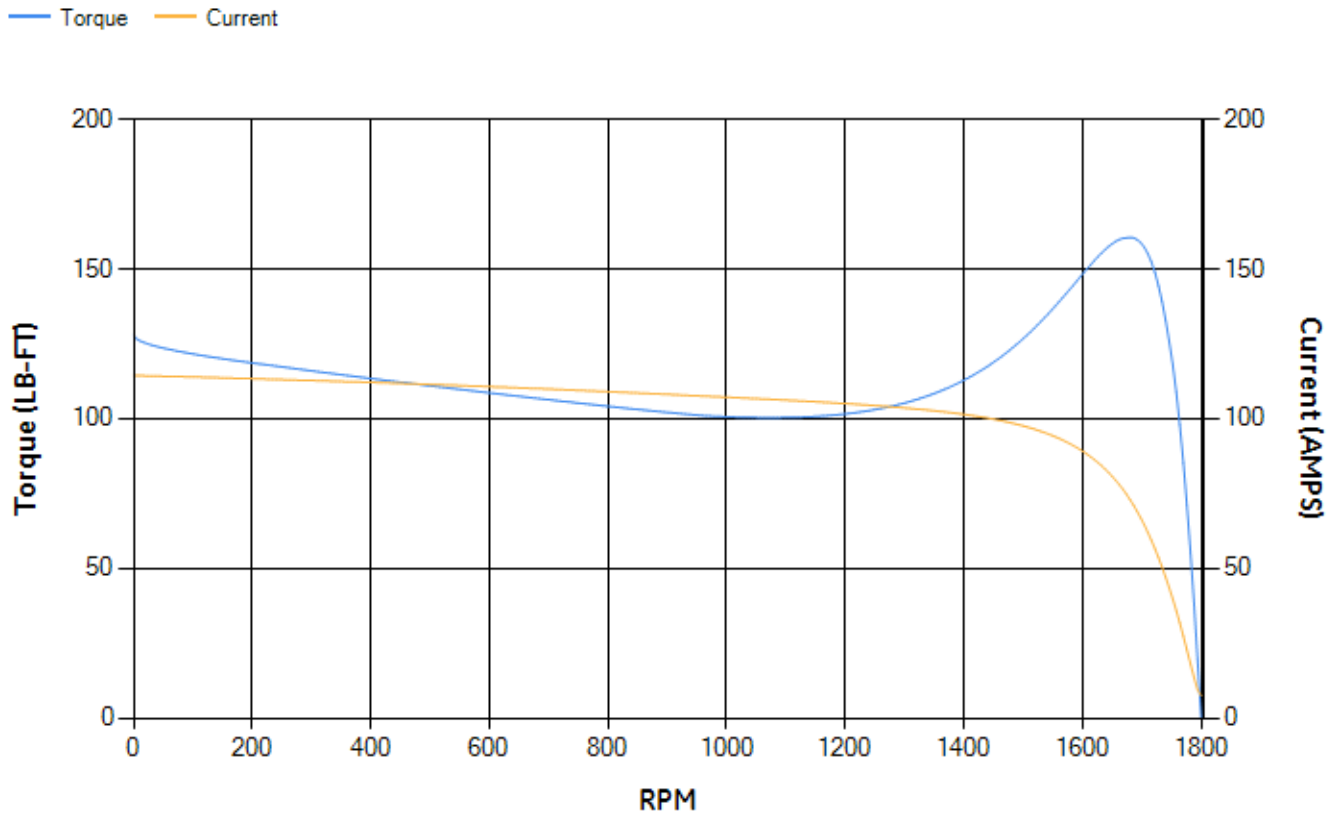

Marks:

NOTE 1: CONDUIT BOX MAY BE ASSEMBLED WITH ENTRANCE UP, DOWN OR TO EITHER SIDE.
 NOTE 2: F1 ASSEMBLY AS SHOWN. F2 ASSEMBLY CONDUIT BOX ON OPPOSITE SIDE FROM SHOWN LOCATION.
 NOTE 3: SHAFT RUNOUT WILL NOT EXCEED .001" I. P.R.

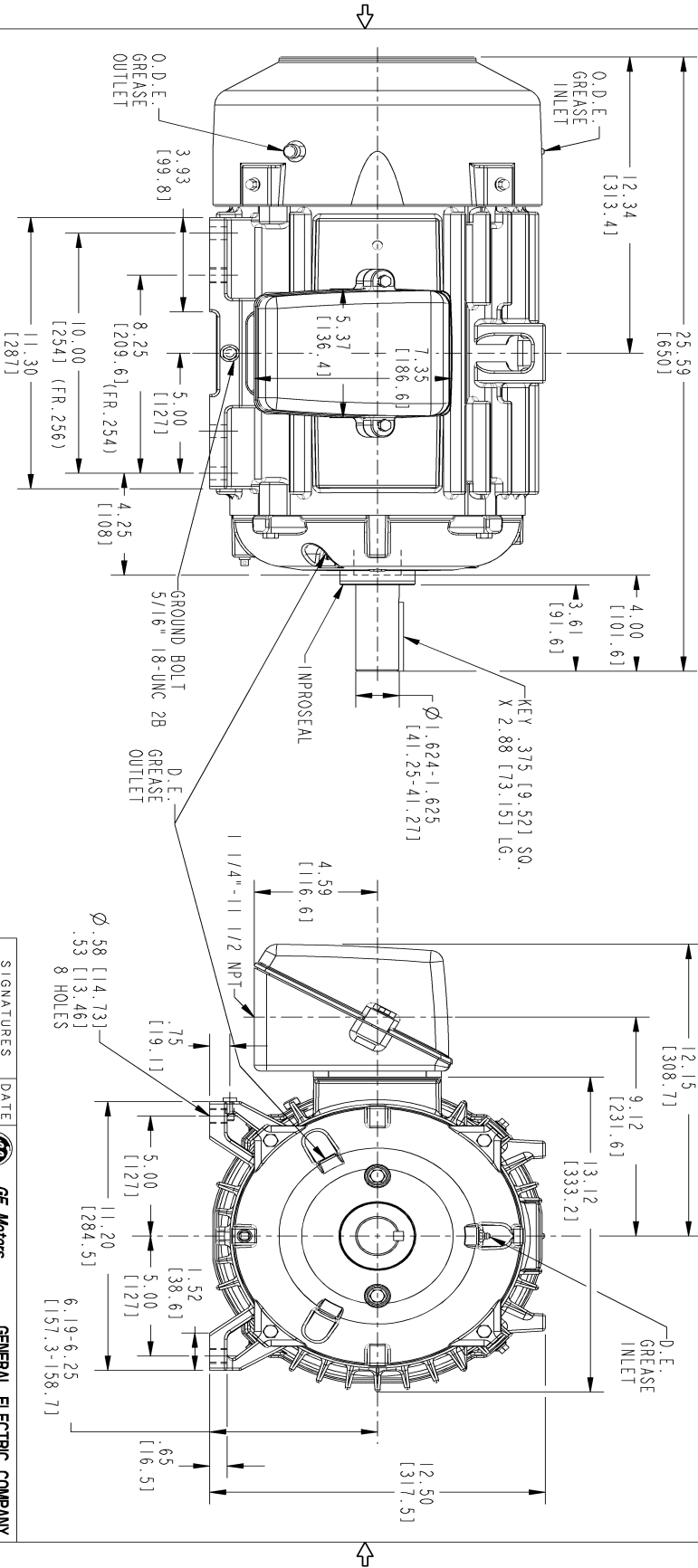

REV.	DESCRIPTION	DATE	APPROVED

SIZE	DRAWING NO.	REV	SHEET
B	4002B5825PAP5311	0	1

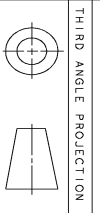

THIRD ANGLE PROJECTION

SIGNATURES		DATE	
MODEL	TEJASNI	05/18/15	
DETAIL	TEJASNI	05/18/15	
CHECKED	KARTHICK	05/18/15	
ENGR	SHAMANTHI	05/18/15	
QC			
ISSUED	TEJASNI	05/18/15	
SOLID MODEL	4002B5825PAP5311		

GE Motors
GENERAL ELECTRIC COMPANY

TITLE
INDUCTION MOTOR OUTLINE
 STANDARD CONSTRUCTION FOR IEEE-841 SPEC.
 FMR: FR250T TFC XSD ULTRA

SIZE DRAWING
4002B5825PAP5311

SCALE: 0.250 REF. No.: 4002B5825PAP5311 SHEET 1 OF 1

Marks:

Connection Diagram
GEM2034E-FIG1

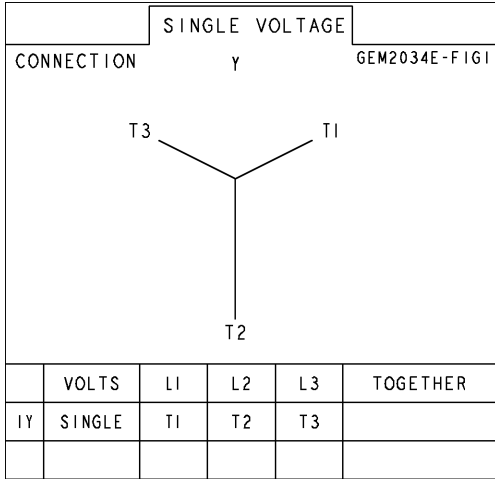

End shield Assembly		
Part Description	DE Side Part#	ODE Side Part#
End Shield	4004D5283PB1	4004D5283SE1
Bearing	235A2607AA01	235A2607AA01
Slinger/Inproseal	4002B5914AF4	4002B5914AG4

Fan & Fan Cover Assembly	
Part Description	Part#
Fan	159C6700G02
Fan Cover	4003C5788PA1

Conduit & Accessories Box Assembly	
Part Description	Part#
Conduit Box	4002B5728PA-G04

Mechanical Accessories	
Part Description	Part#
Brake	
Tachometer	