

Product Information Packet

November 9, 2016

Data shown is for the current revision model #. Ensure your nameplate model # matches.

Model Number:	5KS284XAA100D3
Catalog Number:	M8923
Instruction Manual:	GEI-56128
Connection Diagram:	GEM2034E-FIG1
Outline Drawing:	4002B5828PBP5311

Accessory Connection Diagrams			
Bearing Thermocouple:	None	Heater:	None
RTD:	None	Thermistor:	None
Thermostat:	None	Winding Thermocouple:	None
Bearing RTD:	None		

Table of Contents

Specification	01
Performance Characteristics	02
Outline Drawing	03
Connection Drawing(s)	04
Spare parts	05



Marks:

MODEL NUMBER:	5KS284XAA100D3	Estimated Weight:	460 Lbs
Outline Drawing:	4002B5828PBP5311	Time Rating:	CONT
Connection Diagram:	GEM2034E-FIG1	Enclosure:	TEFC
Instruction Book:	GEI-56128	Encl Construction:	841
Design Code:	28BD0164A	Ambient Max(°C):	40
Type:	KS	Alt Ambient Max(°C):	--
Frame:	284TC	Insulation Class:	H
Phases:	3	NEMA Design:	B
Poles:	2	Nominal Efficiency:	91.7 %
Output Power:	25HP 18.5KW	Guaranteed Efficiency:	91.0
RPM:	3550	3/4 Load Efficiency:	92.6
Voltage:	460	KVA Code:	G
Hertz:	60	Max KVAR:	4.8
Amps - FL:	28.0	Power Factor:	91.0
Service Factor:	1.15	Bearing - DE:	6310ZC3
Alt Service Factor:	--	Bearing - ODE:	6310ZC3

Enclosure is Totally Enclosed Fan-Cooled

Stamped Nameplate Notes:

IEEE-STD-841-2009
 DE BRG 50BC03JP30 ODE BRG 50BC03JP30
 STAMP NP249A5564P051 AS BELOW:
 MODEL:5KS284XAA100D3 S/N: XXX
 CSA CERTIFIED CSA09.2216219 FOR EX NA IIC 200 C GC
 CL1ZONE2 AEXNAIIC 200 C; CL1DIV2 GRP ABCD 200 C
 IN -25C <= AMB <= 40C, 1.0 SF ON SINE-WAVE PWR
 SURF TEMP 260 C AT 1.15 SF ON SINE-WAVE PWR
 OR 215 C VT OR 215 C CT OR 230 C CHP PWM CONTROL
 ALTERNATE RATING FOR PWM CONTROL 1.0 SF 40 C AMB
 VT 0-60 HZ, CT 8.6-60 HZ, CHP 60-90 HZ.

Additional Information:

2P - T EXTN
 STANDARD FLOOR MOUNT
 C/BOX 137 CU IN-1.50 NPT
 F1 CONDUIT BOX MOUNTING
 "C" FACE AT DE ENDSHIELD
 PAINTED FRAME ID & SHAFT,
 FAN COVER INSIDE & ODE E/S OUTSIDE
 ROUTINE AND 5 POINT VIBRATION TESTS INCL IN C/BOX
 INPRO SEAL BOTH ENDS
 GROUND SCREW ON FRAME
 ROTATE D.E. E/SHIELD 90 DEG. PER OUTLINE
 SHAFT RUNOUT LIMIT .0015" TIR
 COPPER WASHER UNDER HEADS OF BEARING CAP BOLTS
 APPLY TITE-SEAL (A50CD427A) ON BEARING CAP SCREWS, RABBETS,

AND PLUG THREADS
OIL RESISTANT SLEEVING ON LEADS

Performance Characteristics

1st Winding 1st Connection

Design: 28BD0164A

Marks:

LOAD %	125.0	115.0	100.0	75.0	50.0	25.0	0.0
% EFF	90.74	91.26	92.12	92.64	92.5	89.49	0.00
% PF	90.88	91.02	90.93	89.56	84.83	68.28	8.7
AMPS	35.47	32.39	27.93	21.15	14.91	9.57	6.63

TORQ(FL)#FT	36.99	TORQ(LR)%FL	227.95	TORQ(BD)%FL	270.04
AMPS(LR)	174.18	PF AT START	0.38		

This motor is capable of two cold or one hot start with a maximum connected load inertia of 81 Lb-Ft Sq (3.41 Kg-meter Sq)at 100% voltage, where the load torque varies with the square of the speed. Acceleration time with maximum inertia and the above load type is 19 seconds. Safe stall time at 100% voltage is 39 seconds cold, 22 seconds hot. Rotor inertia is 2.13 Lb-Ft Sq (0.09 Kg-meter Sq).

Open Circuit A-C:	0.802	Short Circuit D-C:	0.013
Short Circuit A-C:	0.027	X/R Ratio:	4.951
Stator Slots:	48	Rotor Slots:	38

Speed Torque Current Curve (First Connection, First Speed)

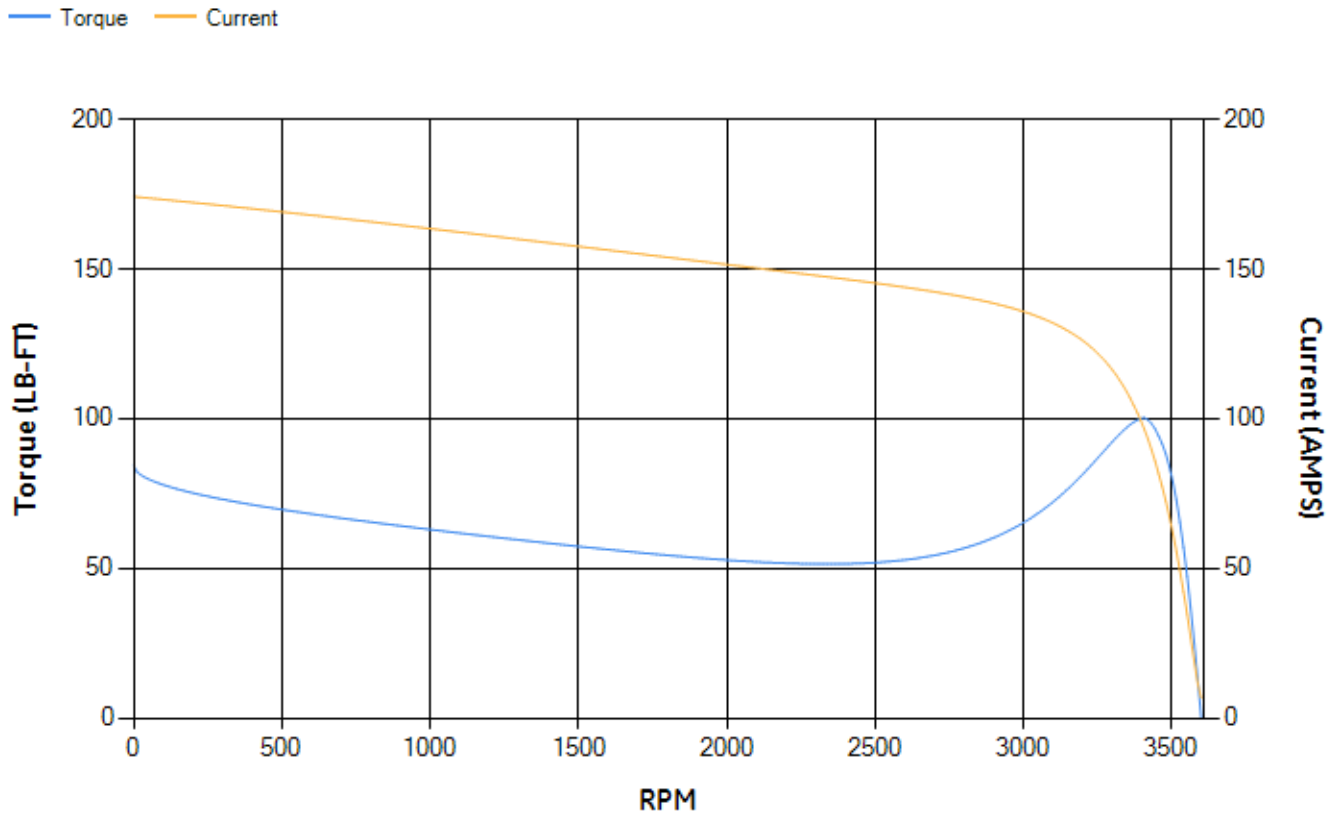

Marks:

- NOTE 1: CONDUIT BOX MAY BE ASSEMBLED WITH ENTRANCE UP, DOWN OR TO EITHER SIDE.
- NOTE 2: F1 ASSEMBLY AS SHOWN. F2 ASSEMBLY CONDUIT BOX ON OPPOSITE SIDE FROM SHOWN LOCATION.
- NOTE 3: MOUNTING SURFACES WILL BE SQUARE AND CONCENTRIC WITH SHAFT WITHIN .004 T.I.R.
- NOTE 4: SHAFT RUNOUT WILL NOT EXCEED .0015 T.I.R.
- NOTE 5: DE ENDSHIELD ROTATED 90° COUNTER CLOCKWISE.
- NOTE 6: ALL DIMENSIONS ARE IN INCHES, BRACKETED DIMENSIONS ARE IN METRIC (MILLIMETERS)

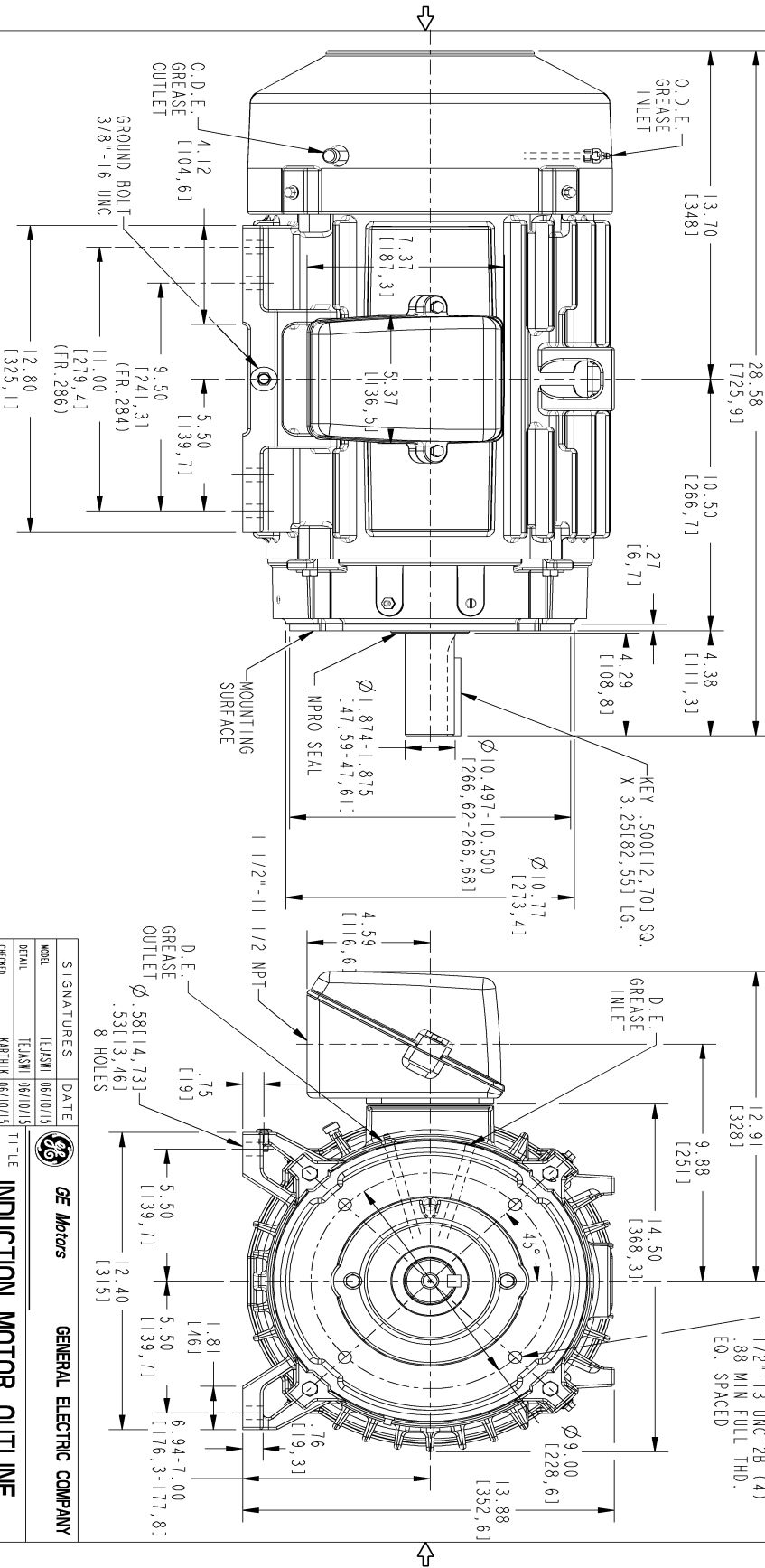

SIZE	DRAWING NO.	REV	SHEET
B	4002B5828PBP5311	0	1

REV.	DESCRIPTION	DATE	APPROVED

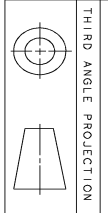

THIRD ANGLE PROJECTION

SIGNATURES		DATE	 GE Motors GENERAL ELECTRIC COMPANY
MODEL	TEJASNI	06/10/15	
DETAIL	TEJASNI	06/10/15	TITLE INDUCTION MOTOR OUTLINE IEEE-841 SPEC, "C" FACE AT DE (1050" RABBIT) FR: 284/286TC
CHECKED	KARHIK	06/10/15	
ENGR	VENKA	06/10/15	
W/			
ISSUED	TEJASNI	06/10/15	SCALE: 0.250 REF. No.: 4002B5828PBP5301
SIZE DRAWING		REV	SHEET
B	0	0	1

Marks:

Connection Diagram
GEM2034E-FIG1

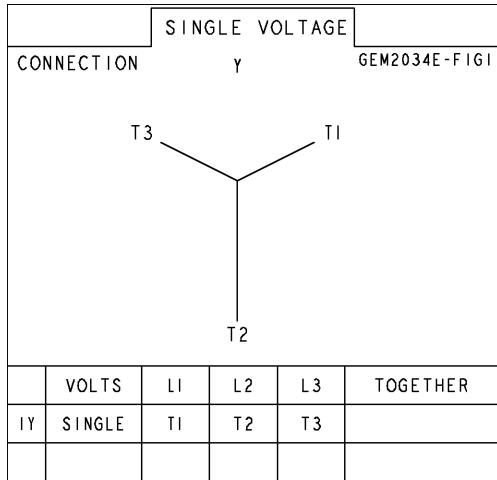

End shield Assembly		
Part Description	DE Side Part#	ODE Side Part#
End Shield	128D6206PL1	4004D5284SE1
Bearing	235A2608AA01	235A2608AA01
Slinger/Inproseal	235A4575GC7	4002B5914AG5

Fan & Fan Cover Assembly	
Part Description	Part#
Fan	159C6704G02
Fan Cover	4003C5789PA1

Conduit & Accessories Box Assembly	
Part Description	Part#
Conduit Box	4002B5728PA-G01

Mechanical Accessories	
Part Description	Part#
Brake	
Tachometer	