

TYPE	OUTPUT		POLE	TIME RATING	VOLTAGE	Hz	SYNSPEED
	HP.	K.W.					
AEHGTK	500	373	8	CDNT.	2300/4160	60	900

TOTALLY ENCLOSED FAN-COOLED TYPE, SQUIRREL-CAGE ROTOR

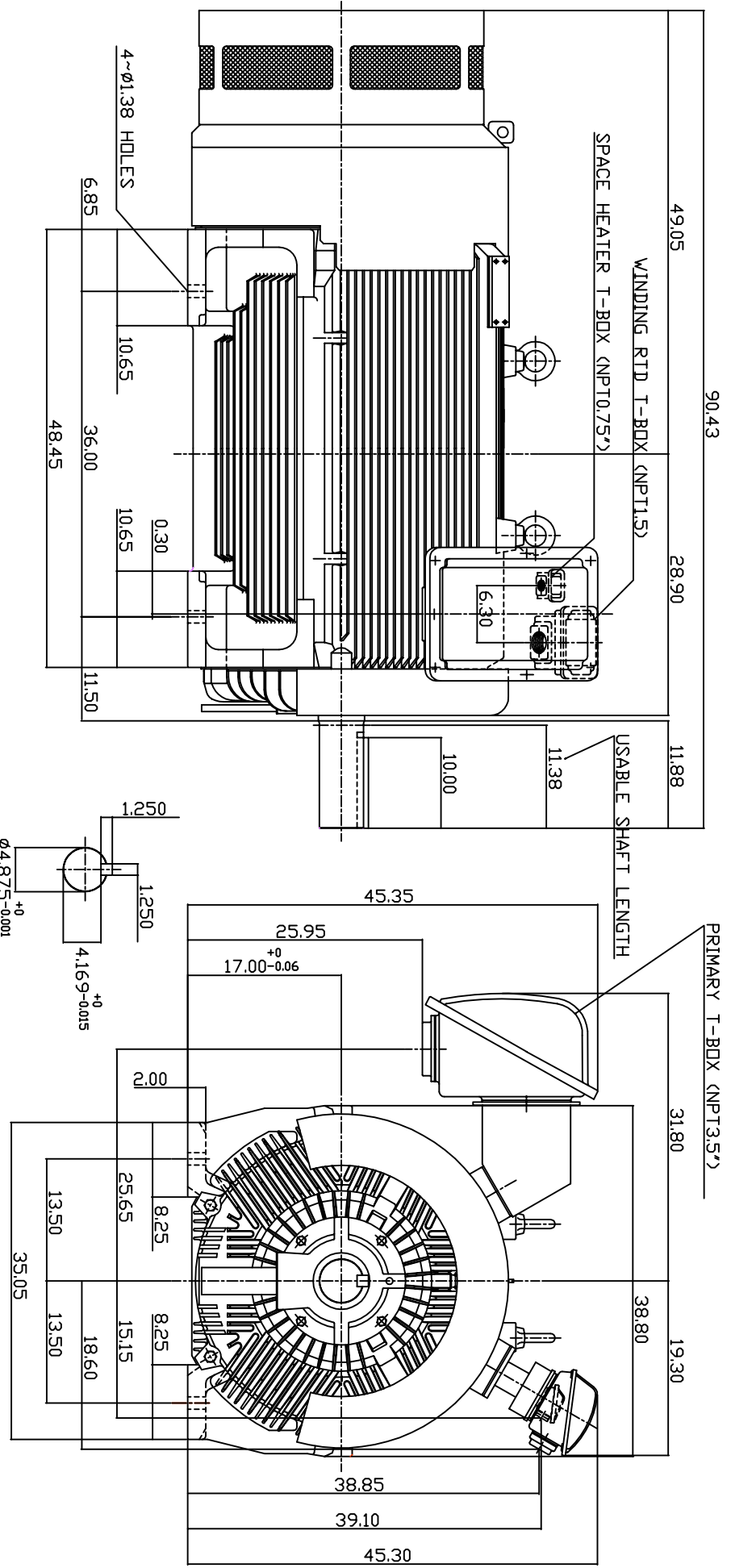

- NOTE: 1. DIMENSIONS IN INCH.
 2. FRAME NO. 6808C
 3. F CLASS INSULATION, S.F. 1.15
 4. FOR BELT DRIVE APPLICATIONS
 5. WITH SPACE HEATER 120 VOLT SINGLE PHASE 300 WATTS
 6. 100 OHM PLATINUM WINDING RTD'S 2/PHASE
 7. BEARING SIZE: DRIVE END: NU326
 NDN-DRIVE END: 6322
 8. MOTOR APPROX. WEIGHT: 7400 LBS

D/W.N.	W.L.LIN	APR-17-2003
CHKD.	W.L.LIN	APR-17-2003
APPD.	C.WANG	APR-17-2003

DATE: MAY 6, 2004
 CATALOG NO: KG5008R
 OUTLINE DIMENSIONS
 3-PHASE INDUCTION MOTOR
 DWG NO. 3A040T4620
 REV: 00

TW-66C