

Product Information Packet

November 8, 2016

Data shown is for the current revision model #. Ensure your nameplate model # matches.

Model Number:	5KS364XAA218C
Catalog Number:	M9391
Instruction Manual:	GEI-56128
Connection Diagram:	GEM2034E-FIG7
Outline Drawing:	239C6200RD

Accessory Connection Diagrams			
Bearing Thermocouple:	None	Heater:	None
RTD:	None	Thermistor:	None
Thermostat:	None	Winding Thermocouple:	None
Bearing RTD:	None		

Table of Contents

Specification	01
Performance Characteristics	02
Outline Drawing	03
Connection Drawing(s)	04
Spare parts	05



Marks:

MODEL NUMBER:	5KS364XAA218C	Estimated Weight:	970 Lbs
Outline Drawing:	239C6200RD	Time Rating:	CONT
Connection Diagram:	GEM2034E-FIG7	Enclosure:	TEFC
Instruction Book:	GEI-56128	Encl Construction:	841
Design Code:	36BD1188A	Ambient Max(°C):	40
Type:	KS	Alt Ambient Max(°C):	--
Frame:	364TS	Insulation Class:	H
Phases:	3	NEMA Design:	B
Poles:	4	Nominal Efficiency:	95.0 %
Output Power:	60HP 44.4KW	Guaranteed Efficiency:	94.5
RPM:	1780	3/4 Load Efficiency:	95.2
Voltage:	460	KVA Code:	G
Hertz:	60	Max KVAR:	20.9
Amps - FL:	71.7	Power Factor:	82.5
Service Factor:	1.15	Bearing - DE:	6314ZC3
Alt Service Factor:	--	Bearing - ODE:	6314ZC3

Enclosure is Totally Enclosed Fan-Cooled

Stamped Nameplate Notes:

IEEE-STD-841-2009
 DE BRG 70BC03JP30, ODE BRG 70BC03JP30
 STAMP NP249A5564P051 AS BELOW:
 MODEL:5KS364XAA218C S/N: XXX
 CSA CERTIFIED CSA09.2216219 FOR EX NA IIC 200 C GC
 CL 1 ZONE2 AEX NA IIC 200C;CL 1 DIV2 GRP ABCD 200C
 IN -25C <= AMB <= 40C, 1.0 SF ON SINE-WAVE PWR
 SURF TEMP 260C AT 1.15SF ON SINE-WAVE PWR
 OR 200 C VT OR 230 C CT OR 200 C CHP PWM CONTROL
 ALTERNATE RATING FOR PWM CONTROL 1.0SF 40C AMB
 VT 0-60 HZ, CT 6-60 HZ, CHP 60-90 HZ.

Additional Information:

4P - TS EXTN
 PAINTED FRAME ID & SHAFT,
 FAN COVER INSIDE & ODE E/S OUTSIDE
 346 CU IN - 3.00" NPT
 INPRO SEAL BOTH ENDS
 OIL RESISTANT SLEEVING ON LEADS
 .0015" TIR SHAFT RUNOUT
 ROUTINE TEST REPORT AND 5 POINT VIBRATION TEST
 REPORT INCLUDED IN C/B
 COPPER WASHER UNDER HEADS OF BEARING CAP BOLTS,
 APPLY TITE-SEAL (A50CD427A) ON BEARING CAP SCREWS,
 RABBETS AND PLUG THREADS.
 GROUND PAD
 F1 MOUNTING

Performance Characteristics

1st Winding 1st Connection

Design: 36BD1188A

Marks:

LOAD %	125.0	115.0	100.0	75.0	50.0	25.0	0.0
% EFF	94.38	94.62	95.12	95.19	94.85	92.38	0.00
% PF	84.34	83.77	82.38	77.77	67.55	44.92	3.18
AMPS	88.19	81.47	71.5	56.89	43.82	33.83	29.16

TORQ(FL)#FT 176.81
AMPS(LR) 412.9

TORQ(LR)%FL 160.18
PF AT START 0.31

TORQ(BD)%FL 260.31

This motor is capable of two cold or one hot start with a maximum connected load inertia of 1190 Lb-Ft Sq (50.1 Kg-meter Sq)at 100% voltage, where the load torque varies with the square of the speed. Acceleration time with maximum inertia and the above load type is 33 seconds. Safe stall time at 100% voltage is 76 seconds cold, 39 seconds hot. Rotor inertia is 12.22 Lb-Ft Sq (0.51 Kg-meter Sq).

Open Circuit A-C: 0.602

Short Circuit D-C: 0.024

Short Circuit A-C: 0.035

X/R Ratio: 9.207

Stator Slots: 60

Rotor Slots: 50

Speed Torque Current Curve (First Connection, First Speed)

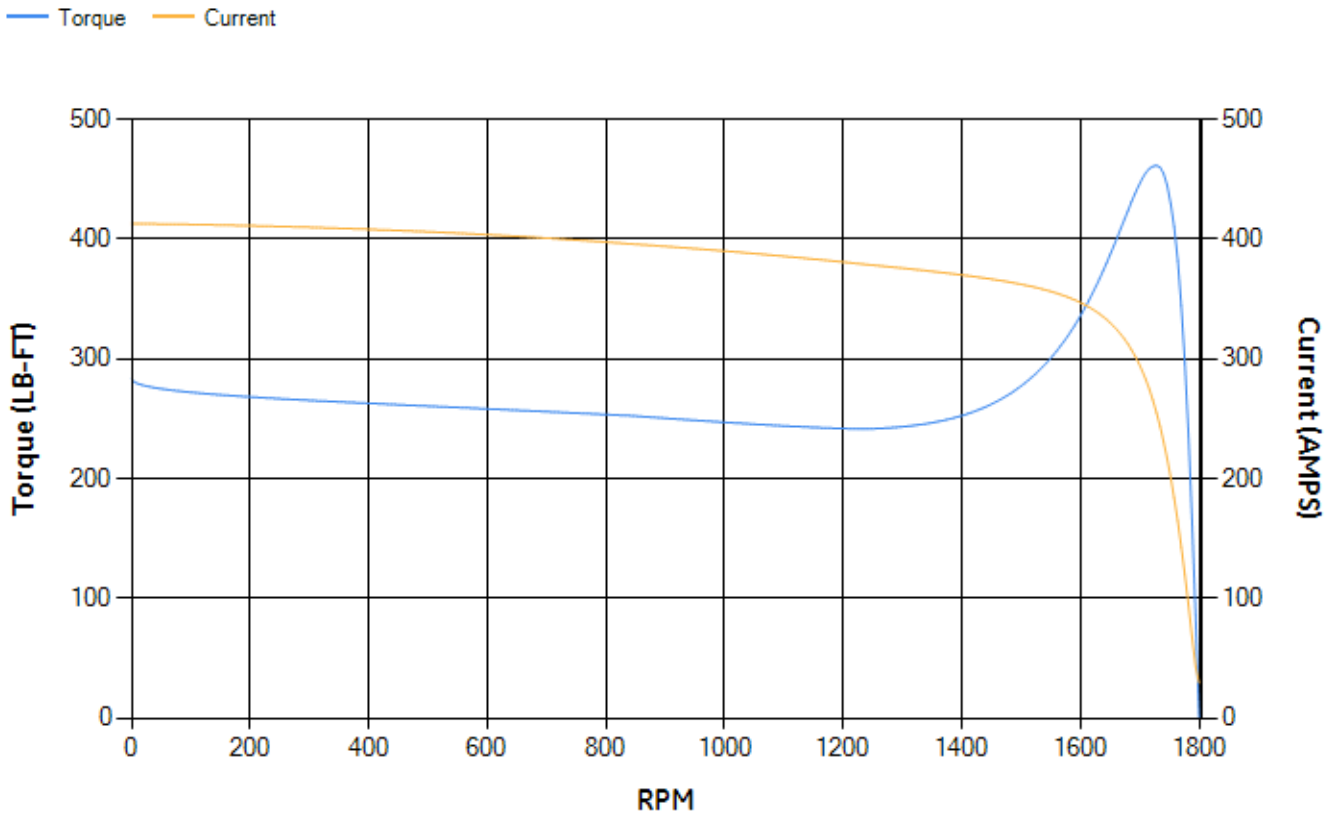

Marks:

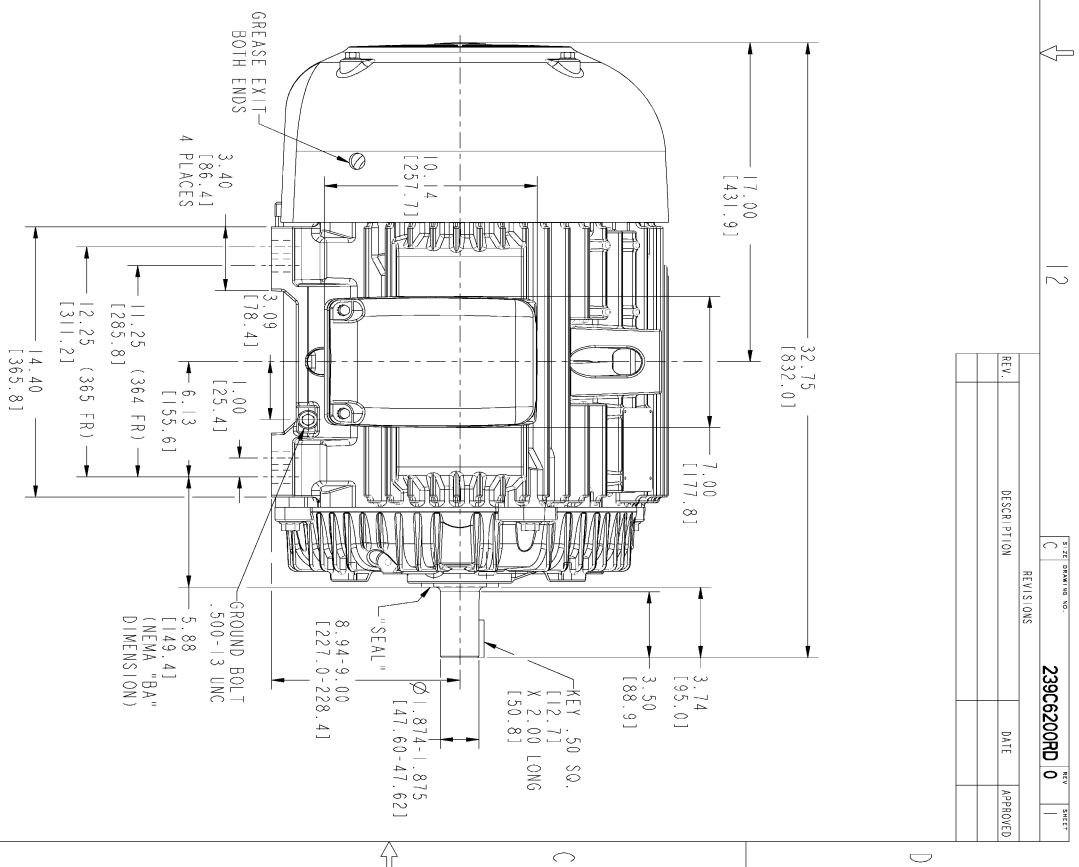
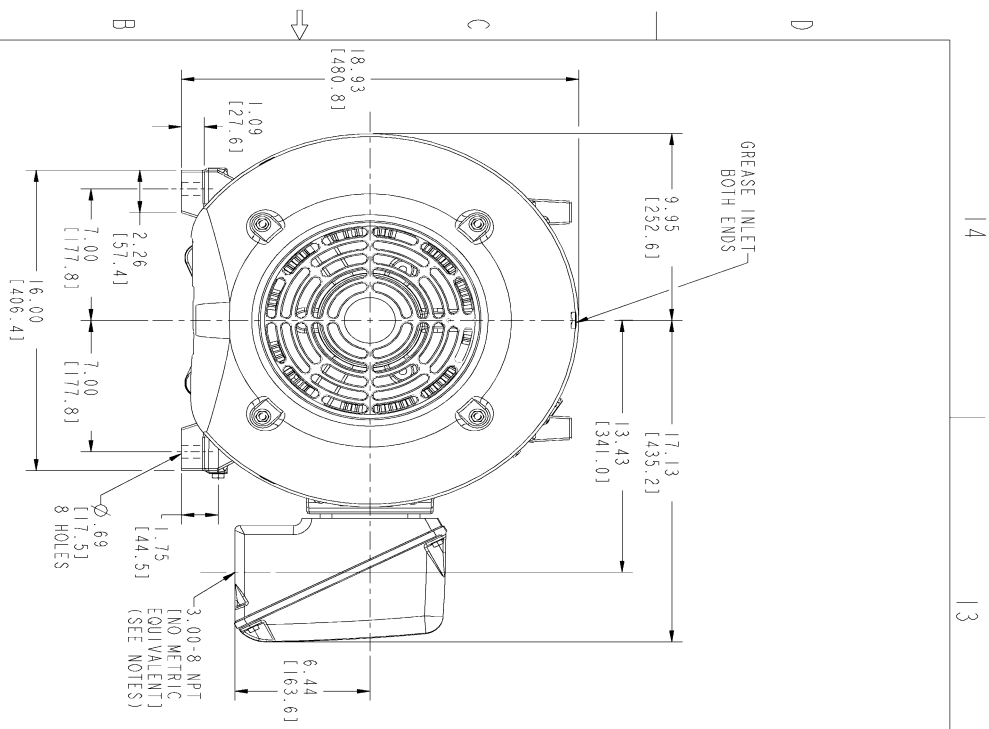

NOTES :

1. CONDUIT BOX MAY BE PLACED WITH THE ENTRANCE DOWN, UP OR ON EITHER SIDE.
2. F-1 ASM AS SHOWN.
3. F-2 ASM HAS CONDUIT BOX ON OPPOSITE SIDE.
4. BRACKETED DIMENSIONS ARE METRIC (MILLIMETERS).
5. TOLERANCE ON PERMISSIBLE SHAFT EXTENSION RUNOUT IS .0015 T.I.R.

REV.	DESCRIPTION	DATE	APPROVED

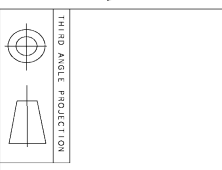

THIRD ANGLE PROJECTION	SCALE: 0.250	REV. No: 239C6200AH	SHEET 1 OF 1
S I G N A T U R E S MODEL: TEJSMI 06/19/15 SERIAL: TEJSMI 06/19/15 CHECKED: VENKAT 06/19/15 DESG: VENKAT 06/19/15 DWG/LIT: TEJSMI 06/19/15 ISSUED: TEJSMI 06/19/15		GE Motors GENERAL ELECTRIC COMPANY TITLE: OUTLINE 364/365 TS TERC XSD 841 346 CU IN. CONDUIT BOX SIZE: DRAWING: 239C6200RD REV: 0	

Marks:

Connection Diagram
GEM2034E-FIG7

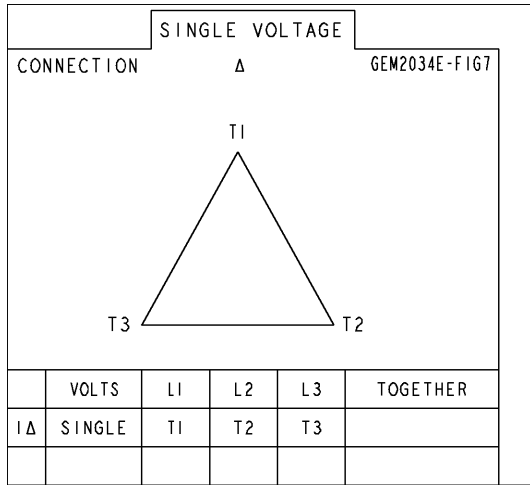

End shield Assembly		
Part Description	DE Side Part#	ODE Side Part#
End Shield	115E4250AA1	115E4250LK1
Bearing	235A2616AA01	235A2616AA01
Slinger/Inproseal	235A4575GS3	235A4575GS3

Fan & Fan Cover Assembly	
Part Description	Part#
Fan	159C7100AA1
Fan Cover	128D6810AA1

Conduit & Accessories Box Assembly	
Part Description	Part#
Conduit Box	149C4429AA2

Mechanical Accessories	
Part Description	Part#
Brake	
Tachometer	