

Product Information Packet

November 8, 2016

Data shown is for the current revision model #. Ensure your nameplate model # matches.

Model Number:	5KS256XAA304D2
Catalog Number:	M9565
Instruction Manual:	GEI-56128
Connection Diagram:	GEM2034E-FIG1
Outline Drawing:	4002B5825PAP5311

Accessory Connection Diagrams			
Bearing Thermocouple:	None	Heater:	None
RTD:	None	Thermistor:	None
Thermostat:	None	Winding Thermocouple:	None
Bearing RTD:	None		

Table of Contents

Specification	01
Performance Characteristics	02
Outline Drawing	03
Connection Drawing(s)	04
Spare parts	05



Marks:

MODEL NUMBER:	5KS256XAA304D2	Estimated Weight:	350 Lbs
Outline Drawing:	4002B5825PAP5311	Time Rating:	CONT
Connection Diagram:	GEM2034E-FIG1	Enclosure:	TEFC
Instruction Book:	GEI-56128	Encl Construction:	841
Design Code:	25BD3060B	Ambient Max(°C):	40
Type:	KS	Alt Ambient Max(°C):	--
Frame:	256T	Insulation Class:	H
Phases:	3	NEMA Design:	B
Poles:	6	Nominal Efficiency:	91 %
Output Power:	10HP 7.4KW	Guaranteed Efficiency:	90.2
RPM:	1175	3/4 Load Efficiency:	91.7
Voltage:	575	KVA Code:	H
Hertz:	60	Max KVAR:	4.6
Amps - FL:	10.6	Power Factor:	77.5
Service Factor:	1.15	Bearing - DE:	6309ZC3
Alt Service Factor:	--	Bearing - ODE:	6309ZC3

Enclosure is Totally Enclosed Fan-Cooled

Stamped Nameplate Notes:

IEEE-STD-841-2009
 DE BRG 45BC03JP30 ODE BRG 45BC03JP30
 STAMP NP249A5564P051 AS BELOW:
 MODEL:5KS256XAA304D2 S/N: XXX
 CSA CERTIFIED CSA09.2216219 FOR EX NA IIC 200C GC
 CL 1 ZONE2 AEX NA IIC 200C;CL 1 DIV2 GRP ABCD 200C
 IN -25C <= AMB <= 40C, 1.0 SF ON SINE-WAVE PWR
 SURF TEMP 200C AT 1.15SF ON SINE-WAVE PWR
 OR 200 C VT OR 200 C CT OR 200 C CHP PWM CONTROL
 ALTERNATE RATING FOR PWM CONTROL 1.0SF 40C AMB
 VT 0-60 HZ, CT 3-60 HZ, CHP 60-90 HZ.

Additional Information:

6P - T EXTN
 STANDARD FLOOR MOUNT
 C/BOX 137 CU IN-1.25 NPT
 F1 CONDUIT BOX MOUNTING
 PAINTED FRAME ID & SHAFT,
 FAN COVER INSIDE & ODE E/S OUTSIDE
 ROUTINE AND 5 POINT VIBRATION TESTS INCL IN C/BOX
 INPRO SEAL BOTH ENDS
 GROUND SCREW ON FRAME
 SHAFT RUNOUT LIMIT .001" TIR
 COPPER WASHER UNDER HEADS OF BEARING CAP BOLTS
 APPLY TITE-SEAL (A50CD427A) ON BEARING CAP SCREWS, RABBETS,
 AND PLUG THREADS
 OIL RESISTANT SLEEVING ON LEADS

Performance Characteristics

1st Winding 1st Connection

Design: 25BD3060B

Marks:

LOAD %	125.0	115.0	100.0	75.0	50.0	25.0	0.0
% EFF	90.39	90.81	91.52	91.72	91.05	86.77	0.00
% PF	80.81	79.83	77.7	71.53	59.74	38.13	4.76
AMPS	12.81	11.88	10.53	8.56	6.88	5.66	5.09

TORQ(FL)#FT	44.67	TORQ(LR)%FL	213.53	TORQ(BD)%FL	295.83
AMPS(LR)	68.9	PF AT START	0.4		

This motor is capable of two cold or one hot start with a maximum connected load inertia of 1023 Lb-Ft Sq (43.07 Kg-meter Sq)at 100% voltage, where the load torque varies with the square of the speed. Acceleration time with maximum inertia and the above load type is 45 seconds. Safe stall time at 100% voltage is 101 seconds cold, 69 seconds hot. Rotor inertia is 2.01 Lb-Ft Sq (0.08 Kg-meter Sq).

Open Circuit A-C:	0.246	Short Circuit D-C:	0.012
Short Circuit A-C:	0.016	X/R Ratio:	4.337
Stator Slots:	54	Rotor Slots:	42

Speed Torque Current Curve (First Connection, First Speed)

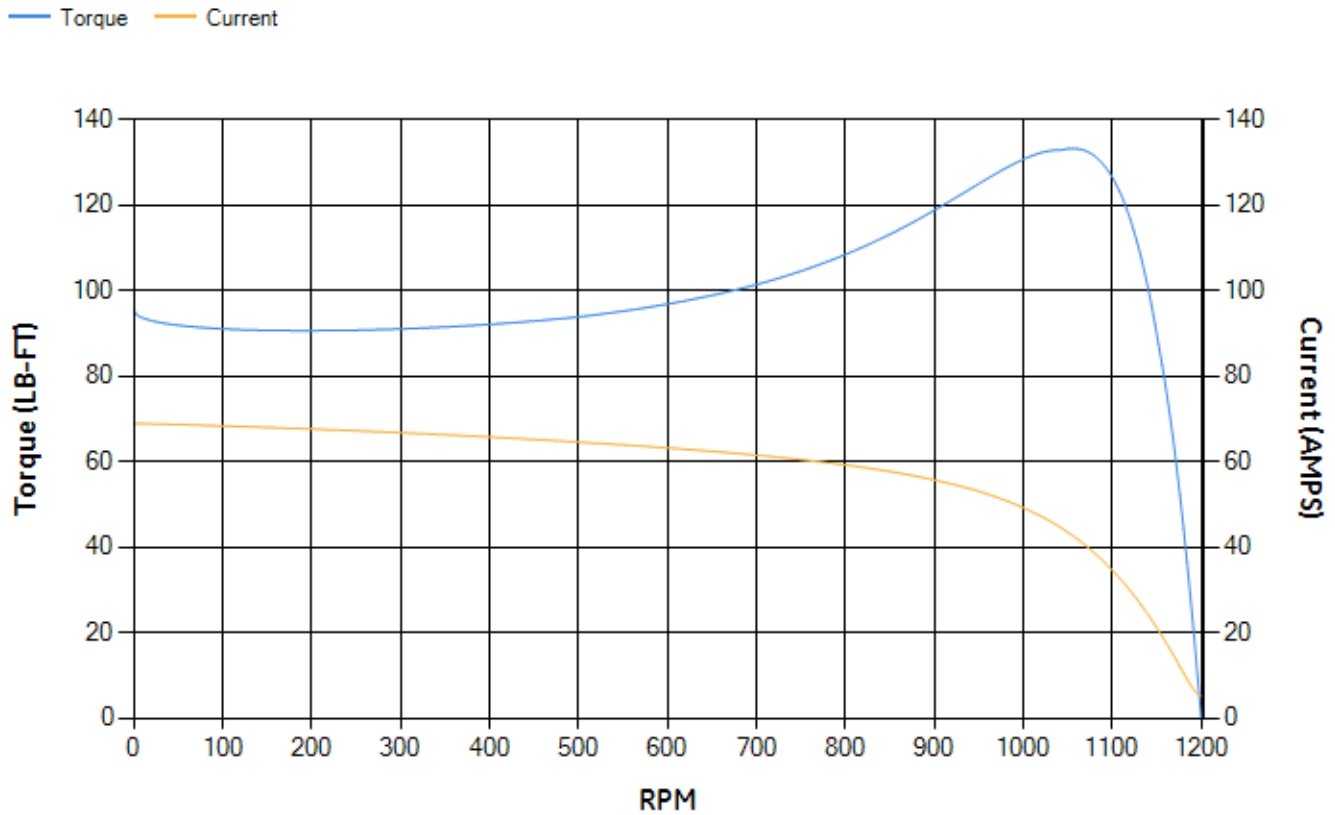

Marks:

NOTE 1: CONDUIT BOX MAY BE ASSEMBLED WITH ENTRANCE UP, DOWN OR TO EITHER SIDE.
 NOTE 2: F1 ASSEMBLY AS SHOWN. F2 ASSEMBLY CONDUIT BOX ON OPPOSITE SIDE FROM SHOWN LOCATION.
 NOTE 3: SHAFT RUNOUT WILL NOT EXCEED .001" I. P.R.

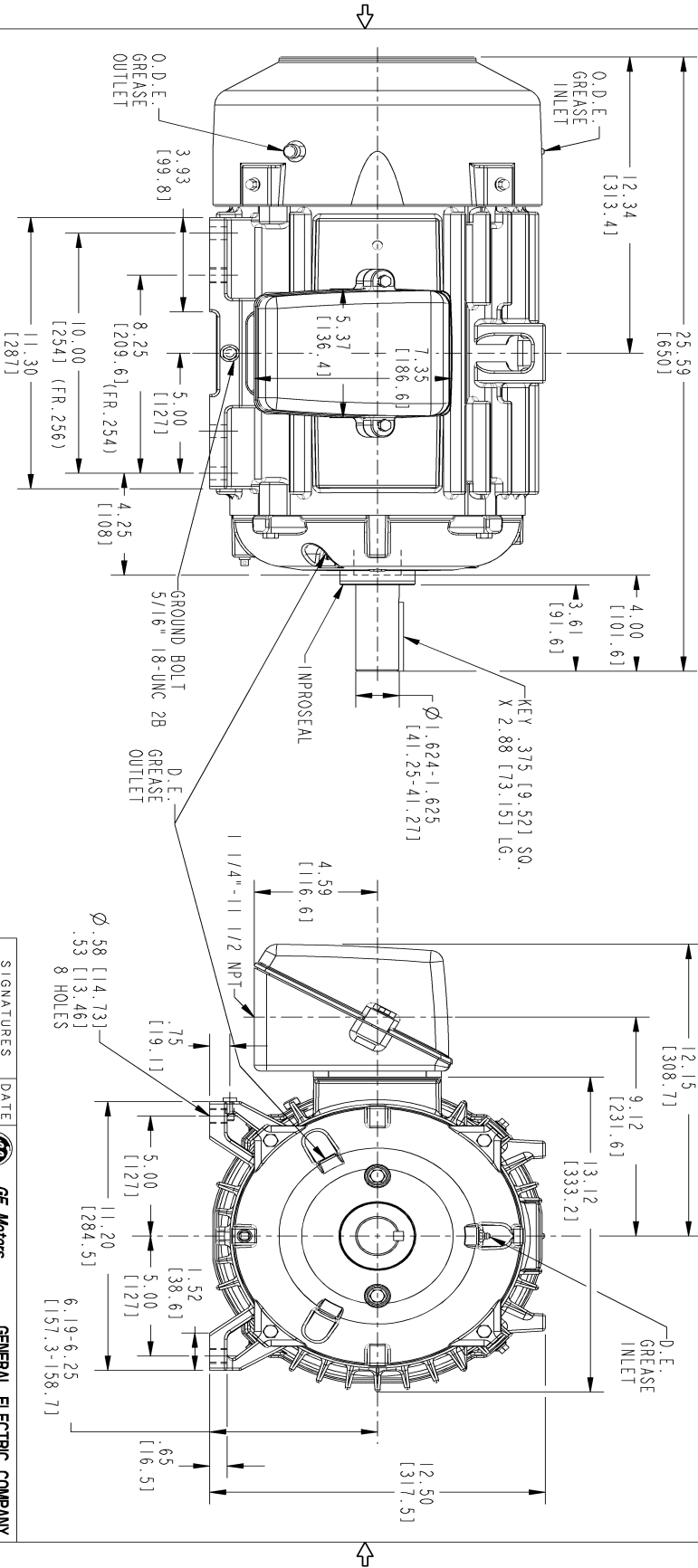

SIZE	DRAWING NO.	REV	SHEET
B	4002B5825PAP5311	0	1

REV.	DESCRIPTION	DATE	APPROVED

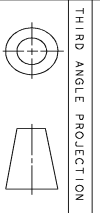

THIRD ANGLE PROJECTION

SIGNATURES		DATE	
MODEL	TEJASNI	05/18/15	
DETAIL	TEJASNI	05/18/15	
CHECKED	KARTHICK	05/18/15	
ENGR	SHAMANTHI	05/18/15	
QC			
ISSUED	TEJASNI	05/18/15	
SOLID MODEL: 4002B5825PAP5311			

GE Motors
 GENERAL ELECTRIC COMPANY

TITLE
INDUCTION MOTOR OUTLINE
 STANDARD CONSTRUCTION FOR IEEE-841 SPEC.
 FMR: FR250T TFC XSD ULTRA

SIZE DRAWING: **4002B5825PAP5311**
 SCALE: 0.250 REF. No.: 4002B5825PAP5311

REV: **0**
 SHEET 1 OF 1

Marks:

Connection Diagram
GEM2034E-FIG1



End shield Assembly		
Part Description	DE Side Part#	ODE Side Part#
End Shield	4004D5283PB1	4004D5283SE1
Bearing	235A2607AA01	235A2607AA01
Slinger/Inproseal	4002B5914AF4	4002B5914AG4

Fan & Fan Cover Assembly	
Part Description	Part#
Fan	159C6800G01
Fan Cover	4003C5788PA1

Conduit & Accessories Box Assembly	
Part Description	Part#
Conduit Box	4002B5728PA-G04

Mechanical Accessories	
Part Description	Part#
Brake	
Tachometer	