

# Product Information Packet

November 8, 2016

Data shown is for the current revision model #. Ensure your nameplate model # matches.

<b>Model Number:</b>	<b>5KS215XAA404D3</b>
<b>Catalog Number:</b>	<b>M9491</b>
<b>Instruction Manual:</b>	GEI-56128
<b>Connection Diagram:</b>	GEM2034E-FIG1
<b>Outline Drawing:</b>	4002B5821PAP5311

Accessory Connection Diagrams			
<b>Bearing Thermocouple:</b>	None	<b>Heater:</b>	None
<b>RTD:</b>	None	<b>Thermistor:</b>	None
<b>Thermostat:</b>	None	<b>Winding Thermocouple:</b>	None
<b>Bearing RTD:</b>	None		

## Table of Contents

Specification	01
Performance Characteristics	02
Outline Drawing	03
Connection Drawing(s)	04
Spare parts	05



**Marks:**

<b>MODEL NUMBER:</b>	<b>5KS215XAA404D3</b>	<b>Estimated Weight:</b>	220 Lbs
<b>Outline Drawing:</b>	4002B5821PAP5311	<b>Time Rating:</b>	CONT
<b>Connection Diagram:</b>	GEM2034E-FIG1	<b>Enclosure:</b>	TEFC
<b>Instruction Book:</b>	GEI-56128	<b>Encl Construction:</b>	841
<b>Design Code:</b>	21BD4023BB	<b>Ambient Max(°C):</b>	40
<b>Type:</b>	KS	<b>Alt Ambient Max(°C):</b>	--
<b>Frame:</b>	215T	<b>Insulation Class:</b>	H
<b>Phases:</b>	3	<b>NEMA Design:</b>	B
<b>Poles:</b>	8	<b>Nominal Efficiency:</b>	85.5 %
<b>Output Power:</b>	3HP 2.2KW	<b>Guaranteed Efficiency:</b>	84.0
<b>RPM:</b>	875	<b>3/4 Load Efficiency:</b>	86.4
<b>Voltage:</b>	575	<b>KVA Code:</b>	K
<b>Hertz:</b>	60	<b>Max KVAR:</b>	2.7
<b>Amps - FL:</b>	4.4	<b>Power Factor:</b>	59.5
<b>Service Factor:</b>	1.15	<b>Bearing - DE:</b>	6208ZC3
<b>Alt Service Factor:</b>	--	<b>Bearing - ODE:</b>	6208ZC3

**Enclosure is Totally Enclosed Fan-Cooled**

**Stamped Nameplate Notes:**

IEEE-STD-841-2009  
 DE BRG 40BC02JP30 ODE BRG 40BC02JP30  
 STAMP NP249A5564P051 AS BELOW:  
 MODEL:5KS215XAA404D3 S/N: XXX  
 CSA CERTIFIED CSA09.2216219 FOR EX NA IIC 200C GC  
 CL 1 ZONE2 AEX NA IIC 200C;CL 1 DIV2 GRP ABCD 200C  
 IN -25C <= AMB <= 40C, 1.0 SF ON SINE-WAVE PWR  
 SURF TEMP 200C AT 1.15SF ON SINE-WAVE PWR  
 OR 200 C VT OR 200 C CT OR 200 C CHP PWM CONTROL  
 ALTERNATE RATING FOR PWM CONTROL 1.0SF 40C AMB  
 VT 0-60 HZ, CT 3-60 HZ, CHP 60-90 HZ.

**Additional Information:**

8P - T EXTN  
 STANDARD FLOOR MOUNT  
 C/BOX 55 CU IN-1.00 NPT  
 F1 CONDUIT BOX MOUNTING  
 PAINTED FRAME ID & SHAFT,  
 FAN COVER INSIDE & ODE E/S OUTSIDE  
 ROUTINE AND 5 POINT VIBRATION TESTS INCL IN C/BOX  
 INPRO SEAL BOTH ENDS  
 GROUND SCREW ON FRAME  
 SHAFT RUNOUT LIMIT .001" TIR  
 COPPER WASHER UNDER HEADS OF BEARING CAP BOLTS  
 APPLY TITE-SEAL (A50CD427A) ON BEARING CAP SCREWS, RABBETS,  
 AND PLUG THREADS  
 OIL RESISTANT SLEEVING ON LEADS



**Performance Characteristics**

1st Winding 1st Connection

**Design: 21BD4023BB**

**Marks:**

LOAD %	125.0	115.0	100.0	75.0	50.0	25.0	0.0
% EFF	85.52	86.01	86.67	86.37	84.3	76.15	0.00
% PF	64.48	62.7	59.27	51.16	39.48	24.01	5.4
AMPS	5.09	4.79	4.4	3.81	3.37	3.07	2.96

<b>TORQ(FL)#FT</b>	18.02	<b>TORQ(LR)%FL</b>	188.74	<b>TORQ(BD)%FL</b>	321.63
<b>AMPS(LR)</b>	23.88	<b>PF AT START</b>	0.35		

This motor is capable of two cold or one hot start with a maximum connected load inertia of 728 Lb-Ft Sq (30.65 Kg-meter Sq)at 100% voltage, where the load torque varies with the square of the speed. Acceleration time with maximum inertia and the above load type is 59 seconds. Safe stall time at 100% voltage is 132 seconds cold, 94 seconds hot. Rotor inertia is 0.82 Lb-Ft Sq (0.03 Kg-meter Sq).

<b>Open Circuit A-C:</b>	0.113	<b>Short Circuit D-C:</b>	0.012
<b>Short Circuit A-C:</b>	0.015	<b>X/R Ratio:</b>	4.507
<b>Stator Slots:</b>	36	<b>Rotor Slots:</b>	48

**Speed Torque Current Curve (First Connection, First Speed)**

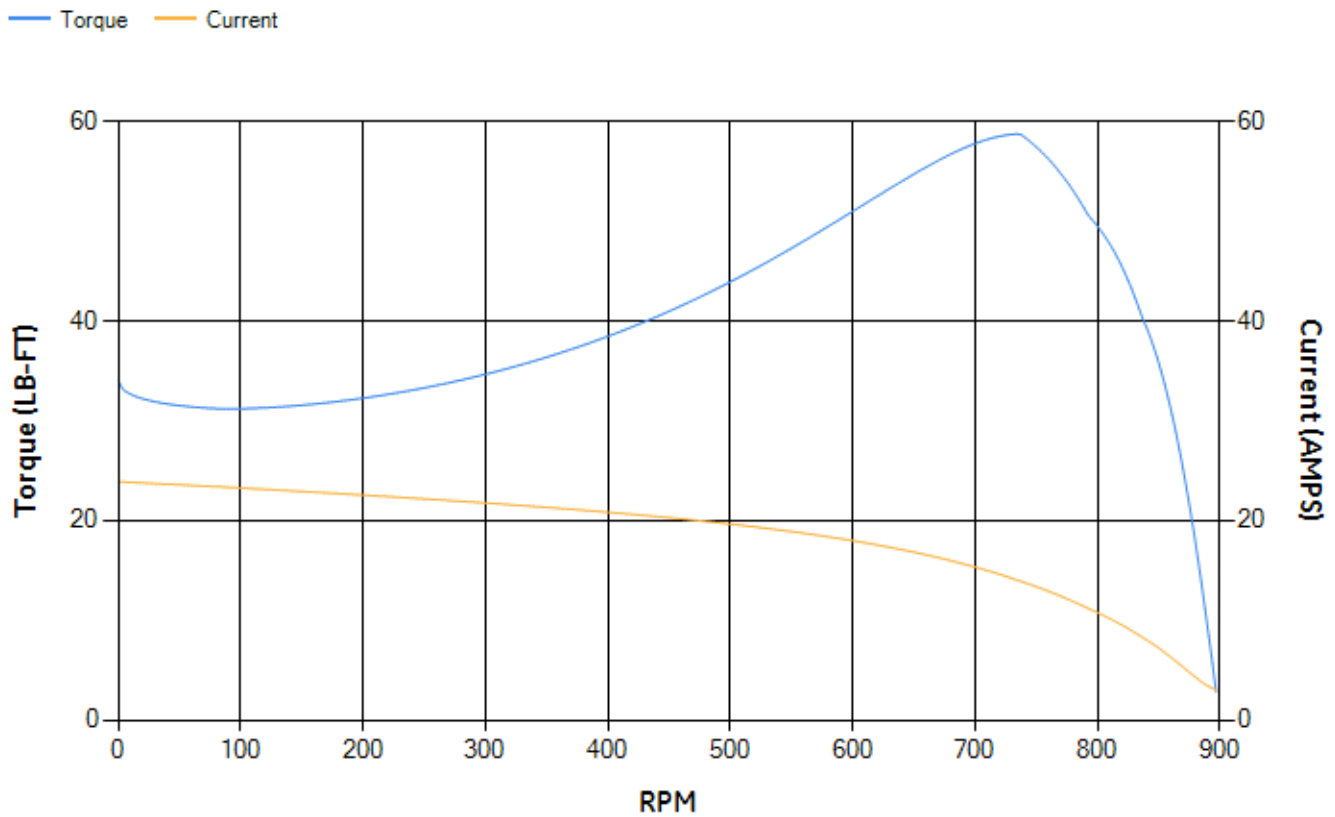

Marks:

NOTE 1: CONDUIT BOX MAY BE ASSEMBLED WITH ENTRANCE UP OR DOWN OR TO EITHER SIDE.  
 NOTE 2: F1 ASSEMBLY AS SHOWN. F2 ASSEMBLY CONDUIT BOX ON OPPOSITE SIDE FROM SHOWN LOCATION.  
 NOTE 3: SHAFT RUNOUT WILL NOT EXCEED .001 T.I.R.  
 NOTE 4: ALL DIMENSIONS ARE IN INCHES, BRACKETED DIMENSIONS ARE IN METRIC (MILLIMETERS).

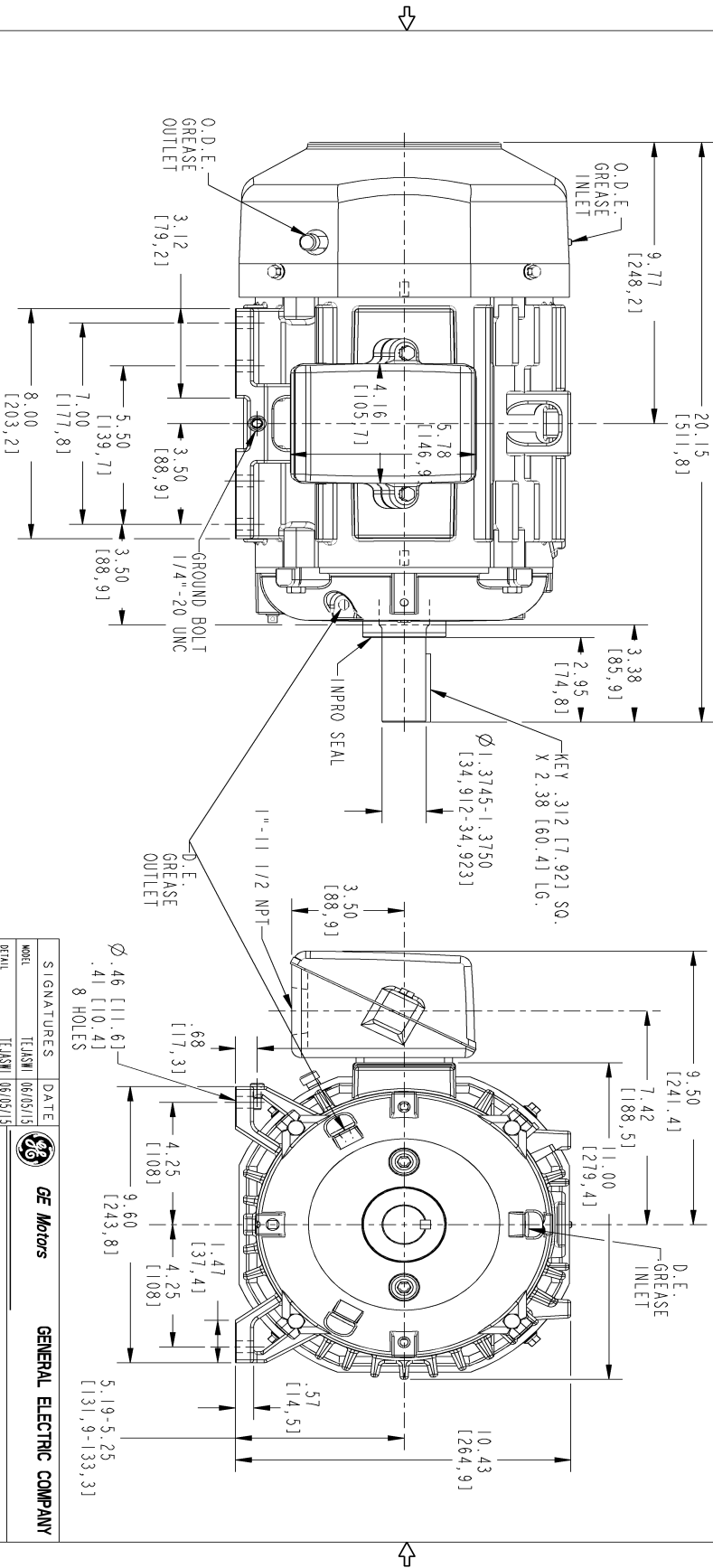

SIZE	DRAWING NO.	REV	SHEET
B	4002B5821PAP5311	0	1
REVISIONS			
REV.	DESCRIPTION	DATE	APPROVED

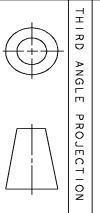

SIGNATURES	DATE	<p><b>GE Motors</b> GENERAL ELECTRIC COMPANY</p>
MODEL	TEJASVI [06/05/15]	
DETAIL	TEJASVI [06/05/15]	
DESIGN	VENKAT [06/05/15]	
ENG'G	VENKAT [06/05/15]	
QUALITY	TEJASVI [06/05/15]	
ISSUED	TEJASVI [06/05/15]	SCALE: 0.300 REF. No.: 4002B5821PAP5301
TITLE		STANDARD CONSTRUCTION FOR IEEE-841 SPEC FNM: FR218/215 T TERC
INDUCTION MOTOR OUTLINE		
4002B5821PAP5311		
REV	0	SHEET 1 of 1

Marks:

**Connection Diagram**  
**GEM2034E-FIG1**



End shield Assembly		
Part Description	DE Side Part#	ODE Side Part#
End Shield	4004D5282PB1	4004D5282SJ1
Bearing	235A2603AA01	235A2603AA01
Slinger/Inproseal	4002B5914AF3	4002B5914AG3

Fan & Fan Cover Assembly	
Part Description	Part#
Fan	159C6700G01
Fan Cover	4003C5787PA1

Conduit & Accessories Box Assembly	
Part Description	Part#
Conduit Box	4002B5721PA-G01

Mechanical Accessories	
Part Description	Part#
Brake	
Tachometer	